

## KR AGILUS sixx

With W and C Variants  
Operating Instructions

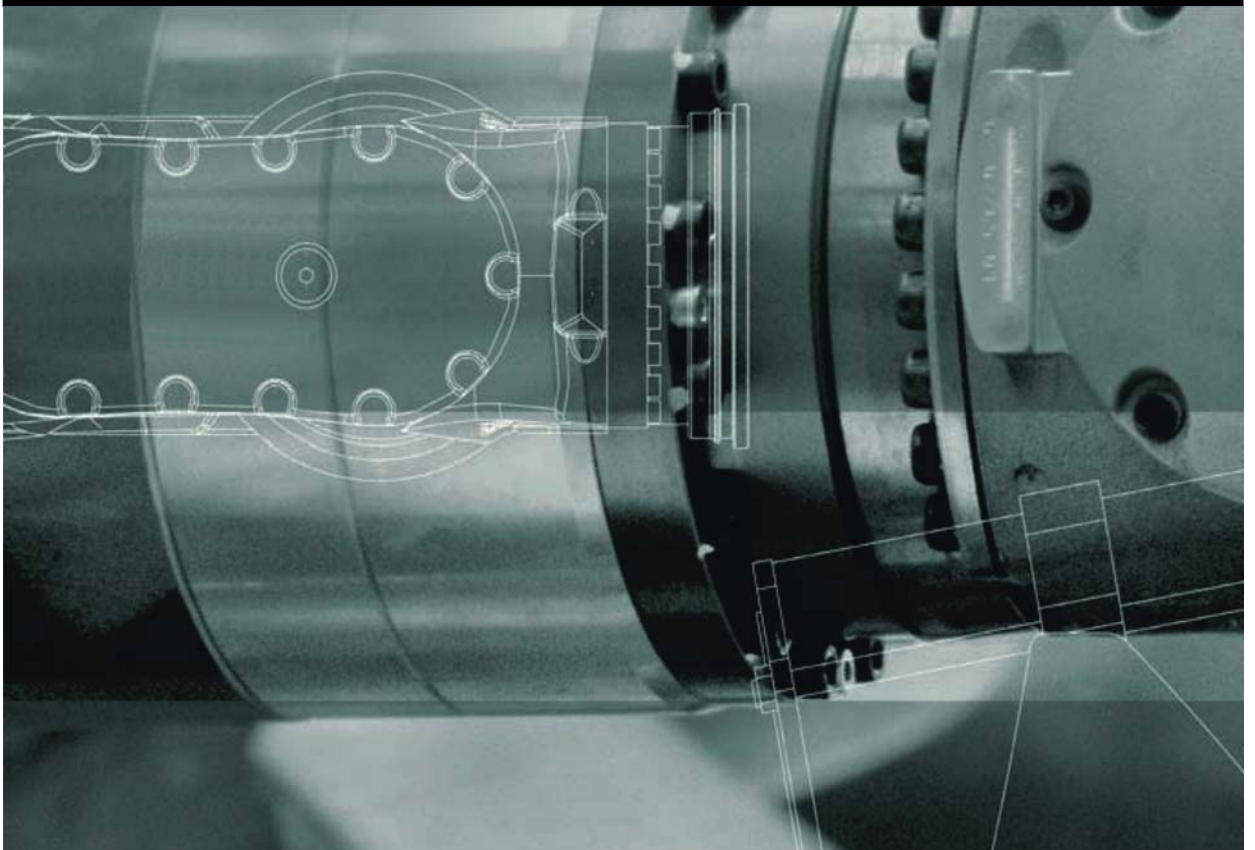

Issued: 25.03.2015

Version: BA KR AGILUS sixx V12



© Copyright 2015

KUKA Roboter GmbH  
Zugspitzstraße 140  
D-86165 Augsburg  
Germany

This documentation or excerpts therefrom may not be reproduced or disclosed to third parties without the express permission of KUKA Roboter GmbH.

Other functions not described in this documentation may be operable in the controller. The user has no claims to these functions, however, in the case of a replacement or service work.

We have checked the content of this documentation for conformity with the hardware and software described. Nevertheless, discrepancies cannot be precluded, for which reason we are not able to guarantee total conformity. The information in this documentation is checked on a regular basis, however, and necessary corrections will be incorporated in the subsequent edition.

Subject to technical alterations without an effect on the function.

Translation of the original documentation

KIM-PS5-DOC

Publication:	Pub BA KR AGILUS sixx (PDF) en
Book structure:	BA KR AGILUS sixx V11.2
Version:	BA KR AGILUS sixx V12

# Contents

<b>1</b>	<b>Introduction</b>	<b>7</b>
1.1	Industrial robot documentation	7
1.2	Representation of warnings and notes	7
1.3	Terms used	7
<b>2</b>	<b>Purpose</b>	<b>9</b>
2.1	Target group	9
2.2	Intended use	9
<b>3</b>	<b>Product description</b>	<b>11</b>
3.1	Overview of the robot system	11
3.2	Description of the manipulator	12
<b>4</b>	<b>Technical data</b>	<b>15</b>
4.1	Basic data, KR 6 sixx	16
4.2	Axis data, KR 6 sixx	18
4.3	Payloads, KR 6 sixx	26
4.4	Foundation data, KR 6 sixx	31
4.5	Basic data, KR 10 sixx	33
4.6	Axis data, KR 10 sixx	35
4.7	Payloads, KR 10 sixx	43
4.8	Foundation data, KR 10 sixx	49
4.9	Plates and labels	51
4.10	Stopping distances and times	52
4.10.1	General information	52
4.10.2	Terms used	53
4.10.3	Stopping distances and times, KR 6 R700 sixx and KR 6 R700 sixx C	54
4.10.3.1	Stopping distances and stopping times for STOP 0, axis 1 to axis 3	54
4.10.3.2	Stopping distances and stopping times for STOP 1, axis 1	55
4.10.3.3	Stopping distances and stopping times for STOP 1, axis 2	57
4.10.3.4	Stopping distances and stopping times for STOP 1, axis 3	59
4.10.4	Stopping distances and times, KR 6 R700 sixx W	59
4.10.4.1	Stopping distances and stopping times for STOP 0, axis 1 to axis 3	59
4.10.4.2	Stopping distances and stopping times for STOP 1, axis 1	61
4.10.4.3	Stopping distances and stopping times for STOP 1, axis 2	63
4.10.4.4	Stopping distances and stopping times for STOP 1, axis 2	65
4.10.5	Stopping distances and times, KR 6 R900 sixx and KR 6 R900 sixx C	65
4.10.5.1	Stopping distances and stopping times for STOP 0, axis 1 to axis 3	65
4.10.5.2	Stopping distances and stopping times for STOP 1, axis 1	67
4.10.5.3	Stopping distances and stopping times for STOP 1, axis 2	69
4.10.5.4	Stopping distances and stopping times for STOP 1, axis 3	71
4.10.6	Stopping distances and times, KR 6 R900 sixx W	71
4.10.6.1	Stopping distances and stopping times for STOP 0, axis 1 to axis 3	71
4.10.6.2	Stopping distances and stopping times for STOP 1, axis 1	73
4.10.6.3	Stopping distances and stopping times for STOP 1, axis 2	75
4.10.6.4	Stopping distances and stopping times for STOP 1, axis 3	77
4.10.7	Stopping distances and times, KR 10 R900 sixx and KR 10 R1100 sixx	77
4.10.7.1	Stopping distances and stopping times for STOP 0, axis 1 to axis 3	77

4.10.7.2	Stopping distances and stopping times for STOP 1, axis 1 .....	79
4.10.7.3	Stopping distances and stopping times for STOP 1, axis 2 .....	81
4.10.7.4	Stopping distances and stopping times for STOP 1, axis 3 .....	83
4.10.8	Stopping distances and times, KR 10 R900 sixx W and KR 10 R1100 sixx W ....	83
4.10.8.1	Stopping distances and stopping times for STOP 0, axis 1 to axis 3 .....	83
4.10.8.2	Stopping distances and stopping times for STOP 1, axis 1 .....	85
4.10.8.3	Stopping distances and stopping times for STOP 1, axis 2 .....	87
4.10.8.4	Stopping distances and stopping times for STOP 1, axis 3 .....	89
<b>5</b>	<b>Safety</b> .....	<b>91</b>
5.1	General .....	91
5.1.1	Liability .....	91
5.1.2	Intended use of the industrial robot .....	92
5.1.3	EC declaration of conformity and declaration of incorporation .....	92
5.1.4	Terms used .....	93
5.2	Personnel .....	93
5.3	Workspace, safety zone and danger zone .....	94
5.4	Overview of protective equipment .....	95
5.4.1	Mechanical end stops .....	95
5.4.2	Mechanical axis range limitation (optional) .....	95
5.4.3	Axis range monitoring (optional) .....	95
5.4.4	Options for moving the manipulator without drive energy .....	96
5.4.5	Labeling on the industrial robot .....	96
5.5	Safety measures .....	97
5.5.1	General safety measures .....	97
5.5.2	Transportation .....	98
5.5.3	Start-up and recommissioning .....	98
5.5.4	Manual mode .....	99
5.5.5	Automatic mode .....	100
5.5.6	Maintenance and repair .....	100
5.5.7	Decommissioning, storage and disposal .....	102
5.6	Applied norms and regulations .....	102
<b>6</b>	<b>Planning</b> .....	<b>105</b>
6.1	Information for planning .....	105
6.2	Mounting base .....	105
6.3	Machine frame mounting .....	107
6.4	Connecting cables and interfaces .....	109
6.5	Customer interfaces .....	110
<b>7</b>	<b>Transportation</b> .....	<b>117</b>
7.1	Transporting the manipulator .....	117
<b>8</b>	<b>Start-up and recommissioning</b> .....	<b>123</b>
8.1	Installing the mounting base .....	123
8.2	Installing the machine frame mounting assembly .....	124
8.3	Installing a floor-mounted robot .....	125
8.4	Installing a wall-mounted robot .....	126
8.5	Installing a ceiling-mounted robot .....	130
8.6	Description of the connecting cables .....	134



8.7	Moving the manipulator without drive energy .....	140
<b>9</b>	<b>Maintenance</b> .....	<b>141</b>
9.1	Maintenance symbols .....	141
9.2	Maintenance table .....	141
9.3	Greasing the inside of covers A2 and A3 .....	143
9.4	Removing and installing toothed belts A5 and A6 .....	144
9.5	Cleaning the robot .....	145
<b>10</b>	<b>Repair</b> .....	<b>147</b>
10.1	Measuring and adjusting the toothed belt tension for the in-line wrist, A5, A6 .....	147
<b>11</b>	<b>Decommissioning, storage and disposal</b> .....	<b>151</b>
11.1	Decommissioning, floor-mounted robot .....	151
11.2	Decommissioning, wall-mounted robot .....	152
11.3	Decommissioning, ceiling-mounted robot .....	155
11.4	Storage .....	158
11.5	Disposal .....	159
<b>12</b>	<b>Appendix</b> .....	<b>161</b>
12.1	Tightening torques .....	161
12.2	Safety data sheets .....	161
12.2.1	Safety data sheet for Flexolub®-A1 lubricant .....	161
12.2.2	Safety data sheet for OBEEN FS 2 lubricant .....	165
<b>13</b>	<b>KUKA Service</b> .....	<b>183</b>
13.1	Requesting support .....	183
13.2	KUKA Customer Support .....	183
	<b>Index</b> .....	<b>191</b>



# 1 Introduction

## 1.1 Industrial robot documentation

The industrial robot documentation consists of the following parts:

- Documentation for the manipulator
- Documentation for the robot controller
- Operating and programming instructions for the System Software
- Instructions for options and accessories
- Parts catalog on storage medium

Each of these sets of instructions is a separate document.

## 1.2 Representation of warnings and notes

### Safety

These warnings are relevant to safety and **must** be observed.

 <b>DANGER</b>	These warnings mean that it is certain or highly probable that death or severe injuries <b>will</b> occur, if no precautions are taken.
---	---

 <b>WARNING</b>	These warnings mean that death or severe injuries <b>may</b> occur, if no precautions are taken.
--	--

 <b>CAUTION</b>	These warnings mean that minor injuries <b>may</b> occur, if no precautions are taken.
--	--

<b>NOTICE</b>	These warnings mean that damage to property <b>may</b> occur, if no precautions are taken.
---------------	--

	These warnings contain references to safety-relevant information or general safety measures. These warnings do not refer to individual hazards or individual precautionary measures.
---	---

This warning draws attention to procedures which serve to prevent or remedy emergencies or malfunctions:

<b>SAFETY INSTRUCTIONS</b>	Procedures marked with this warning <b>must</b> be followed exactly.
----------------------------	--

### Hints

These notices serve to make your work easier or contain references to further information.

	Tip to make your work easier or reference to further information.
---	---

## 1.3 Terms used

Term	Description
MEMD	Micro Electronic Mastering Device
KL	KUKA linear unit

Term	Description
RDC	Resolver Digital Converter
smartPAD	The smartPAD teach pendant has all the operator control and display functions required for operating and programming the industrial robot.

## 2 Purpose

### 2.1 Target group

This documentation is aimed at users with the following knowledge and skills:

- Advanced knowledge of mechanical engineering
- Advanced knowledge of electrical and electronic systems
- Knowledge of the robot controller system



For optimal use of our products, we recommend that our customers take part in a course of training at KUKA College. Information about the training program can be found at [www.kuka.com](http://www.kuka.com) or can be obtained directly from our subsidiaries.

### 2.2 Intended use

**Use** The industrial robot is intended for handling tools and fixtures, or for processing or transferring components or products. Use is only permitted under the specified environmental conditions.

**Misuse** Any use or application deviating from the intended use is deemed to be misuse and is not allowed. This includes e.g.:

- Transportation of persons and animals
- Use as a climbing aid
- Operation outside the permissible operating parameters
- Use in potentially explosive environments
- Use in underground mining

#### **NOTICE**

Changing the structure of the manipulator, e.g. by drilling holes, etc., can result in damage to the components. This is considered improper use and leads to loss of guarantee and liability entitlements.

#### **NOTICE**

Deviations from the operating conditions specified in the technical data or the use of special functions or applications can lead to premature wear. KUKA Roboter GmbH must be consulted.



The robot system is an integral part of a complete system and may only be operated in a CE-compliant system.



## 3 Product description

### 3.1 Overview of the robot system

A robot system (>>> Fig. 3-1 ) comprises all the assemblies of an industrial robot, including the manipulator (mechanical system and electrical installations), control cabinet, connecting cables, end effector (tool) and other equipment. The KR AGILUS sixx product family consists of the following types:

- KR 6 R700 sixx
- KR 6 R900 sixx
- KR 10 R900 sixx
- KR 10 R1100 sixx

The robots are also available as W and C variants (wall-mounted and ceiling-mounted versions).

An industrial robot of this type comprises the following components:

- Manipulator
- Robot controller
- smartPAD teach pendant
- Connecting cables
- Software
- Options, accessories

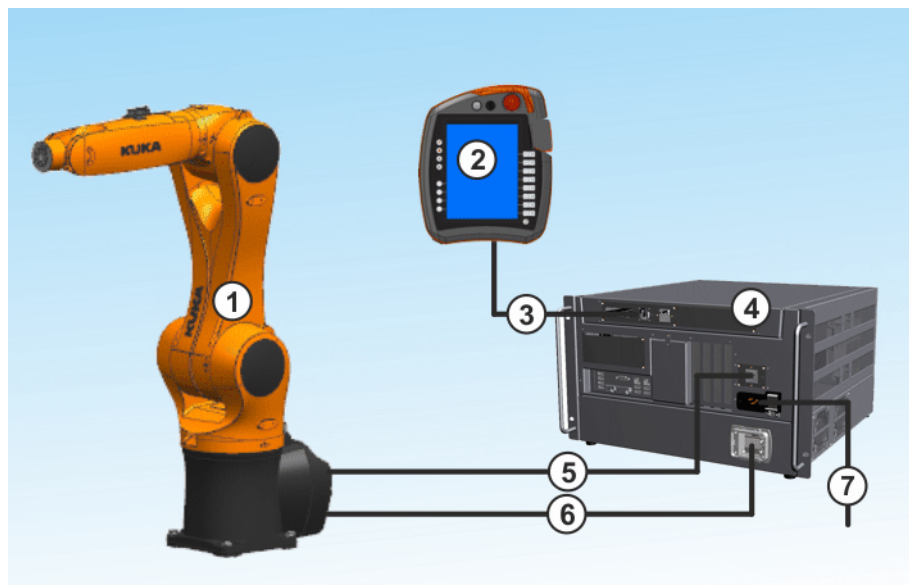

**Fig. 3-1: Example of an industrial robot**

- 1 Manipulator
- 2 smartPAD teach pendant
- 3 Connecting cable, smartPAD
- 4 Robot controller
- 5 Connecting cable, data cable
- 6 Connecting cable, motor cable



## 3.2 Description of the manipulator

### Overview

The manipulators are 6-axis jointed-arm manipulators made of cast light alloy. Each axis is fitted with a brake. All motor units and current-carrying cables are protected against dirt and moisture beneath screwed-on cover plates.

The robot consists of the following principal components:

- In-line wrist
- Arm
- Link arm
- Rotating column
- Base frame
- Electrical installations

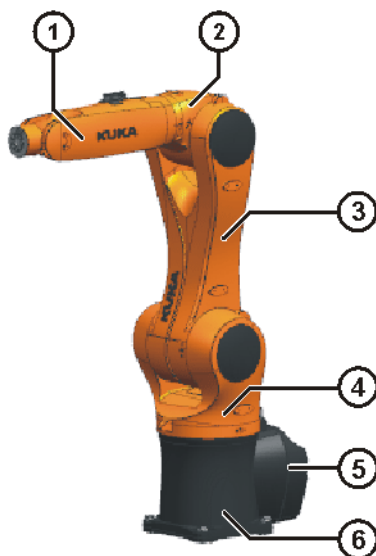

**Fig. 3-2: Principal components**

- |   |               |   |                          |
|---|---------------|---|--------------------------|
| 1 | In-line wrist | 4 | Rotating column          |
| 2 | Arm           | 5 | Electrical installations |
| 3 | Link arm      | 6 | Base frame               |

### In-line wrist A4, A5, A6

The robot is fitted with a 3-axis in-line wrist. The in-line wrist consists of axes 4, 5 and 6.

There are three 5/2-way solenoid valves and a CAT5 data cable in the in-line wrist that can be used for controlling tools.

The in-line wrist also accommodates the 10-contact circular connector of the wrist I/O cable and interface A4 for the energy supply system.

### Arm A3

The arm is the link between the in-line wrist and the link arm. The arm is driven by the motor of axis 3.

### Link arm A2

The link arm is the assembly located between the arm and the rotating column. It houses the motor and gear unit of axis 2. The supply lines of the energy supply system and the cable set for axes 2 to 6 are routed through the link arm.

### Rotating column A1

The rotating column houses the motors of axes 1 and 2. The rotational motion of axis 1 is performed by the rotating column. This is screwed to the base frame via the gear unit of axis 1 and is driven by a motor in the rotating column. The link arm is also mounted in the rotating column.

<b>Base frame</b>	The base frame is the base of the robot. Interface A1 is located at the rear of the base frame. It constitutes the interface for the connecting cables between the robot, the controller and the energy supply system.
<b>Electrical installations</b>	The electrical installations include all the motor and control cables for the motors of axes 1 to 6. All connections are pluggable. The electrical installations also include the RDC box, which is integrated into the robot. The connectors for the motor and data cables are mounted on the robot base frame. The connecting cables from the robot controller are connected here by means of connectors. The electrical installations also include a protective circuit.
<b>Options</b>	The robot can be fitted and operated with various options, e.g. working range limitation A1 or brake release device. The option is described in separate documentation.



## 4 Technical data

The technical data for the individual robot types can be found in the following sections:

Robot	Technical data
KR 6 sixx	
KR 6 R700 sixx <ul style="list-style-type: none"> <li>■ KR 6 R700 sixx</li> <li>■ KR 6 R700 sixx W</li> <li>■ KR 6 R700 sixx C</li> </ul> KR 6 R900 sixx <ul style="list-style-type: none"> <li>■ KR 6 R900 sixx</li> <li>■ KR 6 R900 sixx W</li> <li>■ KR 6 R900 sixx C</li> </ul>	Basic data (>>> 4.1 "Basic data, KR 6 sixx" Page 16)
	Axis data (>>> 4.2 "Axis data, KR 6 sixx" Page 18)
	Payloads (>>> 4.3 "Payloads, KR 6 sixx" Page 26)
	Foundation data (>>> 4.4 "Foundation data, KR 6 sixx" Page 31)
	Plates and labels (>>> 4.9 "Plates and labels" Page 51)
	Stopping distances <ul style="list-style-type: none"> <li>■ KR 6 R700 sixx and KR 6 R700 sixx C (&gt;&gt;&gt; 4.10.3 "Stopping distances and times, KR 6 R700 sixx and KR 6 R700 sixx C" Page 54)</li> <li>■ KR 6 R700 sixx W (&gt;&gt;&gt; 4.10.4 "Stopping distances and times, KR 6 R700 sixx W" Page 59)</li> <li>■ KR 6 R900 sixx and KR 6 R900 sixx C (&gt;&gt;&gt; 4.10.5 "Stopping distances and times, KR 6 R900 sixx and KR 6 R900 sixx C" Page 65)</li> <li>■ KR 6 R900 sixx W (&gt;&gt;&gt; 4.10.6 "Stopping distances and times, KR 6 R900 sixx W" Page 71)</li> </ul>
Robot	Technical data
KR 10 sixx	

Robot	Technical data
KR 10 R900 sixx ■ KR 10 R900 sixx ■ KR 10 R900 sixx W ■ KR 10 R900 sixx C KR 10 R1100 sixx ■ KR 10 R1100 sixx ■ KR 10 R1100 sixx W ■ KR 10 R1100 sixx C	Basic data (>>> 4.5 "Basic data, KR 10 sixx" Page 33)
	Axis data (>>> 4.6 "Axis data, KR 10 sixx" Page 35)
	Payloads (>>> 4.7 "Payloads, KR 10 sixx" Page 43)
	Foundation data (>>> 4.8 "Foundation data, KR 10 sixx" Page 49)
	Plates and labels (>>> 4.9 "Plates and labels" Page 51)
	Stopping distances <ul style="list-style-type: none"> <li>■ KR 10 R900 sixx and KR 10 R900 sixx C                              (&gt;&gt;&gt; 4.10.7 "Stopping distances and times, KR 10 R900 sixx and KR 10 R1100 sixx" Page 77)</li> <li>■ KR 10 R900 sixx W                              (&gt;&gt;&gt; 4.10.8 "Stopping distances and times, KR 10 R900 sixx W and KR 10 R1100 sixx W" Page 83)</li> <li>■ KR 10 R1100 sixx and KR 10 R1100 sixx C                              (&gt;&gt;&gt; 4.10.7 "Stopping distances and times, KR 10 R900 sixx and KR 10 R1100 sixx" Page 77)</li> <li>■ KR 10 R1100 sixx W                              (&gt;&gt;&gt; 4.10.8 "Stopping distances and times, KR 10 R900 sixx W and KR 10 R1100 sixx W" Page 83)</li> </ul>

#### 4.1 Basic data, KR 6 sixx

##### Basic data

Type	KR 6 R700 sixx KR 6 R700 sixx W KR 6 R700 sixx C KR 6 R900 sixx KR 6 R900 sixx W KR 6 R900 sixx C
Number of axes	6
Number of controlled axes	6
Volume of working envelope	KR 6 R700 sixx: 1.36 m <sup>3</sup> KR 6 R700 sixx W: 1.36 m <sup>3</sup> KR 6 R700 sixx C: 1.36 m <sup>3</sup> KR 6 R900 sixx: 2.85 m <sup>3</sup> KR 6 R900 sixx W: 2.85 m <sup>3</sup> KR 6 R900 sixx C: 2.85 m <sup>3</sup>
Pose repeatability (ISO 9283)	±0.03 mm

Working envelope reference point	Intersection of axes 4 and 5
Weight	KR 6 R700 sixx: approx. 50 kg KR 6 R700 sixx W: approx. 50 kg KR 6 R700 sixx C: approx. 50 kg KR 6 R900 sixx: approx. 52 kg KR 6 R900 sixx W: approx. 52 kg KR 6 R900 sixx C: approx. 52 kg
Principal dynamic loads	See Loads acting on the foundation
Protection rating of the robot	IP 54 Ready for operation, with connecting cables plugged in (according to EN 60529)
Protection rating of the in-line wrist	IP 54
Sound level	< 70 dB (A) outside the working envelope
Mounting position	Floor, wall, ceiling
Footprint	320 mm x 320 mm
Permissible angle of inclination	-
Standard colors	Base (stationary) and covers on link arm: black (RAL 9011); moving parts: KUKA orange 2567
Controller	KR C4 compact
Transformation name	KR 6 R700 sixx: KR6R700 C4SR FLR KR 6 R700 sixx W: KR6R700 C4SR WLL KR 6 R700 sixx C: KR6R700 C4SR CLG KR 6 R900 sixx: KR6R900 C4SR FLR KR 6 R900 sixx W: KR6R900 C4SR WLL KR 6 R900 sixx C: KR6R900 C4SR CLG

### Ambient conditions

Operation	278 K to 318 K (+5 °C to +45 °C) No condensation permissible.
Storage and transportation	-40 °C to +60 °C (233 K to 333 K)
Ambient conditions	Relative air humidity ≤ 90% DIN EN 60721-3-3, Class 3K3
Altitude	<ul style="list-style-type: none"> <li>■ up to 1000 m above mean sea level with no reduction in power</li> <li>■ 1000 m ... 4000 m above mean sea level with a reduction in power of 5%/1000 m</li> </ul>

**Connecting cables**

Cable designation	Connector designation robot controller - robot	Interface with robot
Motor cable	X20 - X30	Han Yellock 30
Data cable	X21 - X31	Han Q12
CAT5 data cable (can be ordered as an option)	X65/X66 - XPN1	M12 connector
Connecting cable, external axes A7 and A8 (can be ordered as an option)	XP7 - XP7.1 XP8 - XP8.1	Connector M17 in each case
Ground conductor, equipotential bonding (can be ordered as an option)		Ring cable lug M4

Only resolvers can be connected to the connections XP7.1 and XP8.1.

	Cable lengths
Standard	4 m
Optional	1 m, 7 m, 15 m, 25 m

For detailed specifications of the connecting cables, see (>>> 8.6 "Description of the connecting cables" Page 134).

**4.2 Axis data, KR 6 sixx**

**Axis data**

The following axis data are valid for the robots:

- KR 6 R700 sixx
- KR 6 R700 sixx W
- KR 6 R700 sixx C
- KR 6 R900 sixx
- KR 6 R900 sixx W
- KR 6 R900 sixx C

Axis	Range of motion, software-limited	Speed with rated payload
1	+/-170°	360 °/s
2	+45° to -190°	300 °/s
3	+156° to -120°	360 °/s
4	+/-185°	381 °/s
5	+/-120°	388 °/s
6	+/-350°	615 °/s

The direction of motion and the arrangement of the individual axes may be noted from the diagram (>>> Fig. 4-1 ).



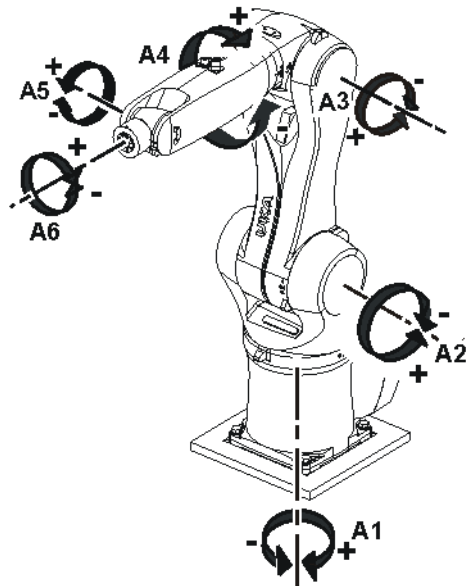
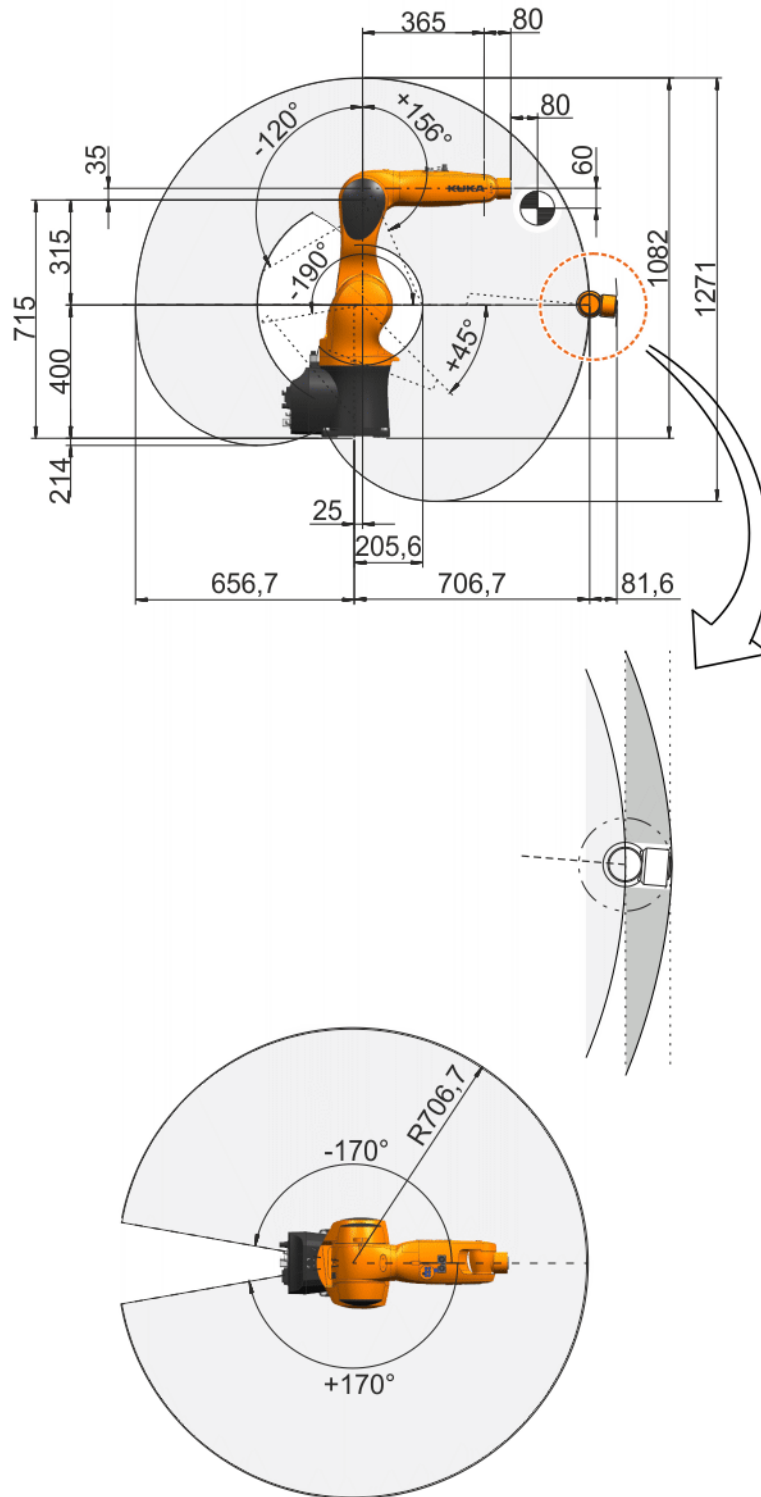

Fig. 4-1: Direction of rotation of robot axes

### Working envelope

The following diagram (>>> Fig. 4-2 ) shows the shape and size of the working envelope for the robot:

- KR 6 R700 sixx

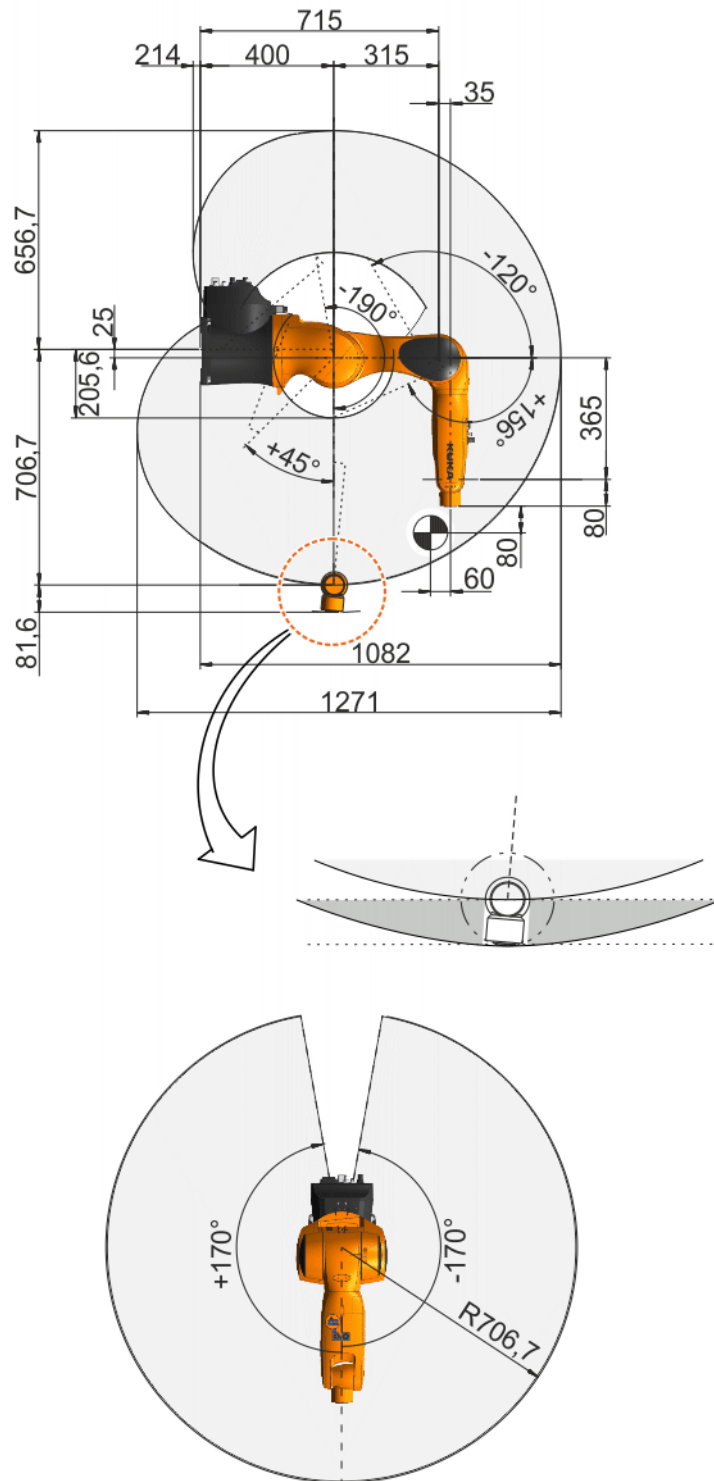

**Fig. 4-2: Working envelope, KR 6 R700 sixx**

The following diagram (>>> Fig. 4-3 ) shows the shape and size of the working envelope for the robot:

- KR 6 R700 sixx W

Dimensions: mm



**Fig. 4-3: Working envelope, KR 6 R700 sixx W**

The following diagram (>>> Fig. 4-4 ) shows the shape and size of the working envelope for the robot:

- KR 6 R700 sixx C

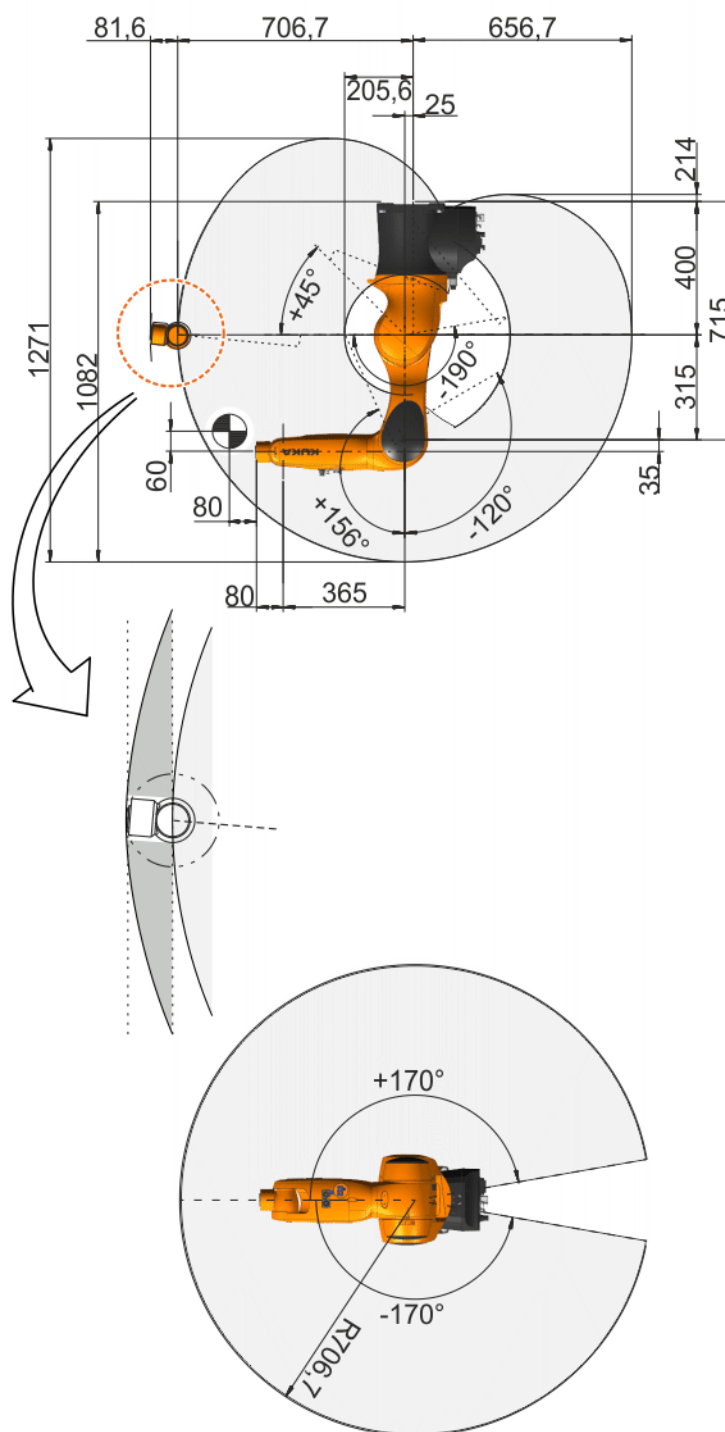
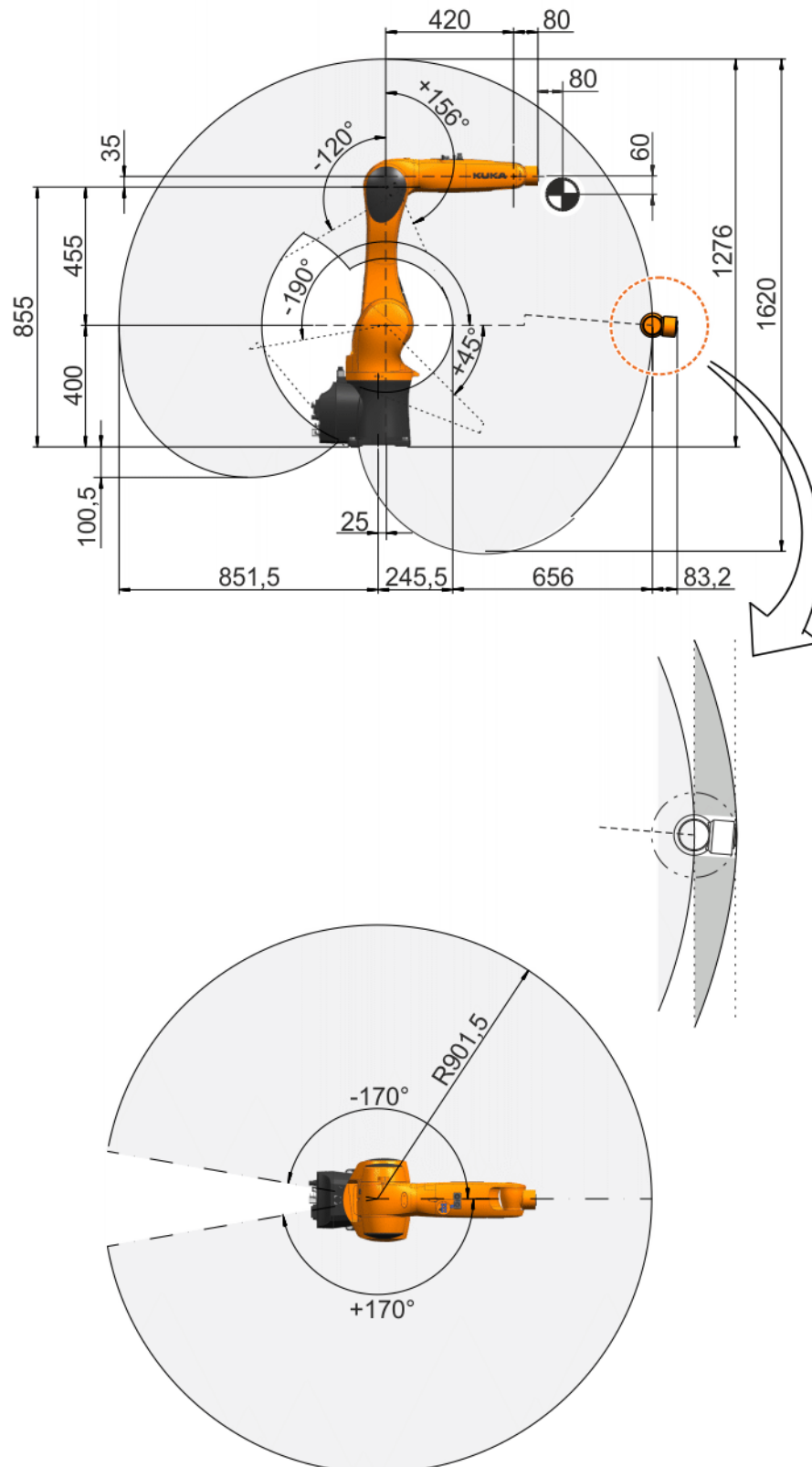

**Fig. 4-4: Working envelope, KR 6 R700 sixx C**

The following diagram (>>> Fig. 4-5 ) shows the shape and size of the working envelope for the robot:

- KR 6 R900 sixx

Dimensions: mm



**Fig. 4-5: Working envelope, KR 6 R900 sixx**

The following diagram (>>> Fig. 4-6 ) shows the shape and size of the working envelope for the robot:

- KR 6 R900 sixx W

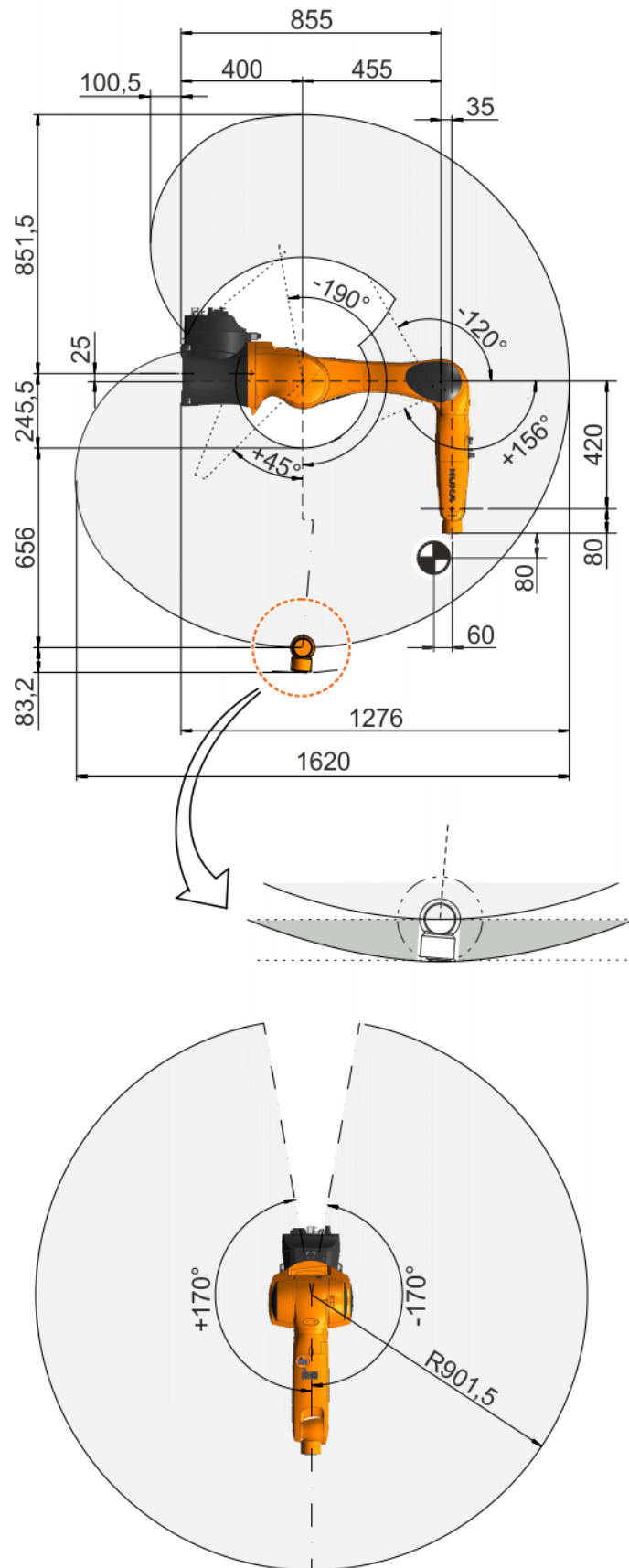

**Fig. 4-6: Working envelope, KR 6 R900 sixx W**

The following diagram (>>> Fig. 4-7 ) shows the shape and size of the working envelope for the robot:

- KR 6 R900 sixx C

Dimensions: mm

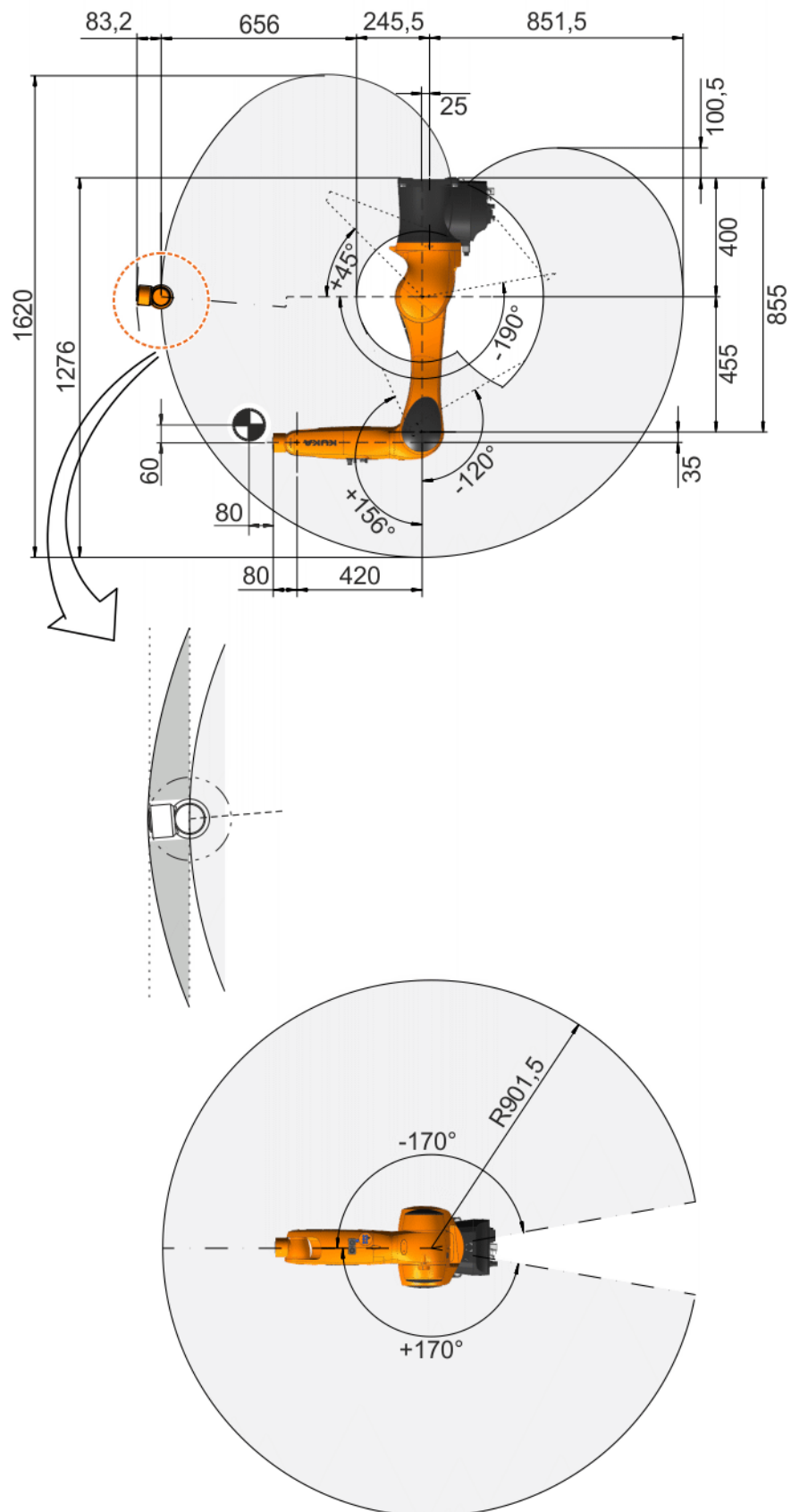

Fig. 4-7: Working envelope, KR 6 R900 sixx C



### 4.3 Payloads, KR 6 sixx

#### Payloads

A distinction is made between the nominal and maximum payload. At the nominal payload, the manipulator is rated for optimal cycle times and accuracy.

Robot	KR 6 R700 sixx KR 6 R700 sixx W KR 6 R700 sixx C KR 6 R900 sixx KR 6 R900 sixx W KR 6 R900 sixx C
In-line wrist	KR 6 R700 sixx: IW 6 R700 KR 6 R900 sixx: IW 6/10 R900
Rated payload	3 kg
Max. payload	6 kg
Distance of the load center of gravity $L_{xy}$	60 mm
Distance of the load center of gravity $L_z$	80 mm
Max. total load	6 kg
Supplementary load	The sum of all loads mounted on the robot must not exceed the maximum total load.

#### Load center of gravity P

For all payloads, the load center of gravity refers to the distance from the face of the mounting flange on axis 6. Refer to the payload diagram for the nominal distance.

#### Payload diagram

Permissible mass inertia at the design point ( $L_x$ ,  $L_y$ ,  $L_z$ ) is 0.045 kgm<sup>2</sup>.

The following figure (>>> Fig. 4-8 ) shows payload diagram for the following robots:

- KR 6 R700 sixx
- KR 6 R700 sixx W
- KR 6 R700 sixx C
- KR 6 R900 sixx
- KR 6 R900 sixx W
- KR 6 R900 sixx C

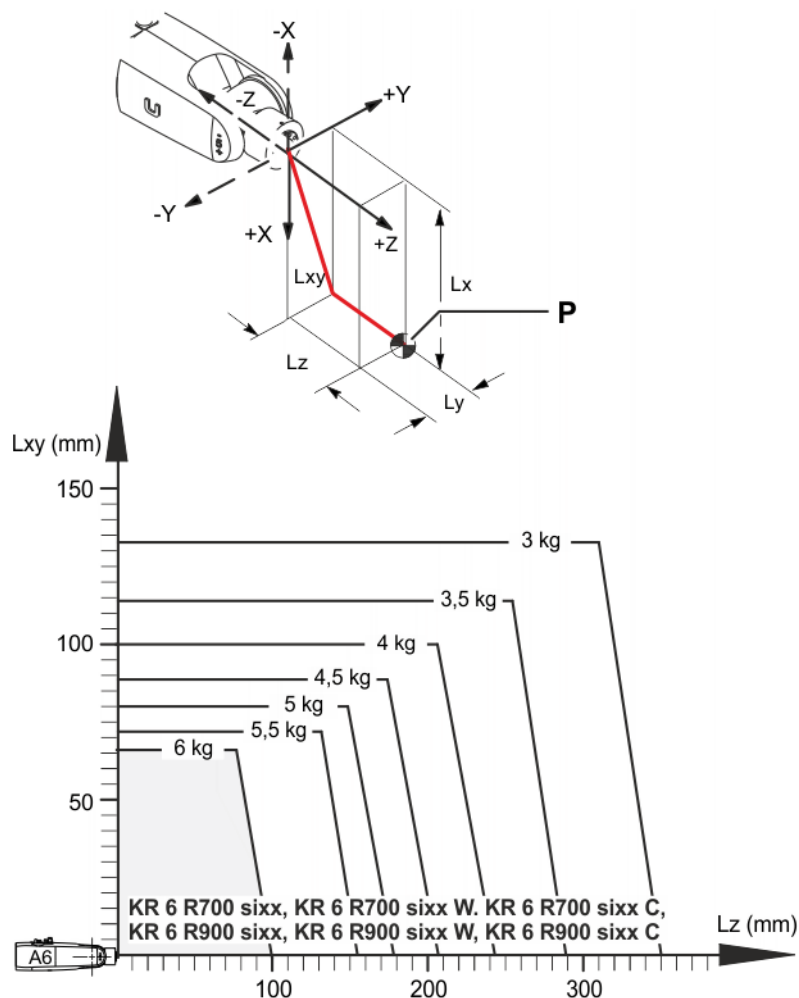

Fig. 4-8: Payload diagram

**NOTICE** This loading curve corresponds to the maximum load capacity. Both values (payload and mass moment of inertia) must be checked in all cases. Exceeding this capacity will reduce the service life of the robot and overload the motors and the gears; in any such case the KUKA Roboter GmbH must be consulted beforehand. The values determined here are necessary for planning the robot application. For commissioning the robot, additional input data are required in accordance with the operating and programming instructions of the KUKA System Software. The mass inertia must be verified using KUKA.Load. It is imperative for the load data to be entered in the robot controller!

### Mounting flange

Mounting flange	31.5 mm
Screw grade	12.9
Screw size	M5
Number of fastening screws	7
Grip length	min. 1.5 x nominal diameter
Depth of engagement	min. 5.5 mm, max. 7 mm
Locating element	5 <sup>H7</sup>
Standard	See illustration (>>> Fig. 4-9)

The mounting flange is depicted (>>> Fig. 4-9) with axis 6 in the zero position. The symbol  $X_m$  indicates the position of the locating element in the zero position.

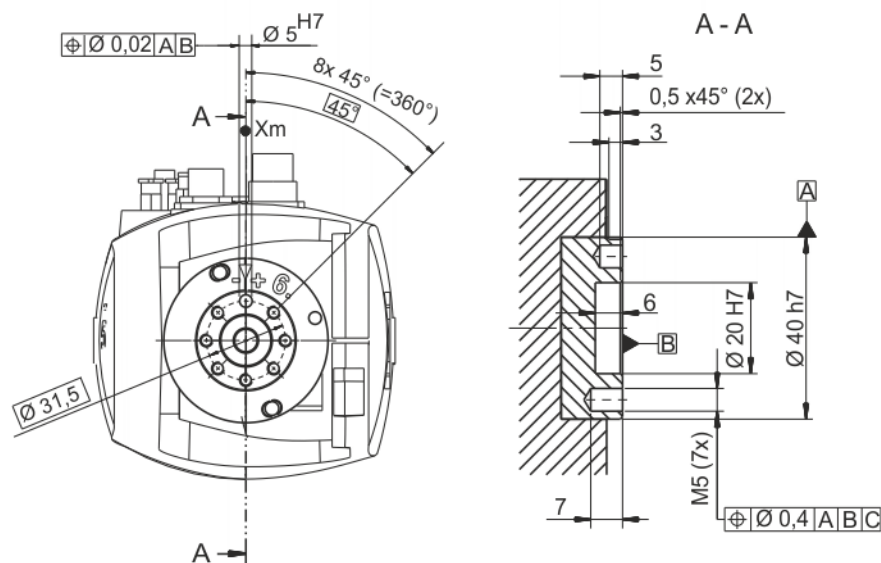

**Fig. 4-9: Mounting flange**

### Supplementary load

The robot can carry supplementary loads on the arm, on the wrist, on the link arm and on the rotating column. The fastening holes are used for fastening the covers or external energy supply systems. When mounting the supplementary loads, be careful to observe the maximum permissible total load. The dimensions and positions of the installation options can be seen in the following diagram.



The sum of all loads mounted on the robot must not exceed the maximum total load.

The following figure (>>> Fig. 4-10 ) shows the dimensions and position of the installation options on the arm and in-line wrist for the following robots:

- KR 6 R700 sixx
- KR 6 R700 sixx W
- KR 6 R700 sixx C

Maße / Dimensions: mm

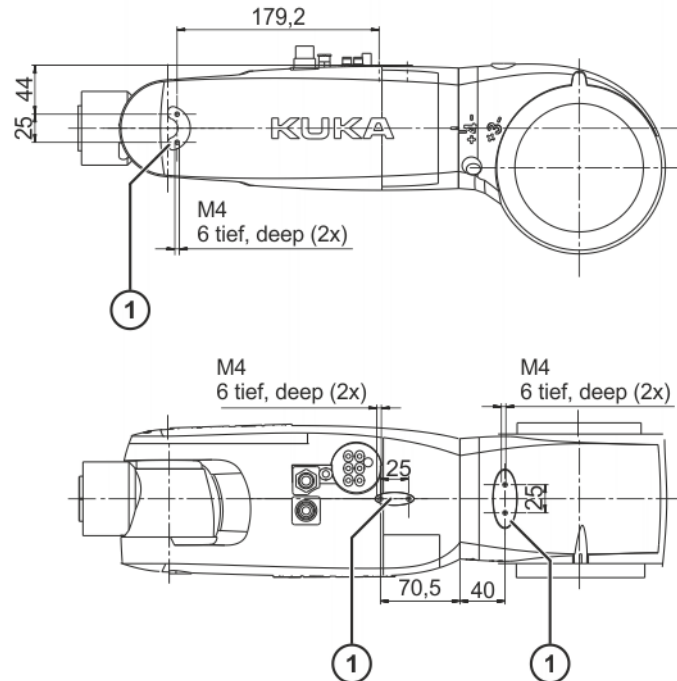

**Fig. 4-10: Supplementary load on arm and in-line wrist**

- 1 Support bracket for supplementary load

The following figure (>>> Fig. 4-11 ) shows the dimensions and position of the installation options on the link arm and rotating column for the following robots:

- KR 6 R700 sixx
- KR 6 R700 sixx W
- KR 6 R700 sixx C

Maße / Dimensions: mm

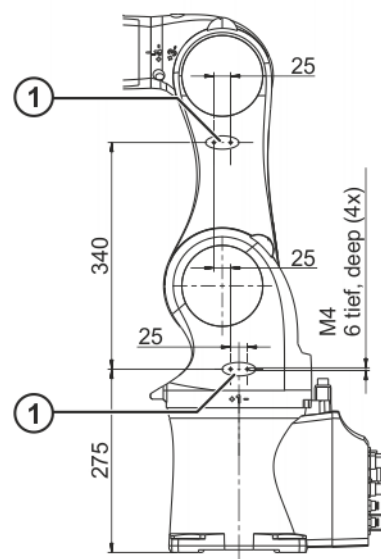

**Fig. 4-11: Supplementary load on link arm and rotating column**

- 1 Support bracket for supplementary load

The following figure (>>> Fig. 4-12 ) shows the dimensions and position of the installation options on the arm and in-line wrist for the following robots:

- KR 6 R900 sixx
- KR 6 R900 sixx W
- KR 6 R900 sixx C

Dimensions: mm

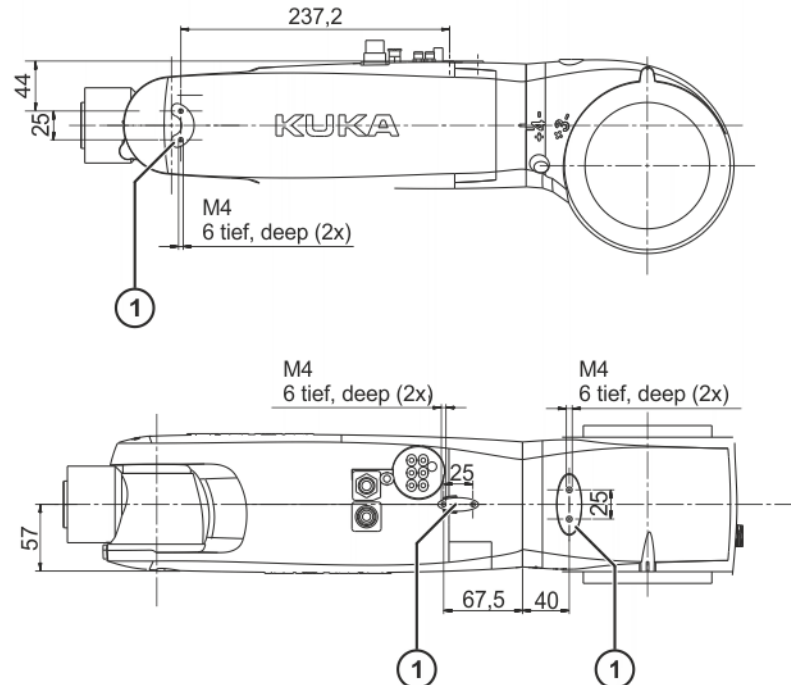

**Fig. 4-12: Supplementary load on arm and in-line wrist**

- 1 Support bracket for supplementary load

The following figure (>>> Fig. 4-13 ) shows the dimensions and position of the installation options on the link arm and rotating column for the following robots:

- KR 6 R900 sixx
- KR 6 R900 sixx W
- KR 6 R900 sixx C

Dimensions: mm

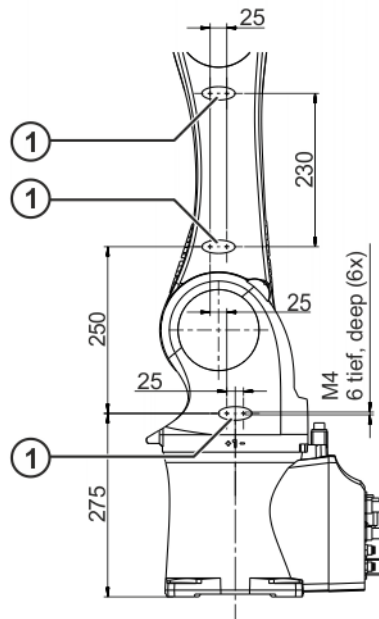

Fig. 4-13: Supplementary load on link arm and rotating column

- 1 Support bracket for supplementary load

#### 4.4 Foundation data, KR 6 sixx

**Foundation loads** The specified forces and moments already include the maximum payload and the inertia force (weight) of the robot.

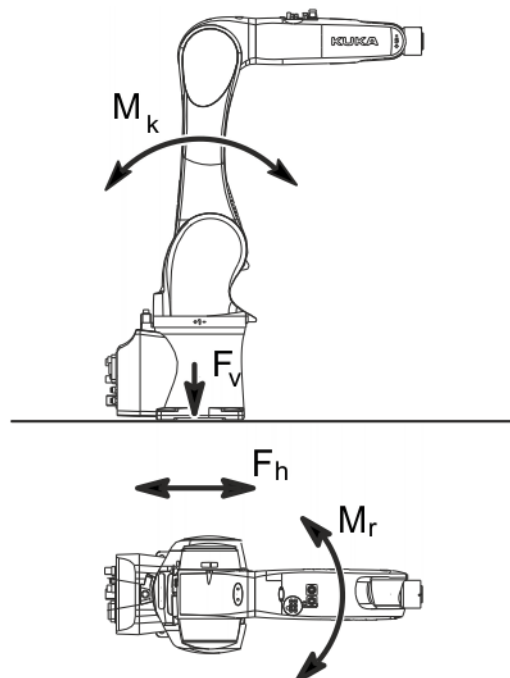

Fig. 4-14: Loads acting on the foundation, floor mounting

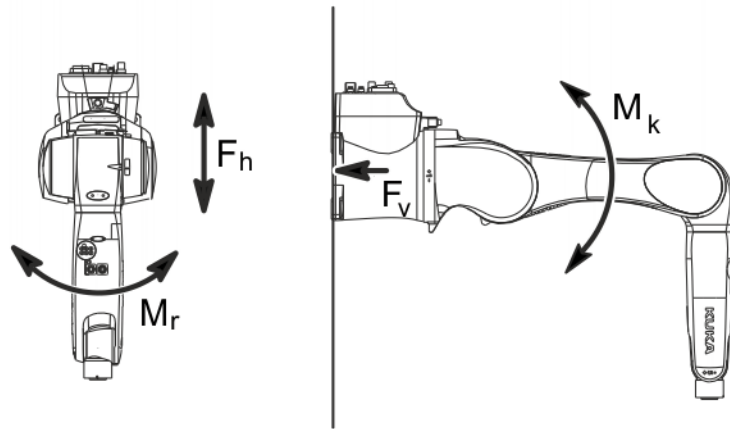

Fig. 4-15: Loads acting on the foundation, wall mounting

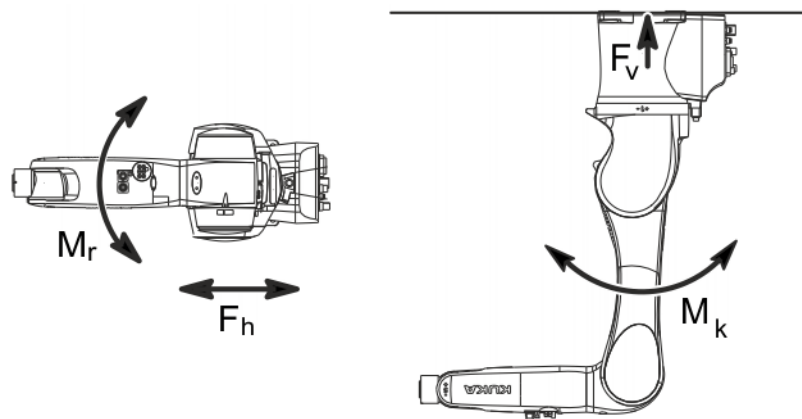

Fig. 4-16: Loads acting on the foundation, ceiling mounting

Type of load	Force/torque/mass	
	Normal operation	Maximum load
$F_v$ = vertical force	$F_{v \text{ normal}} = 967 \text{ N}$	$F_{v \text{ max}} = 1297 \text{ N}$
$F_h$ = horizontal force	$F_{h \text{ normal}} = 1223 \text{ N}$	$F_{v \text{ max}} = 1362 \text{ N}$
$M_k$ = tilting moment	$M_{k \text{ normal}} = 788 \text{ Nm}$	$M_{k \text{ max}} = 1152 \text{ Nm}$
$M_r$ = torque	$M_{r \text{ normal}} = 367 \text{ Nm}$	$M_{r \text{ max}} = 880 \text{ Nm}$
Total mass for foundation load	KR 6 R700 sixx: 56 kg KR 6 R900 sixx: 58 kg	
Robot	KR 6 R700 sixx: 50 kg KR 6 R900 sixx: 52 kg	
Total load for foundation load (suppl. load on arm + rated payload)	KR 6 R700 sixx: 6 kg KR 6 R900 sixx: 6 kg	



**⚠ CAUTION** Normal loads and maximum loads for the foundations are specified in the table.

The maximum loads must be referred to when dimensioning the foundations and must be adhered to for safety reasons. Failure to do so may result in material damage.

The normal loads are average expected foundation loads. The actual loads are dependent on the program and on the robot loads and may therefore be greater or less than the normal loads.

The supplementary loads are not taken into consideration in the calculation of the foundation load. These supplementary loads must be taken into consideration for  $F_v$ .

#### 4.5 Basic data, KR 10 sixx

##### Basic data

Type	KR 10 R900 sixx KR 10 R900 sixx W KR 10 R900 sixx C KR 10 R1100 sixx KR 10 R1100 sixx W KR 10 R1100 sixx C
Number of axes	6
Number of controlled axes	6
Volume of working envelope	KR 10 R900 sixx: 2.85 m <sup>3</sup> KR 10 R900 sixx W: 2.85 m <sup>3</sup> KR 10 R900 sixx C: 2.85 m <sup>3</sup> KR 10 R1100 sixx: 5.20 m <sup>3</sup> KR 10 R1100 sixx W: 5.20 m <sup>3</sup> KR 10 R1100 sixx C: 5.20 m <sup>3</sup>
Pose repeatability (ISO 9283)	±0.03 mm
Working envelope reference point	Intersection of axes 4 and 5
Weight	KR 10 R900 sixx: approx. 52 kg KR 10 R900 sixx W: approx. 52 kg KR 10 R900 sixx C: approx. 52 kg KR 10 R1100 sixx: approx. 55 kg KR 10 R1100 sixx W: approx. 55 kg KR 10 R1100 sixx C: approx. 55 kg
Principal dynamic loads	See Loads acting on the foundation
Protection rating of the robot	IP 54 Ready for operation, with connecting cables plugged in (according to EN 60529)
Protection rating of the in-line wrist	IP 54
Sound level	< 70 dB (A) outside the working envelope

Mounting position	Floor, wall, ceiling
Footprint	320 mm x 320 mm
Permissible angle of inclination	-
Standard colors	Base (stationary) and covers on link arm: black (RAL 9011); moving parts: KUKA orange 2567
Controller	KR C4 compact
Transformation name	KR 10 R900 sixx: KR10R900 C4SR FLR KR 10 R900 sixx W: KR10R900 C4SR WLL KR 10 R900 sixx C: KR10R900 C4SR CLG KR 10 R1100 sixx: KR10R1100 C4SR FLR KR 10 R1100 sixx W: KR10R1100 C4SR WLL KR 10 R1100 sixx C: KR10R1100 C4SR CLG

**Ambient conditions**

Operation	278 K to 318 K (+5 °C to +45 °C) No condensation permissible.
Storage and transportation	-40 °C to +60 °C (233 K to 333 K)
Ambient conditions	Relative air humidity ≤ 90% DIN EN 60721-3-3, Class 3K3
Altitude	<ul style="list-style-type: none"> <li>■ up to 1000 m above mean sea level with no reduction in power</li> <li>■ 1000 m ... 4000 m above mean sea level with a reduction in power of 5%/1000 m</li> </ul>

**Connecting cables**

Cable designation	Connector designation robot controller - robot	Interface with robot
Motor cable	X20 - X30	Han Yellowlock 30
Data cable	X21 - X31	Han Q12
CAT5 data cable (can be ordered as an option)	X65/X66 - XPN1	M12 connector
Connecting cable, external axes A7 and A8 (can be ordered as an option)	XP7 - XP7.1 XP8 - XP8.1	Connector M17 in each case
Ground conductor, equipotential bonding (can be ordered as an option)		Ring cable lug M4

Only resolvers can be connected to the connections XP7.1 and XP8.1.

	Cable lengths
Standard	4 m
Optional	1 m, 7 m, 15 m, 25 m

For detailed specifications of the connecting cables, see (>>> 8.6 "Description of the connecting cables" Page 134).

## 4.6 Axis data, KR 10 sixx

### Axis data

The following axis data are valid for the robots:

- KR 10 R900 sixx
- KR 10 R900 sixx W
- KR 10 R900 sixx C
- KR 10 R1100 sixx
- KR 10 R1100 sixx W
- KR 10 R1100 sixx C

Axis	Range of motion, software-limited	Speed with rated payload
1	+/-170°	300 °/s
2	+45° to -190°	225 °/s
3	+156° to -120°	225 °/s
4	+/-185°	381 °/s
5	+/-120°	311 °/s
6	+/-350°	492 °/s

The direction of motion and the arrangement of the individual axes may be noted from the diagram ( >>> Fig. 4-17 ).

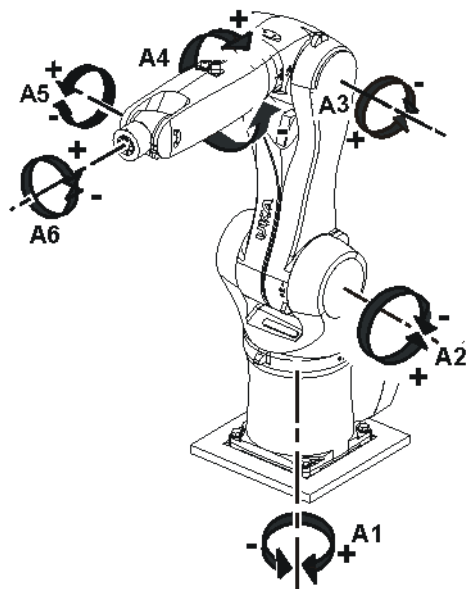

Fig. 4-17: Direction of rotation of robot axes

### Working envelope

The following diagram ( >>> Fig. 4-18 ) shows the shape and size of the working envelope for the robot:

- KR 10 R900 sixx

Dimensions: mm

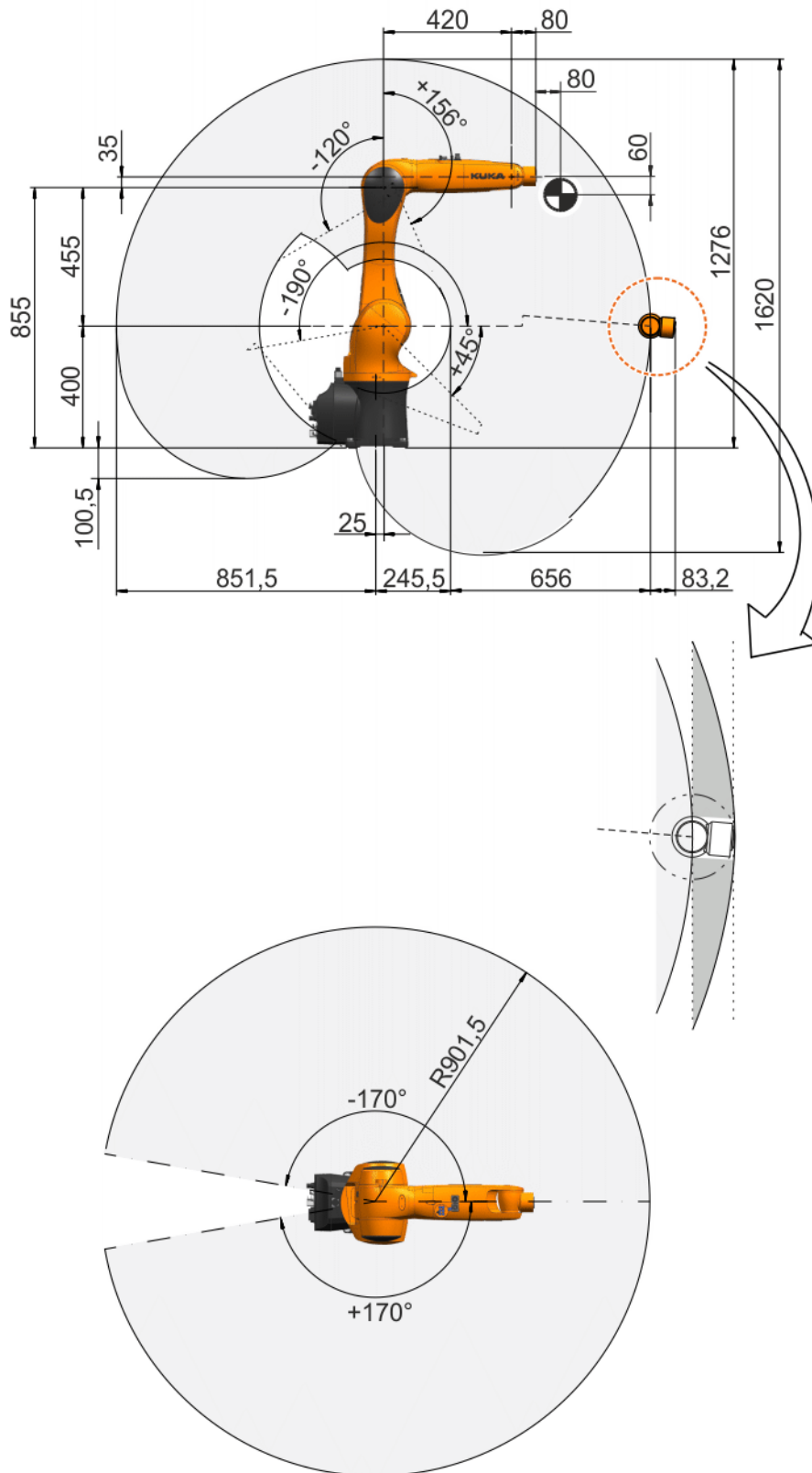
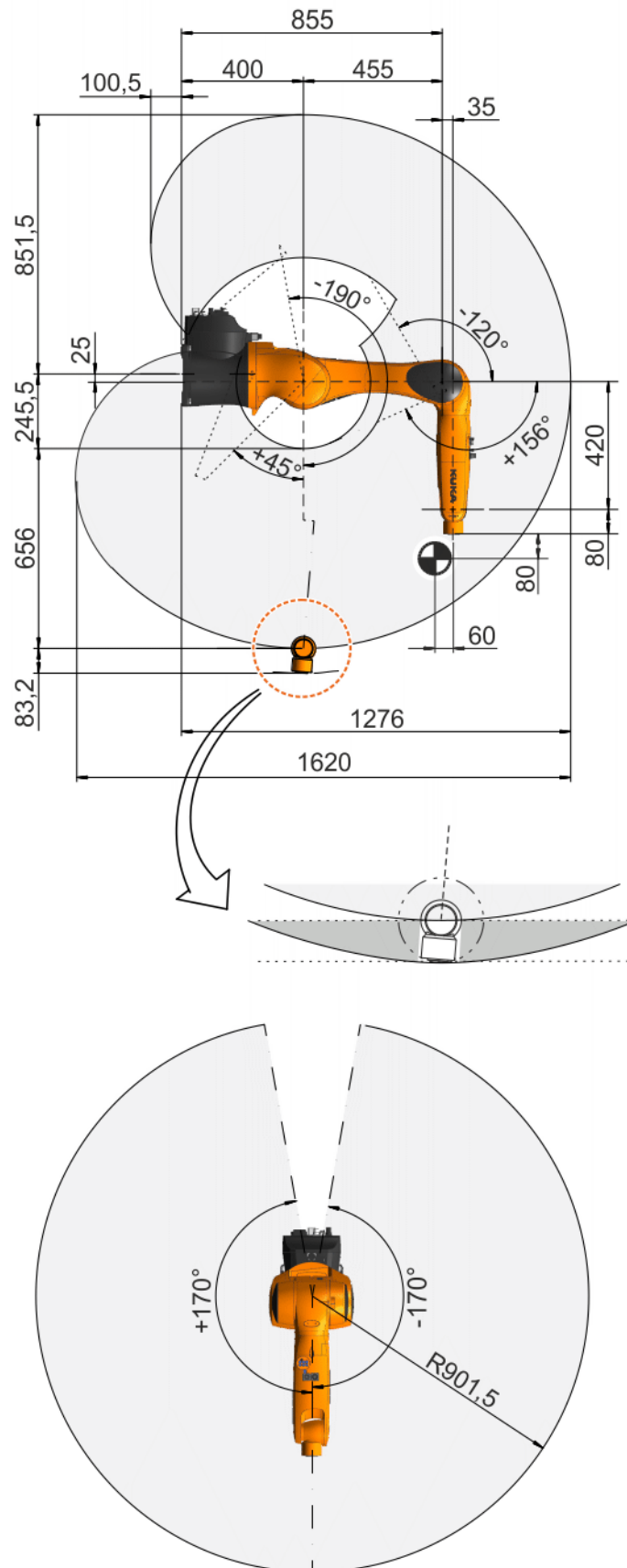

**Fig. 4-18: Working envelope, KR 10 R900 sixx**

The following diagram (>>> Fig. 4-19 ) shows the shape and size of the working envelope for the robot:

- KR 10 R900 sixx W

Dimensions: mm



**Fig. 4-19: Working envelope, KR 10 R900 sixx W**

The following diagram (>>> Fig. 4-20 ) shows the shape and size of the working envelope for the robot:

■ KR 10 R900 sixx C

Dimensions: mm

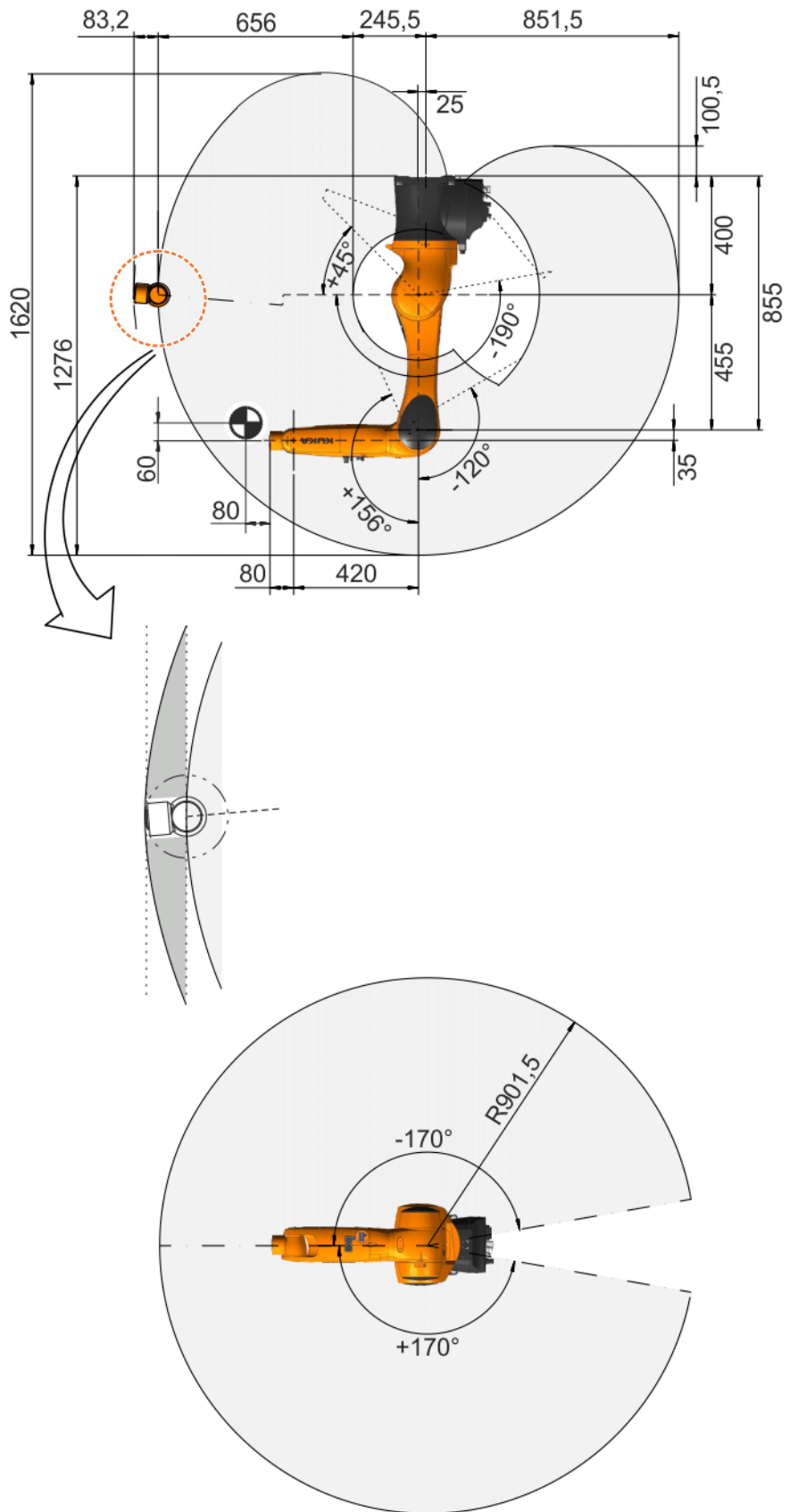

Fig. 4-20: Working envelope, KR 10 R900 sixx C

The following diagram (>>> Fig. 4-21 ) shows the shape and size of the working envelope for the robot:

- KR 10 R1100 sixx

Dimensions: mm

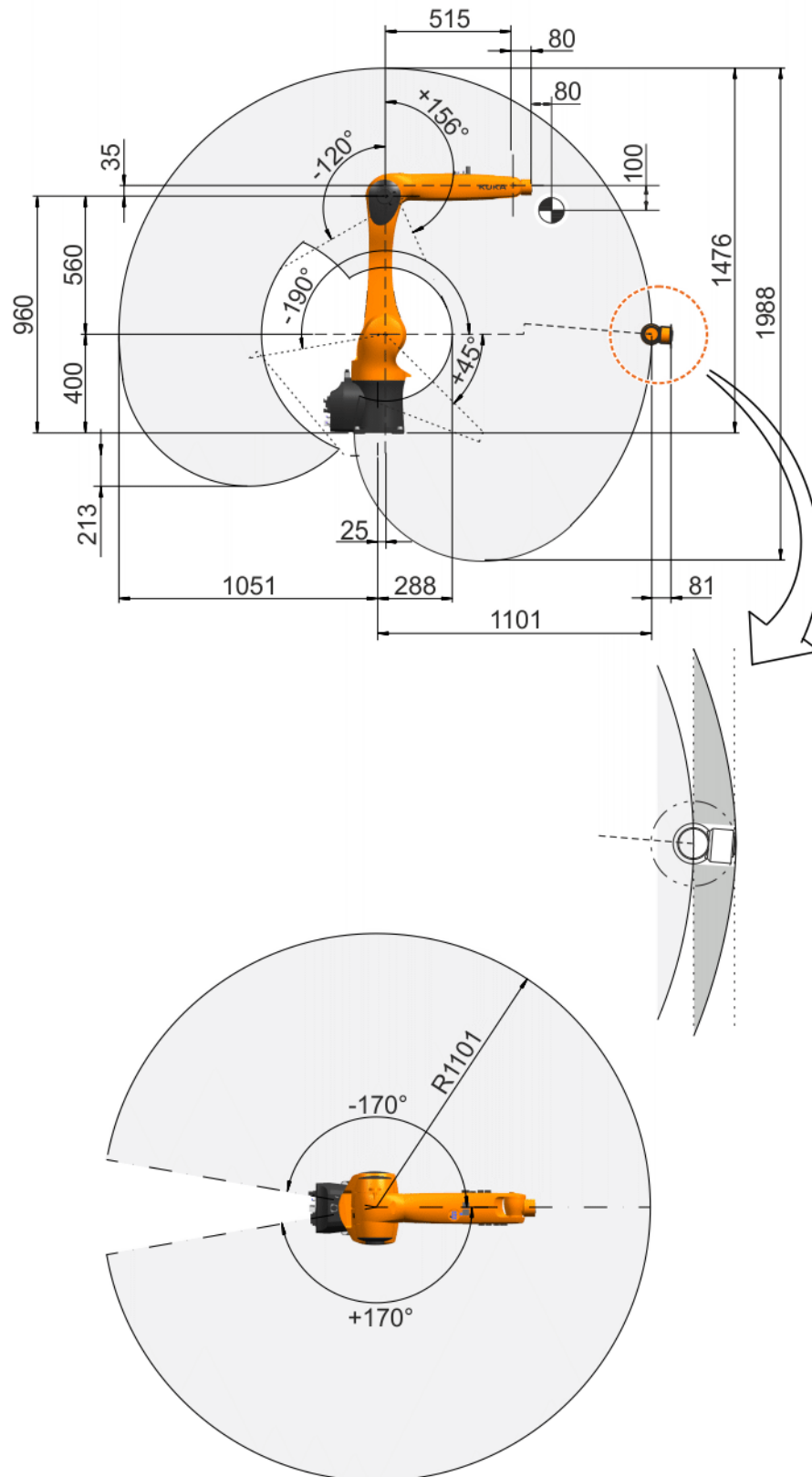

Fig. 4-21: Working envelope, KR 10 R1100 sixx

The following diagram (>>> Fig. 4-22 ) shows the shape and size of the working envelope for the robot:

- KR 10 R1100 sixx W



Dimensions: mm

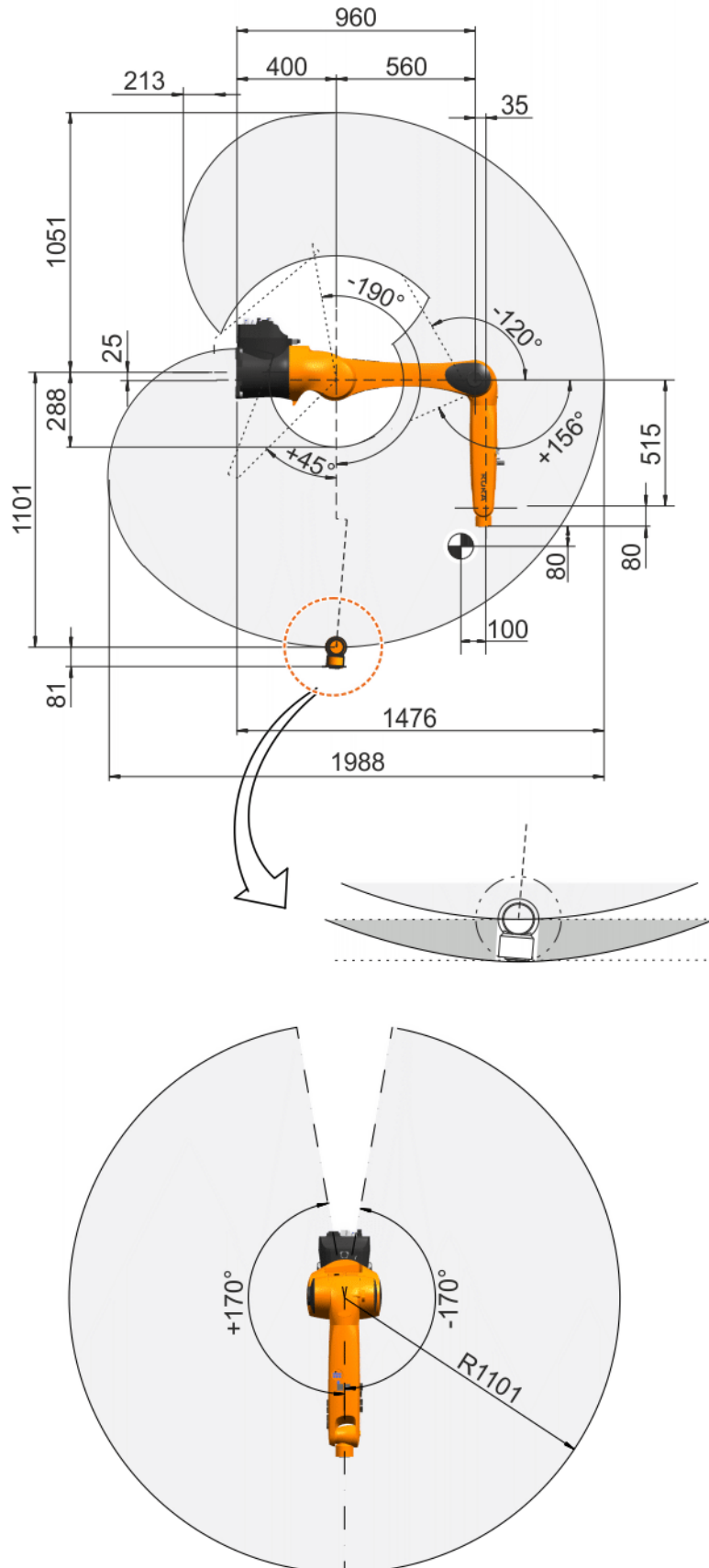

**Fig. 4-22: Working envelope, KR 10 R1100 sixx W**

The following diagram (>>> Fig. 4-23 ) shows the shape and size of the working envelope for the robot:

■ KR 10 R1100 sixx C

Dimensions: mm

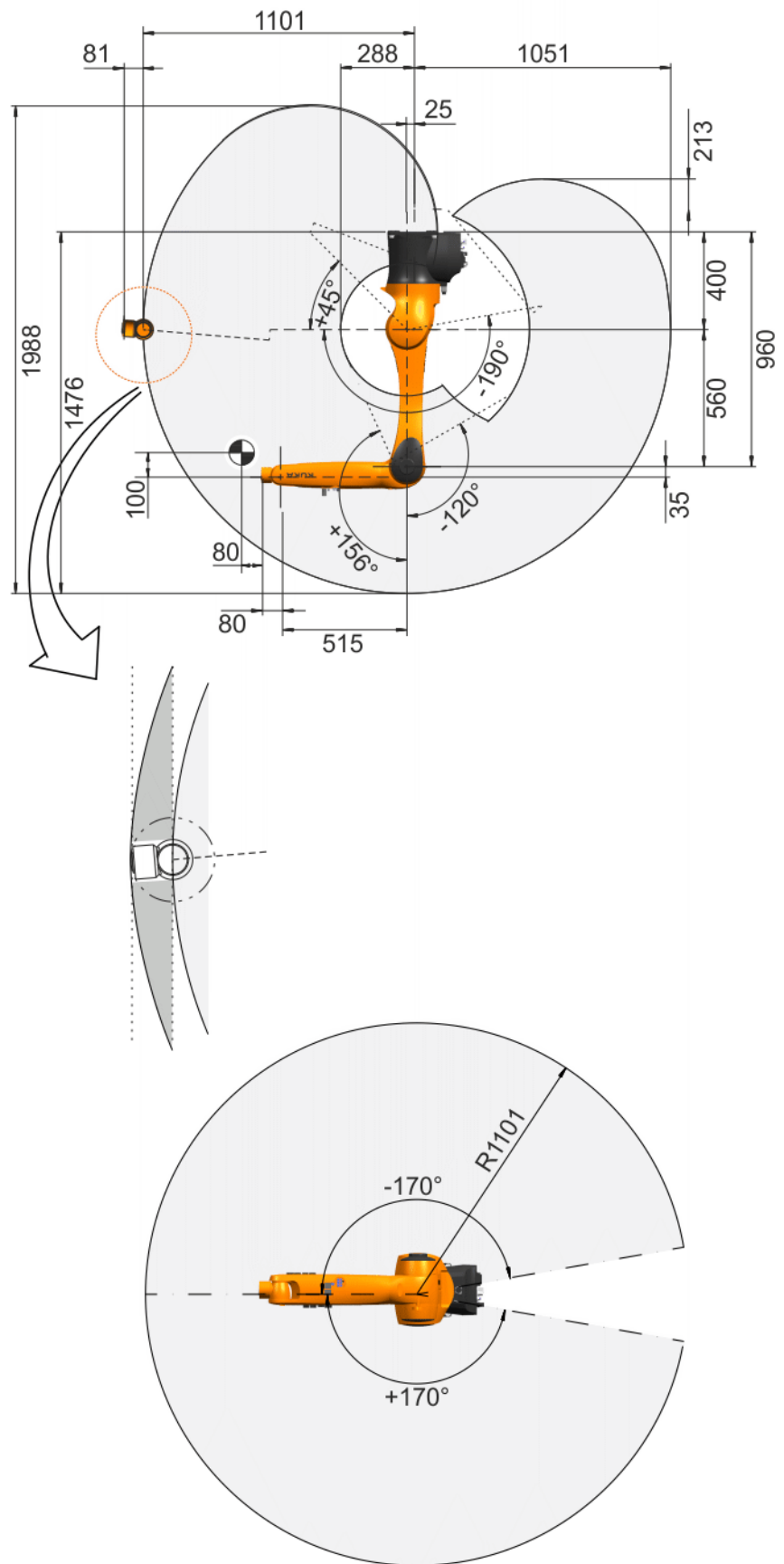

Fig. 4-23: Working envelope, KR 10 R1100 sixx C

## 4.7 Payloads, KR 10 sixx

### Payloads

A distinction is made between the nominal and maximum payload. At the nominal payload, the manipulator is rated for optimal cycle times and accuracy.

Robot	KR 10 R900 sixx KR 10 R900 sixx W KR 10 R900 sixx C KR 10 R1100 sixx KR 10 R1100 sixx W KR 10 R1100 sixx C
In-line wrist	KR 10 R900 sixx: IW 6/10 R900 KR 10 R1100 sixx: IW 10 R1100
Rated payload	5 kg
Max. payload	10 kg
Distance of the load center of gravity $L_{xy}$	100 mm
Distance of the load center of gravity $L_z$	80 mm
Max. total load	10 kg
Supplementary load	The sum of all loads mounted on the robot must not exceed the maximum total load.

### Load center of gravity P

For all payloads, the load center of gravity refers to the distance from the face of the mounting flange on axis 6. Refer to the payload diagram for the nominal distance.

### Payload diagram

Permissible mass inertia at the design point ( $L_x$ ,  $L_y$ ,  $L_z$ ) is 0.045 kgm<sup>2</sup>.

The following figure (>>> Fig. 4-24 ) shows payload diagram for the following robots:

- KR 10 R900 sixx
- KR 10 R900 sixx W
- KR 10 R900 sixx C

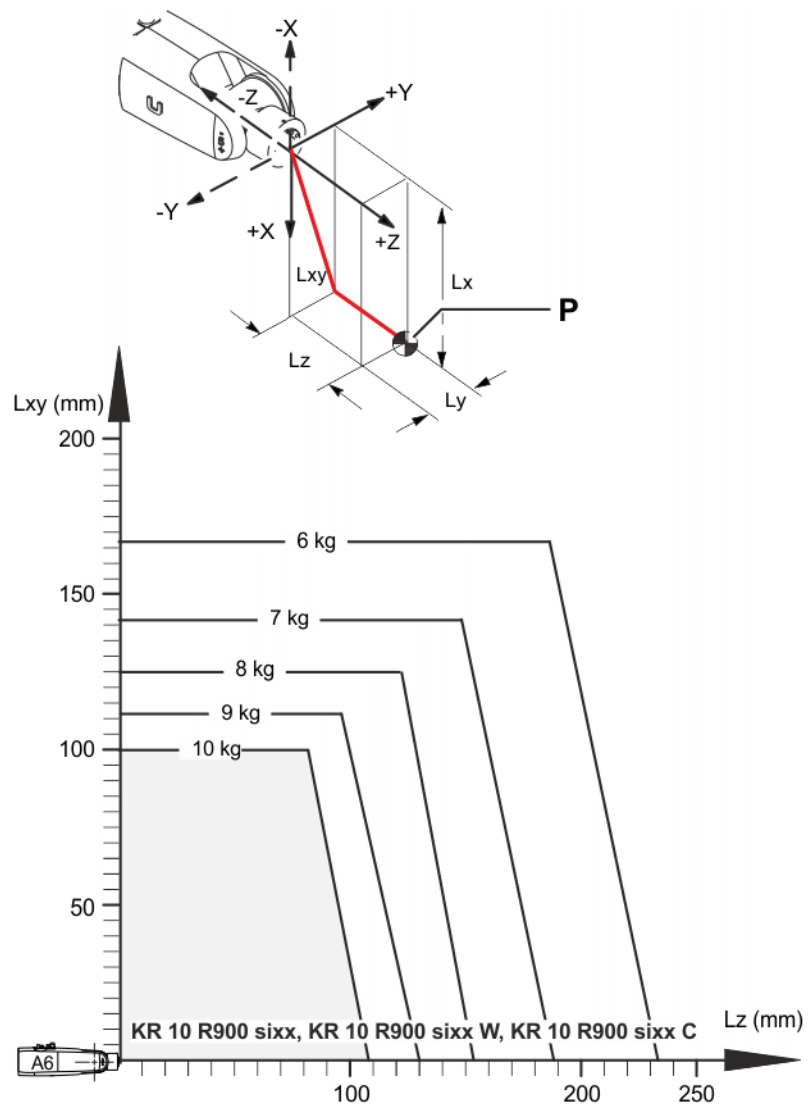

**Fig. 4-24: Payload diagram, KR 10 R900 sixx**

The following figure (>>> Fig. 4-25 ) shows payload diagram for the following robots:

- KR 10 R1100 sixx
- KR 10 R1100 sixx W
- KR 10 R1100 sixx C

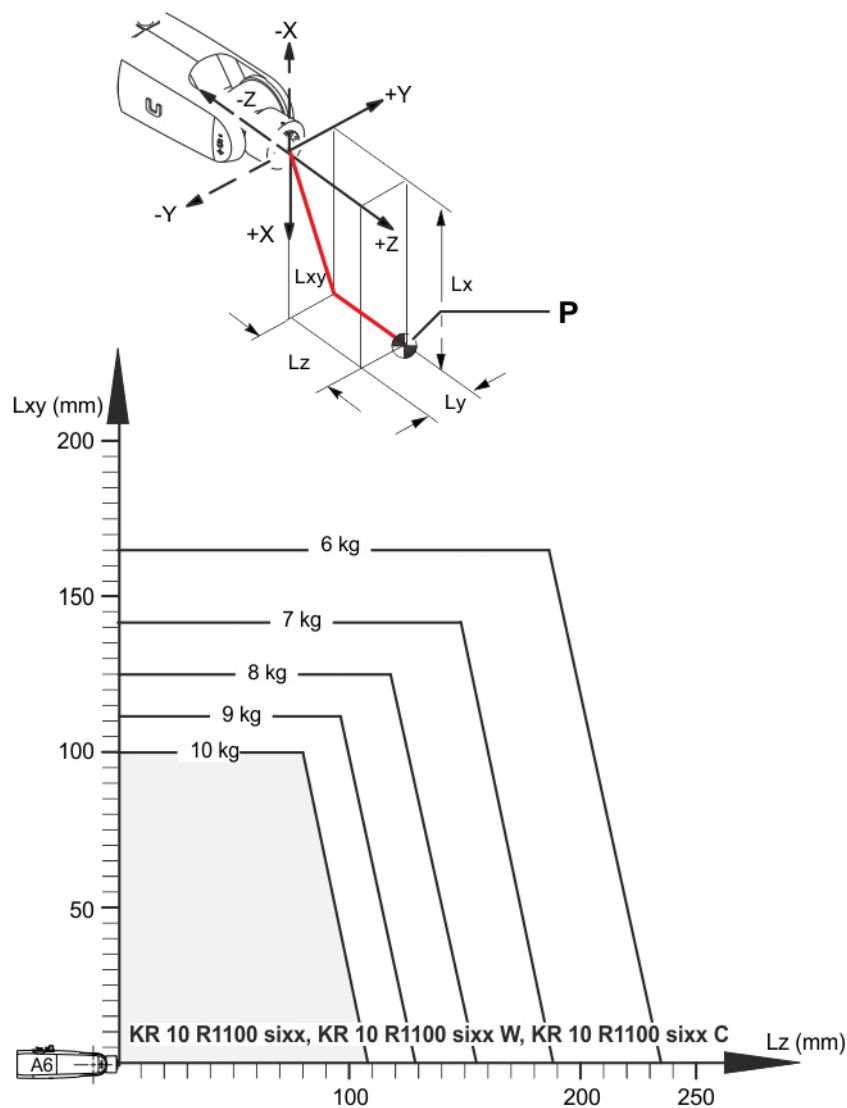

Fig. 4-25: Payload diagram, KR 10 R1100 sixx

### NOTICE

This loading curve corresponds to the maximum load capacity. Both values (payload and mass moment of inertia) must be checked in all cases. Exceeding this capacity will reduce the service life of the robot and overload the motors and the gears; in any such case the KUKA Roboter GmbH must be consulted beforehand.

The values determined here are necessary for planning the robot application. For commissioning the robot, additional input data are required in accordance with the operating and programming instructions of the KUKA System Software.

The mass inertia must be verified using KUKA.Load. It is imperative for the load data to be entered in the robot controller!

### Mounting flange

Mounting flange	31.5 mm
Screw grade	12.9
Screw size	M5
Number of fastening screws	7
Grip length	min. 1.5 x nominal diameter
Depth of engagement	min. 5.5 mm, max. 7 mm
Locating element	5 <sup>H7</sup>
Standard	See illustration (>>> Fig. 4-26 )

The mounting flange is depicted (>>> Fig. 4-26 ) with axis 6 in the zero position. The symbol  $X_m$  indicates the position of the locating element in the zero position.

Maße / Dimensions: mm

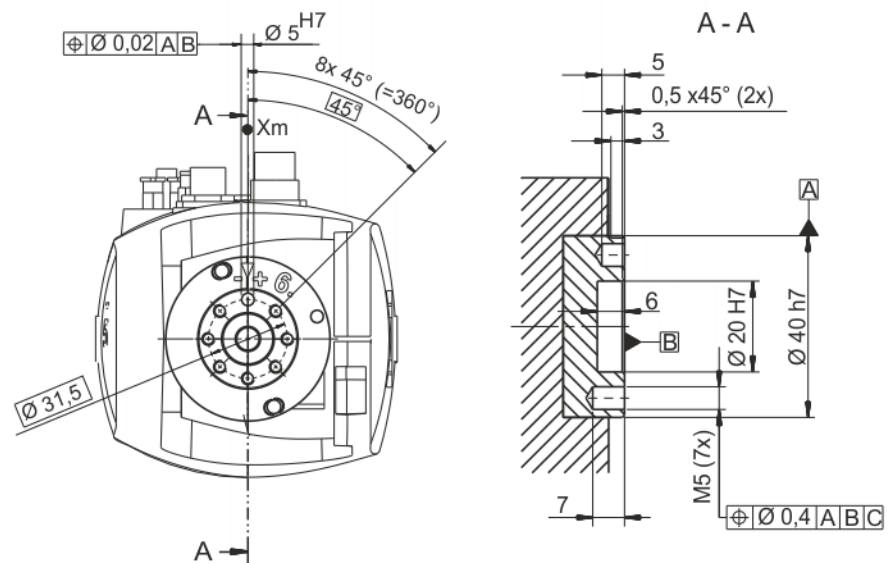

**Fig. 4-26: Mounting flange**

### Supplementary load

The robot can carry supplementary loads on the arm, on the wrist, on the link arm and on the rotating column. The fastening holes are used for fastening the covers or external energy supply systems. When mounting the supplementary loads, be careful to observe the maximum permissible total load. The dimensions and positions of the installation options can be seen in the following diagram.



The sum of all loads mounted on the robot must not exceed the maximum total load.

The following figure (>>> Fig. 4-27 ) shows the dimensions and position of the installation options on the arm and in-line wrist for the following robots:

- KR 10 R900 sixx
- KR 10 R900 sixx W
- KR 10 R900 sixx C

Maße / Dimensions: mm

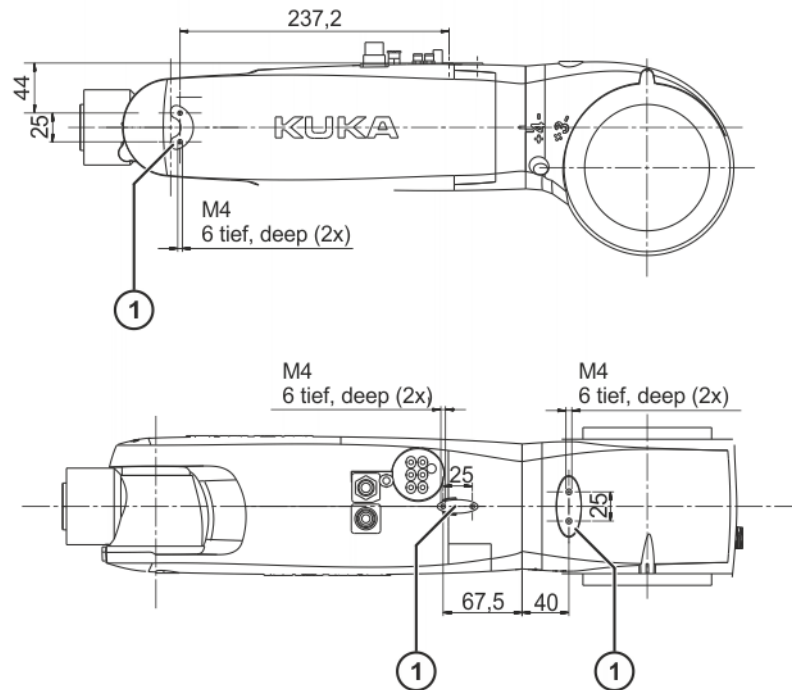

**Fig. 4-27: Supplementary load on arm and in-line wrist**

- 1 Support bracket for supplementary load

The following figure (>>> Fig. 4-28 ) shows the dimensions and position of the installation options on the link arm and rotating column for the following robots:

- KR 10 R900 sixx
- KR 10 R900 sixx W
- KR 10 R900 sixx C

Maße / Dimensions: mm

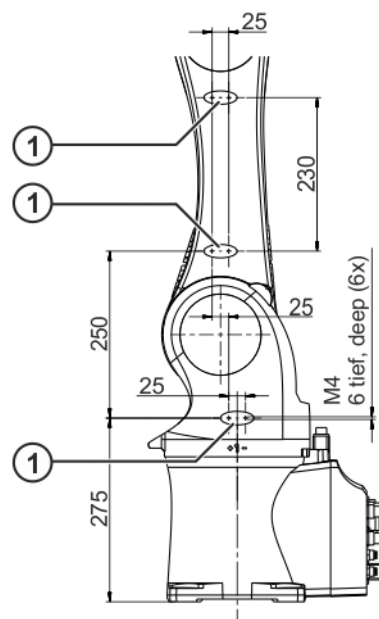

**Fig. 4-28: Supplementary load on link arm and rotating column**

- 1 Support bracket for supplementary load

The following figure (>>> Fig. 4-29 ) shows the dimensions and position of the installation options on the arm and in-line wrist for the following robots:

- KR 10 R1100 sixx
- KR 10 R1100 sixx W
- KR 10 R1100 sixx C

Maße / Dimensions: mm

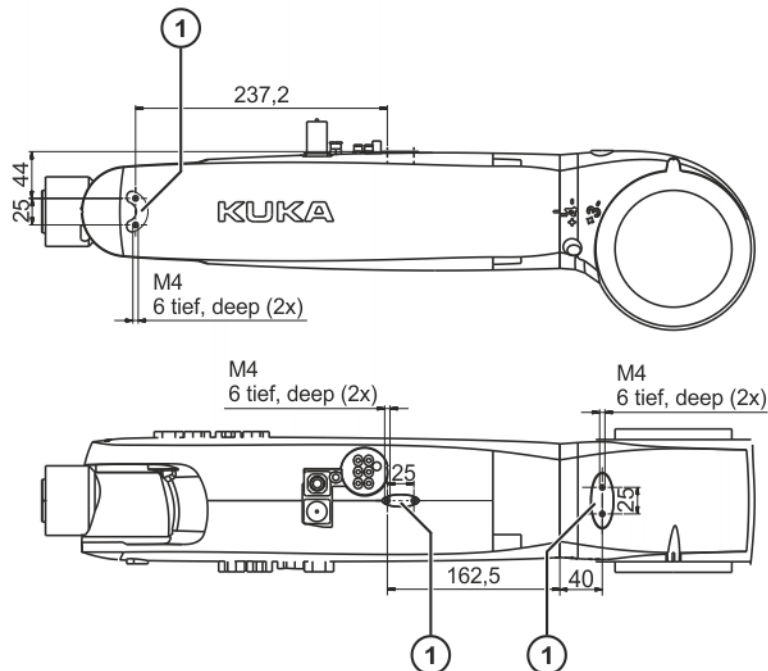

**Fig. 4-29: Supplementary load on arm and in-line wrist**

- 1 Support bracket for supplementary load

The following figure (>>> Fig. 4-30 ) shows the dimensions and position of the installation options on the link arm and rotating column for the following robots:

- KR 10 R1100 sixx
- KR 10 R1100 sixx W
- KR 10 R1100 sixx C



Maße / Dimensions: mm

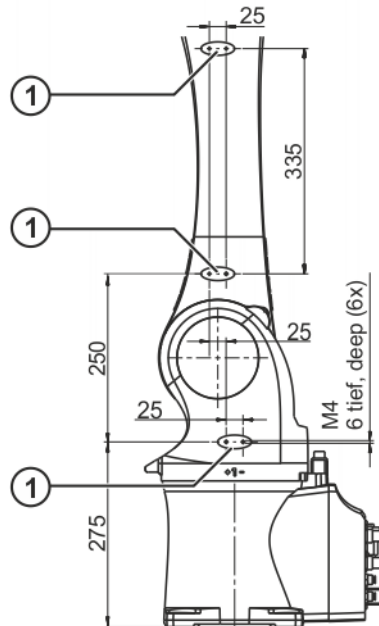

Fig. 4-30: Supplementary load on link arm and rotating column

- 1 Support bracket for supplementary load

#### 4.8 Foundation data, KR 10 sixx

**Foundation loads** The specified forces and moments already include the maximum payload and the inertia force (weight) of the robot.

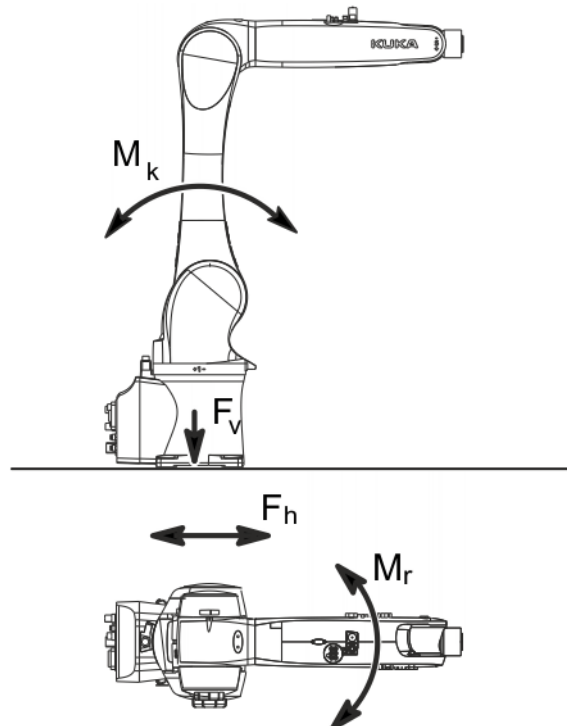

Fig. 4-31: Loads acting on the foundation, floor mounting

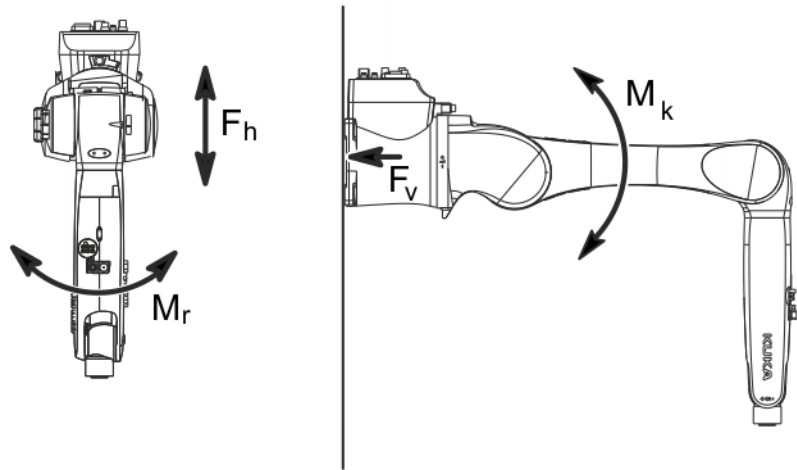

Fig. 4-32: Loads acting on the foundation, wall mounting

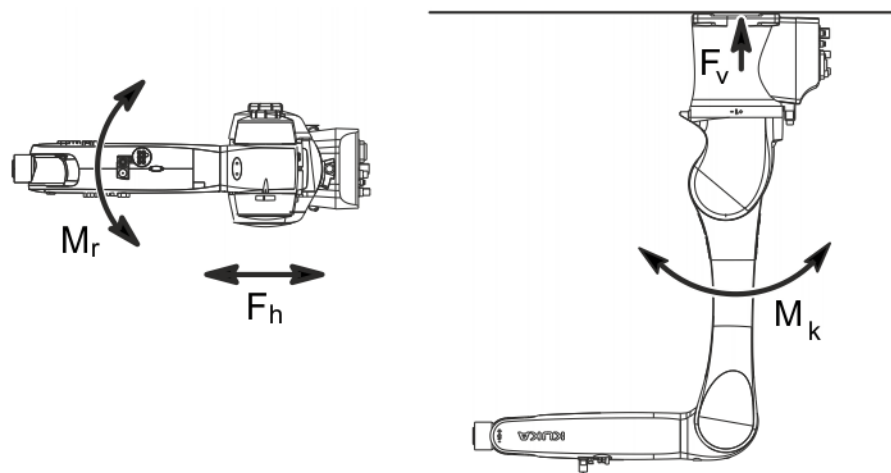

Fig. 4-33: Loads acting on the foundation, ceiling mounting

Type of load	Force/torque/mass	
	Normal operation	Maximum load
$F_v$ = vertical force	$F_{v \text{ normal}} = 967 \text{ N}$	$F_{v \text{ max}} = 1297 \text{ N}$
$F_h$ = horizontal force	$F_{h \text{ normal}} = 1223 \text{ N}$	$F_{v \text{ max}} = 1362 \text{ N}$
$M_k$ = tilting moment	$M_{k \text{ normal}} = 788 \text{ Nm}$	$M_{k \text{ max}} = 1152 \text{ Nm}$
$M_r$ = torque	$M_{r \text{ normal}} = 367 \text{ Nm}$	$M_{r \text{ max}} = 880 \text{ Nm}$
Total mass for foundation load	KR 10 R900 sixx: 62 kg KR 10 R1100 sixx: 65 kg	
Robot	KR 10 R900 sixx: 52 kg KR 10 R1100 sixx: 55 kg	
Total load for foundation load (suppl. load on arm + rated payload)	KR 10 R900 sixx: 10 kg KR 10 R1100 sixx: 10 kg	

**⚠ CAUTION** Normal loads and maximum loads for the foundations are specified in the table.

The maximum loads must be referred to when dimensioning the foundations and must be adhered to for safety reasons. Failure to do so may result in material damage.

The normal loads are average expected foundation loads. The actual loads are dependent on the program and on the robot loads and may therefore be greater or less than the normal loads.

The supplementary loads are not taken into consideration in the calculation of the foundation load. These supplementary loads must be taken into consideration for  $F_v$ .

#### 4.9 Plates and labels

**Plates and labels** The following plates and labels are attached to the robot. They must not be removed or rendered illegible. Illegible plates and labels must be replaced.

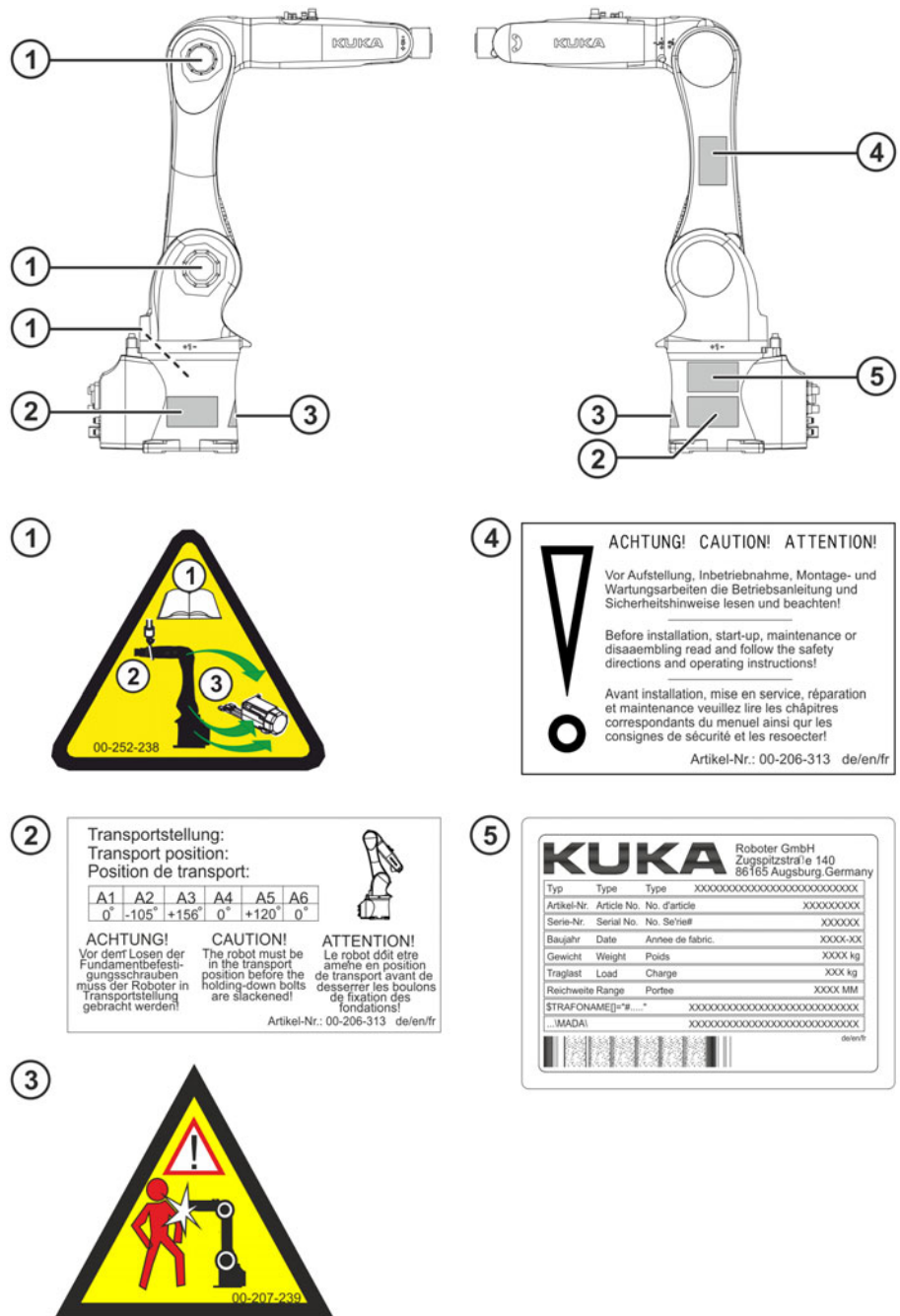

Fig. 4-34: Plates and labels

#### 4.10 Stopping distances and times

##### 4.10.1 General information

Information concerning the data:

- The stopping distance is the angle traveled by the robot from the moment the stop signal is triggered until the robot comes to a complete standstill.
- The stopping time is the time that elapses from the moment the stop signal is triggered until the robot comes to a complete standstill.
- The data are given for the main axes A1, A2 and A3. The main axes are the axes with the greatest deflection.
- Superposed axis motions can result in longer stopping distances.

- Stopping distances and stopping times in accordance with DIN EN ISO 10218-1, Annex B.
- Stop categories:
  - Stop category 0 » STOP 0
  - Stop category 1 » STOP 1 according to IEC 60204-1
- The values specified for Stop 0 are guide values determined by means of tests and simulation. They are average values which conform to the requirements of DIN EN ISO 10218-1. The actual stopping distances and stopping times may differ due to internal and external influences on the braking torque. It is therefore advisable to determine the exact stopping distances and stopping times where necessary under the real conditions of the actual robot application.
- Measuring technique  
The stopping distances were measured using the robot-internal measuring technique.
- The wear on the brakes varies depending on the operating mode, robot application and the number of STOP 0 triggered. It is therefore advisable to check the stopping distance at least once a year.

#### 4.10.2 Terms used

Term	Description
m	Mass of the rated load and the supplementary load on the arm.
Phi	Angle of rotation (°) about the corresponding axis. This value can be entered in the controller via the KCP and is displayed on the KCP.
POV	Program override (%) = velocity of the robot motion. This value can be entered in the controller via the KCP and is displayed on the KCP.
Extension	Distance (l in %) (>>> Fig. 4-35 ) between axis 1 and the intersection of axes 4 and 5. With parallelogram robots, the distance between axis 1 and the intersection of axis 6 and the mounting flange.
KCP	The KCP teach pendant has all the operator control and display functions required for operating and programming the robot system.

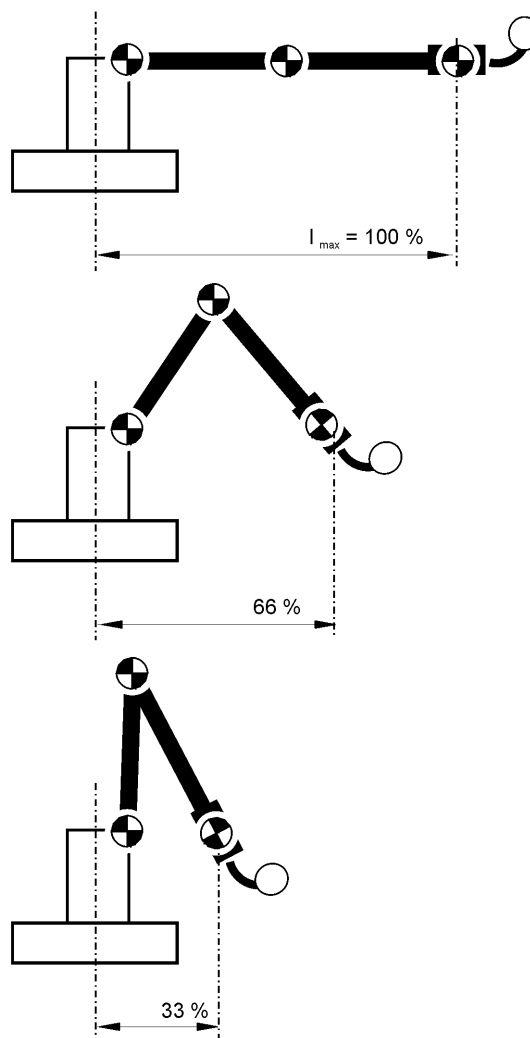

Fig. 4-35: Extension

#### 4.10.3 Stopping distances and times, KR 6 R700 sixx and KR 6 R700 sixx C

The following values are preliminary values and are valid for the following robots.

- KR 6 R700 sixx
- KR 6 R700 sixx C

##### 4.10.3.1 Stopping distances and stopping times for STOP 0, axis 1 to axis 3

The table shows the stopping distances and stopping times after a STOP 0 (category 0 stop) is triggered. The values refer to the following configuration:

- Extension  $I = 100\%$
- Program override  $POV = 100\%$
- Mass  $m =$  maximum load (rated load + supplementary load on arm)

	Stopping distance (°)	Stopping time (s)
Axis 1	133.67	0.494
Axis 2	122.43	0.556
Axis 3	79.29	0.371

## 4.10.3.2 Stopping distances and stopping times for STOP 1, axis 1

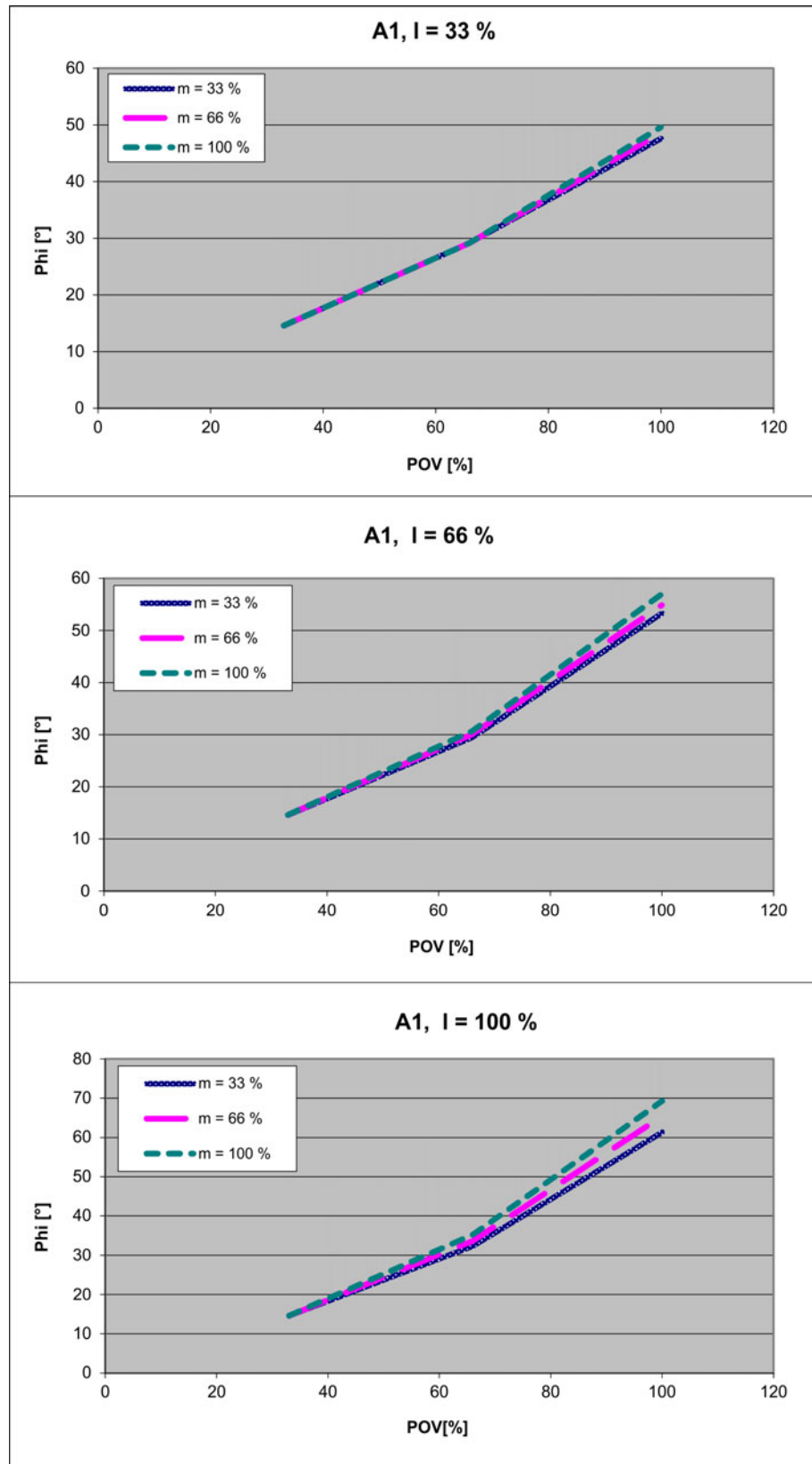

Fig. 4-36: Stopping distances for STOP 1, axis 1

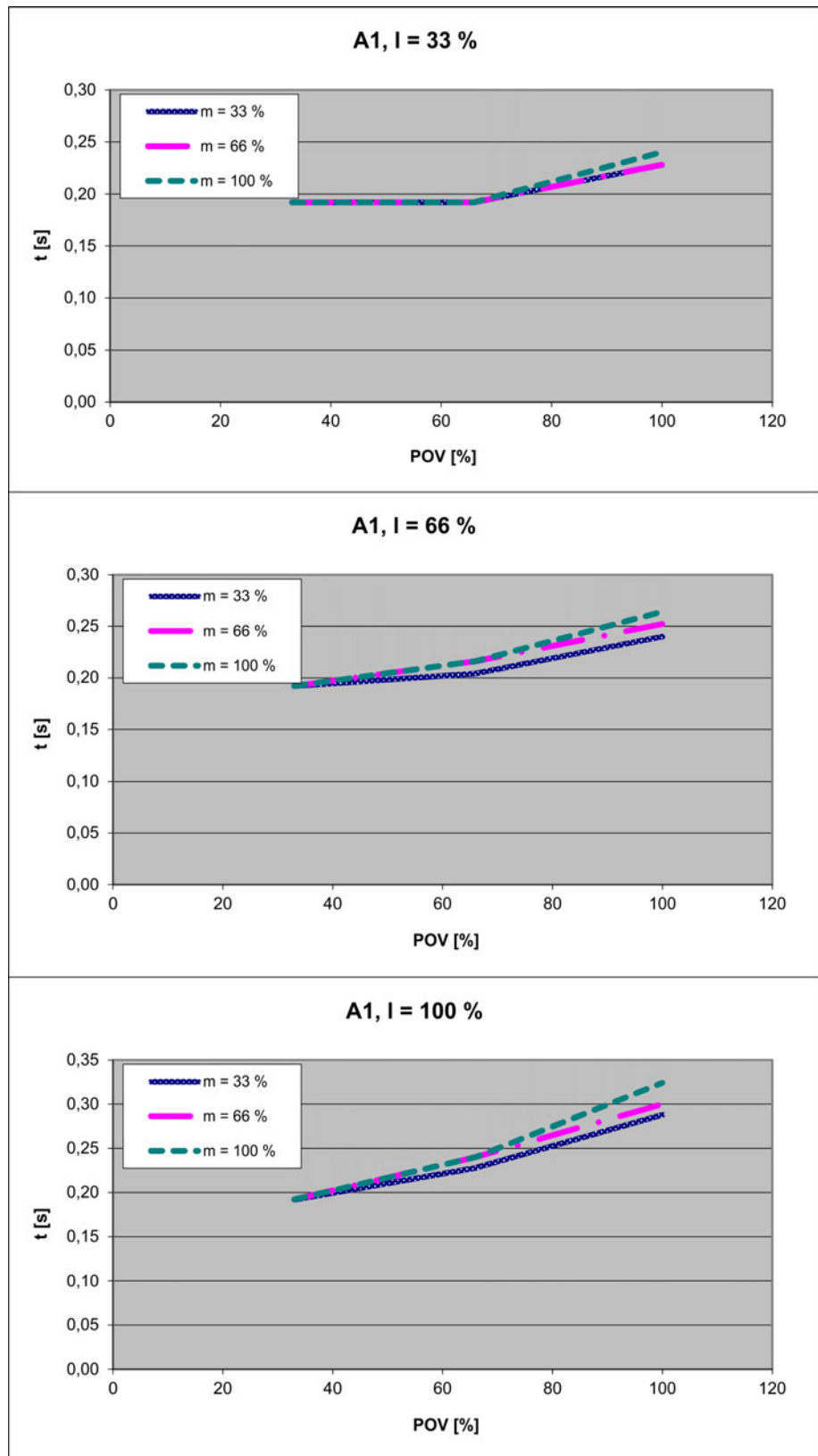
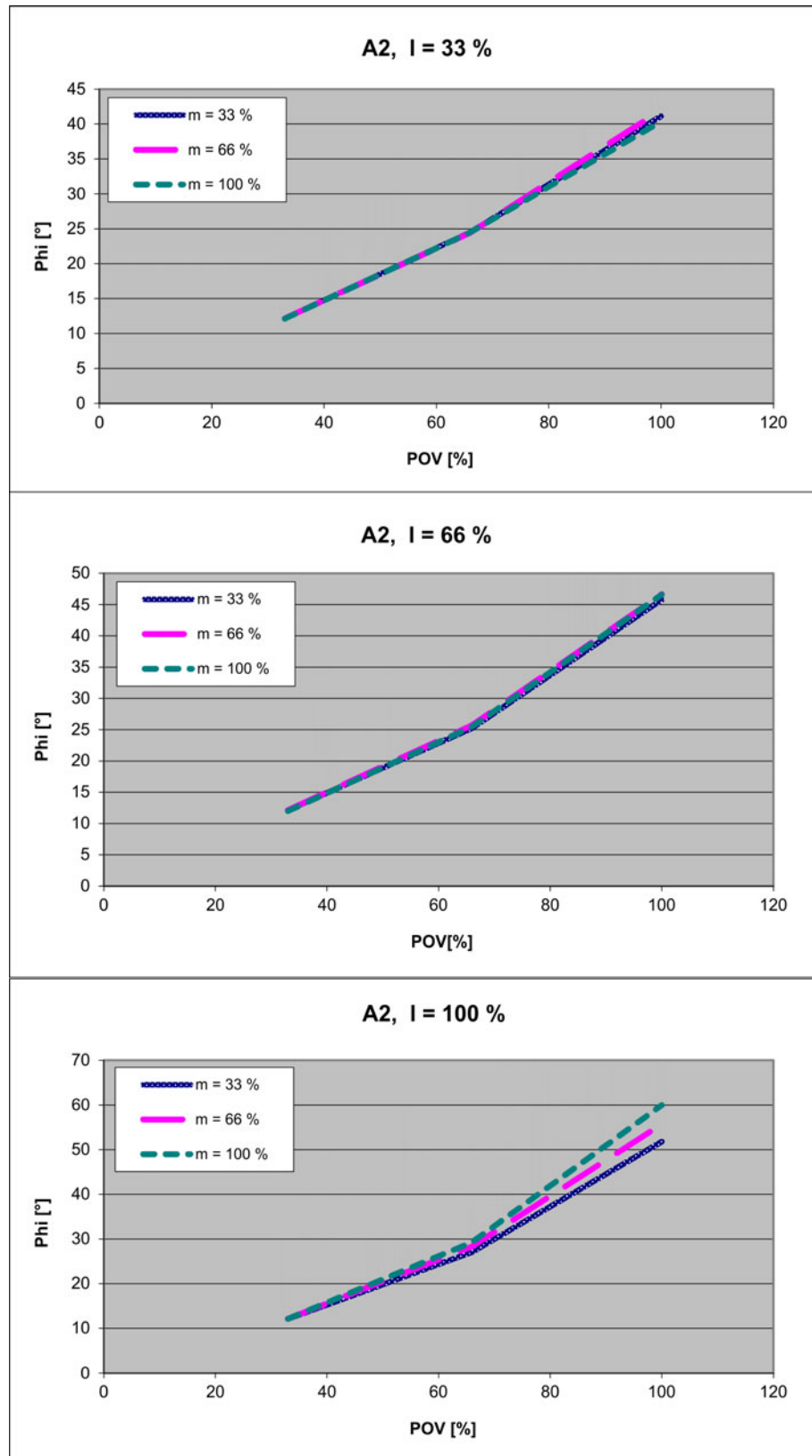

Fig. 4-37: Stopping times for STOP 1, axis 1



## 4.10.3.3 Stopping distances and stopping times for STOP 1, axis 2



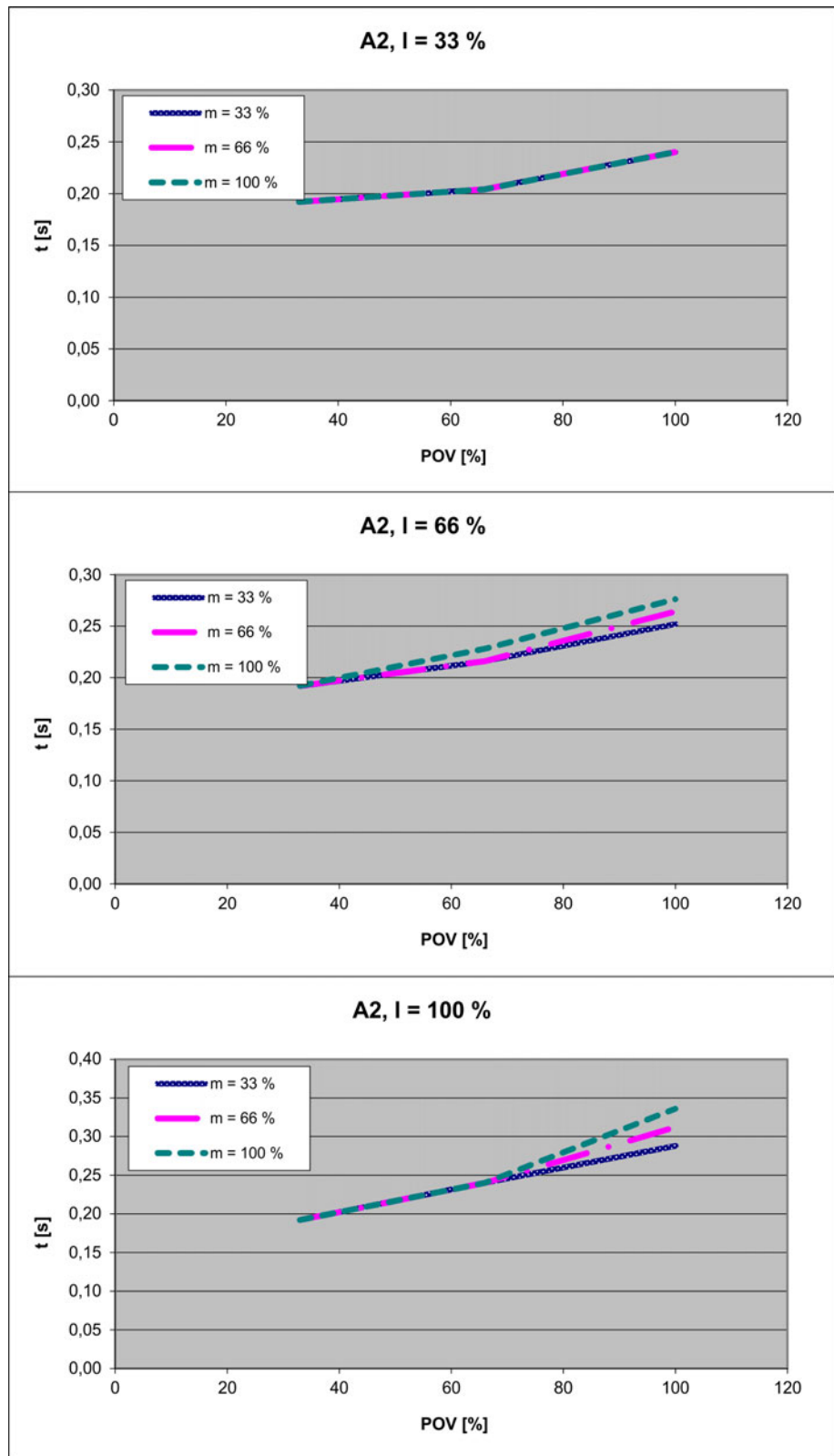
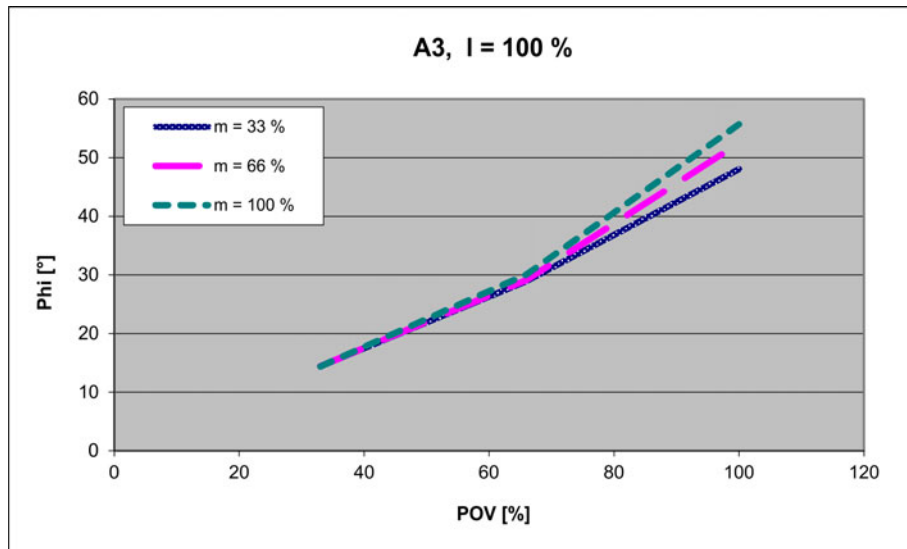
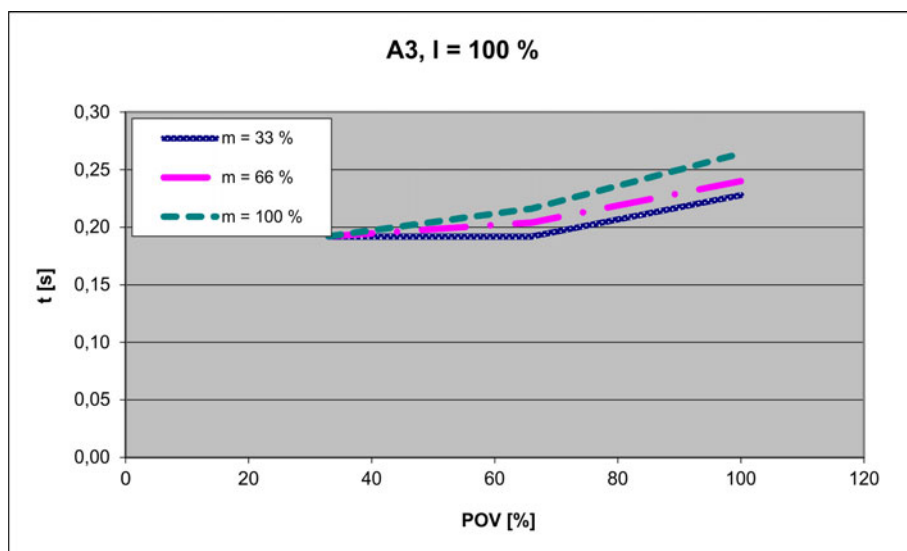

Fig. 4-39: Stopping times for STOP 1, axis 2

#### 4.10.3.4 Stopping distances and stopping times for STOP 1, axis 3



**Fig. 4-40: Stopping distances for STOP 1, axis 3**



**Fig. 4-41: Stopping times for STOP 1, axis 3**

#### 4.10.4 Stopping distances and times, KR 6 R700 sixx W

The following values are preliminary values and are valid for the following robots.

- KR 6 R700 sixx W

##### 4.10.4.1 Stopping distances and stopping times for STOP 0, axis 1 to axis 3

The table shows the stopping distances and stopping times after a STOP 0 (category 0 stop) is triggered. The values refer to the following configuration:

- Extension l = 100%
- Program override POV = 100%
- Mass m = maximum load (rated load + supplementary load on arm)

	Stopping distance (°)	Stopping time (s)
Axis 1	182.04	0.665
Axis 2	68.31	0.377
Axis 3	63.48	0.379

4.10.4.2 Stopping distances and stopping times for STOP 1, axis 1

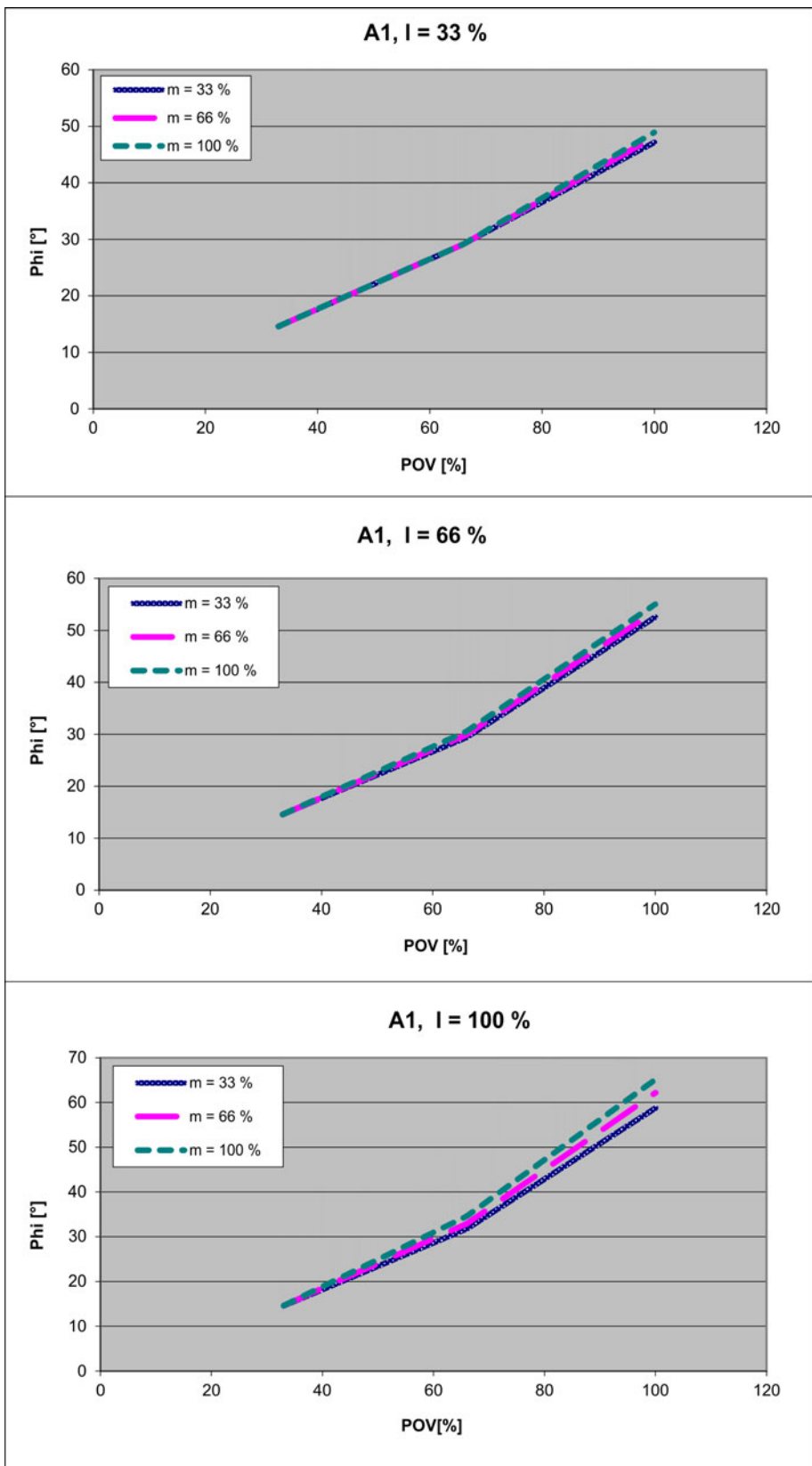

Fig. 4-42: Stopping distances for STOP 1, axis 1

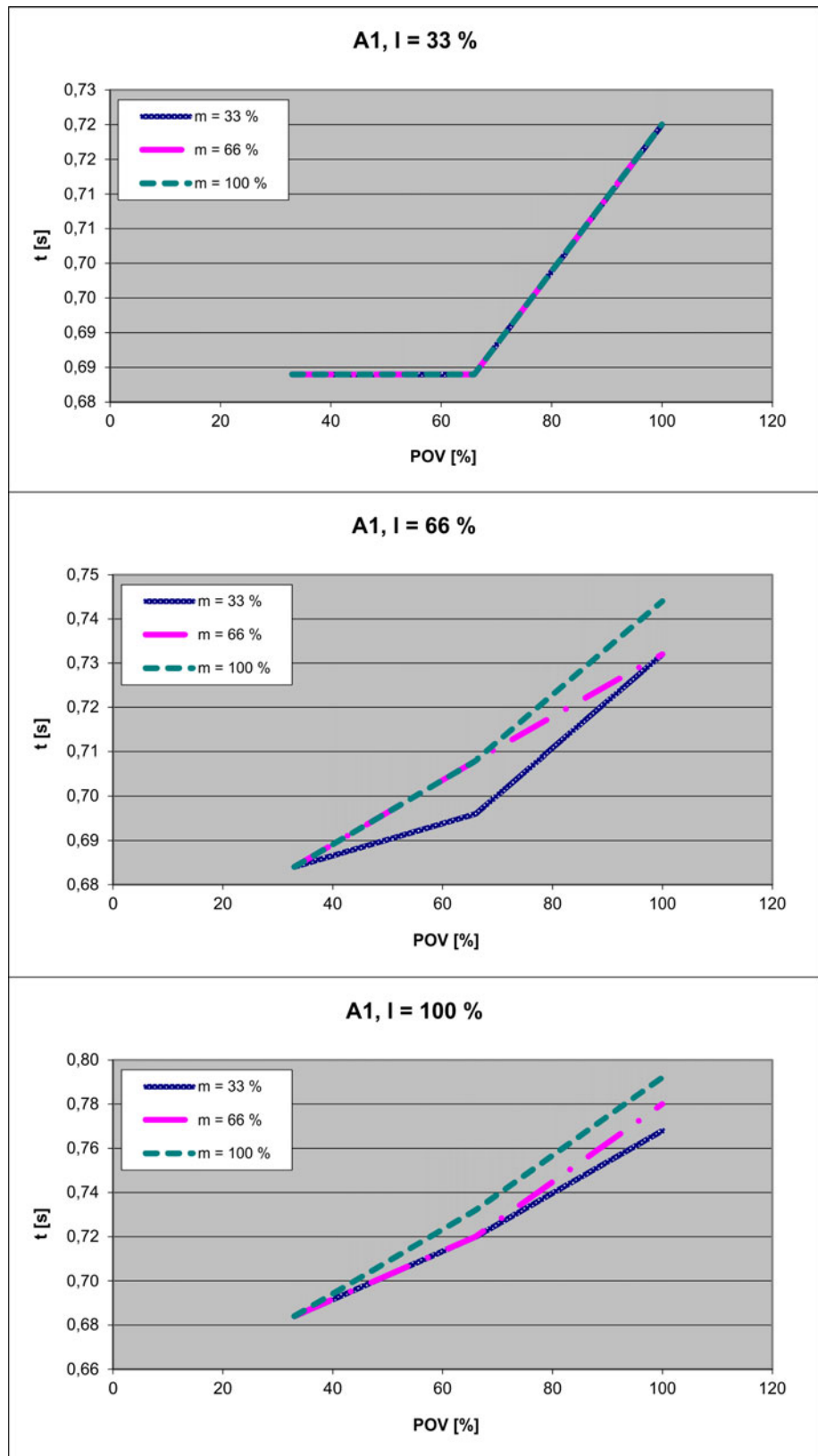

Fig. 4-43: Stopping times for STOP 1, axis 1

## 4.10.4.3 Stopping distances and stopping times for STOP 1, axis 2

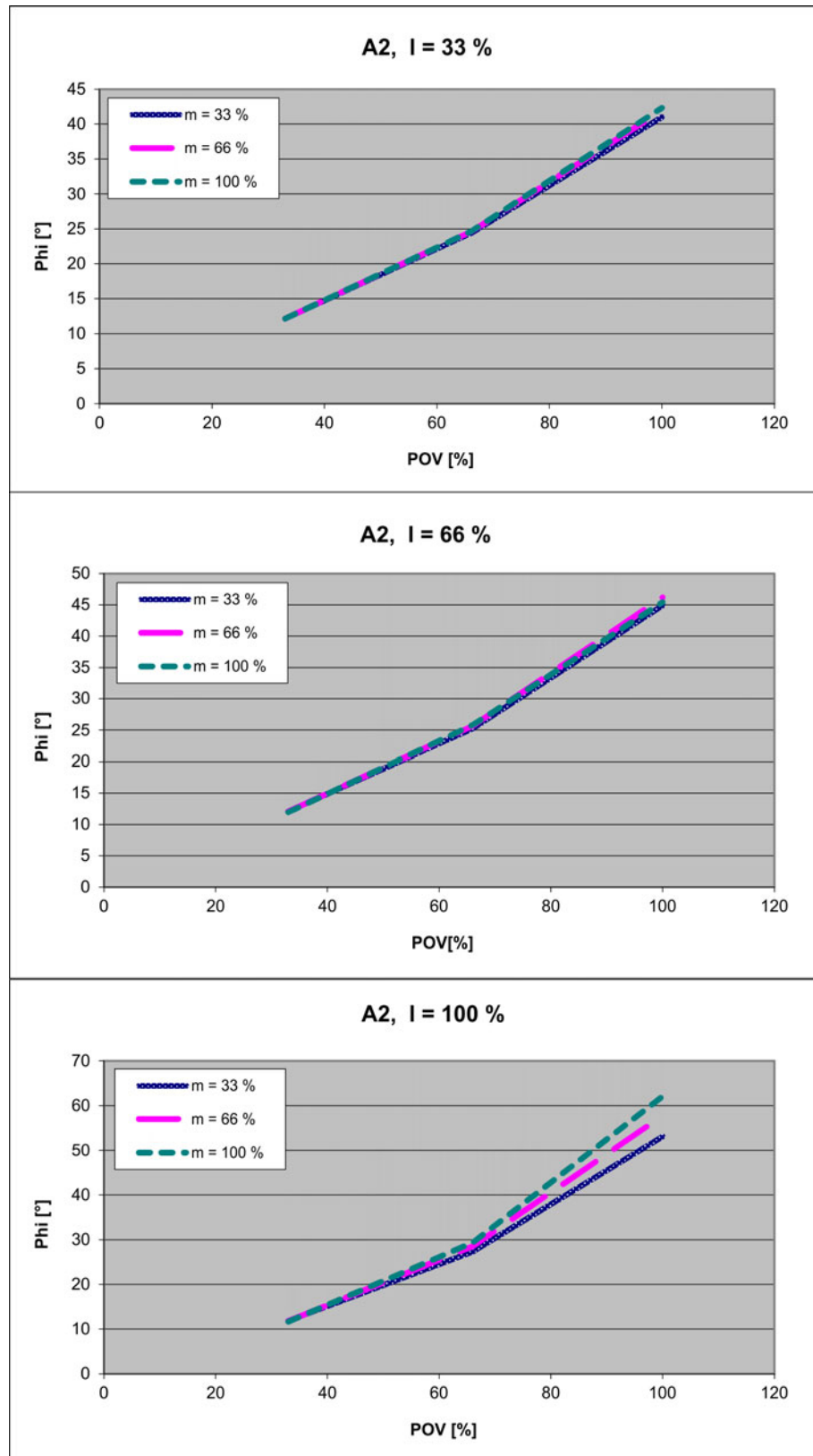

Fig. 4-44: Stopping distances for STOP 1, axis 1

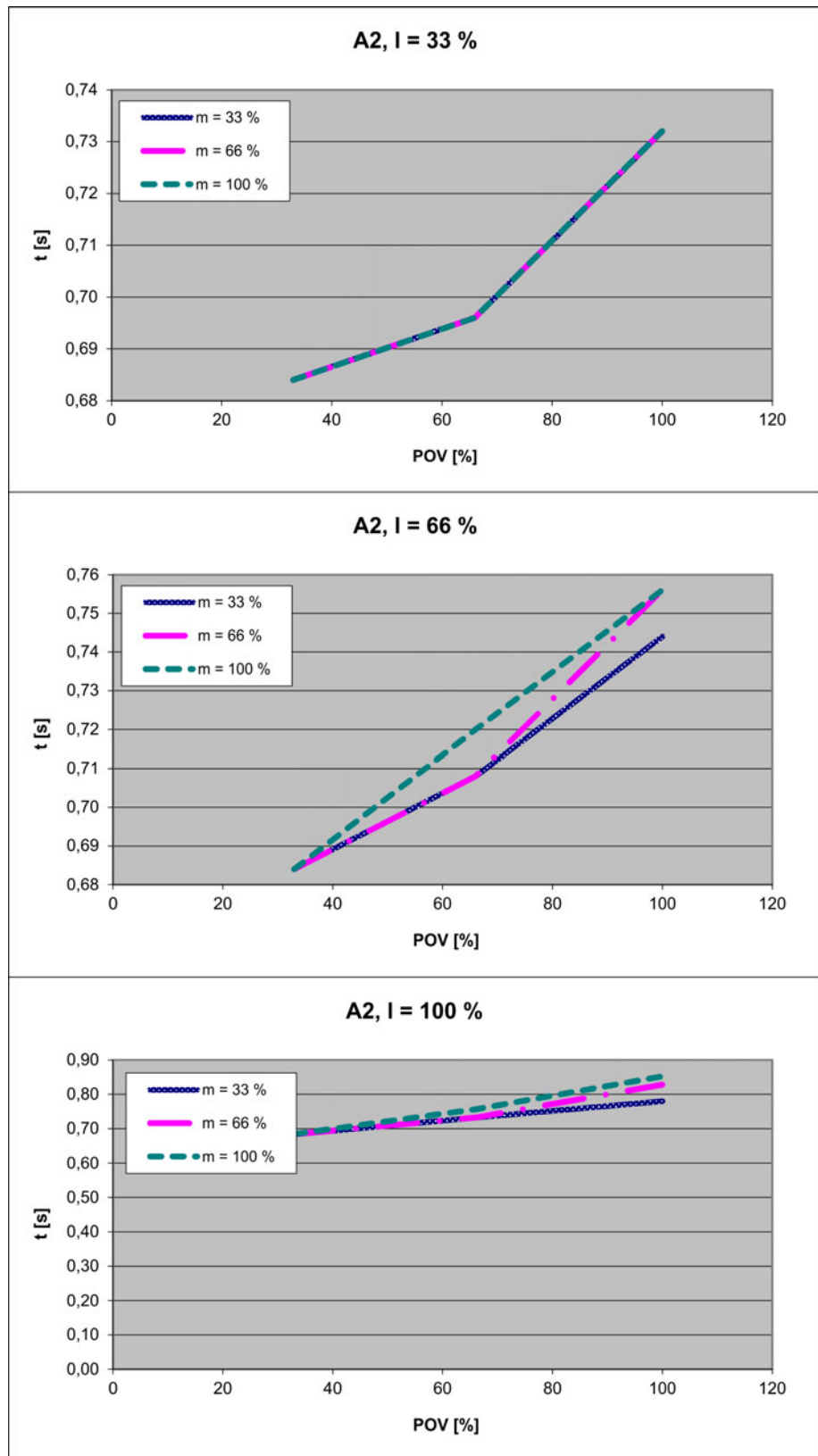

Fig. 4-45: Stopping times for STOP 1, axis 1



#### 4.10.4.4 Stopping distances and stopping times for STOP 1, axis 2

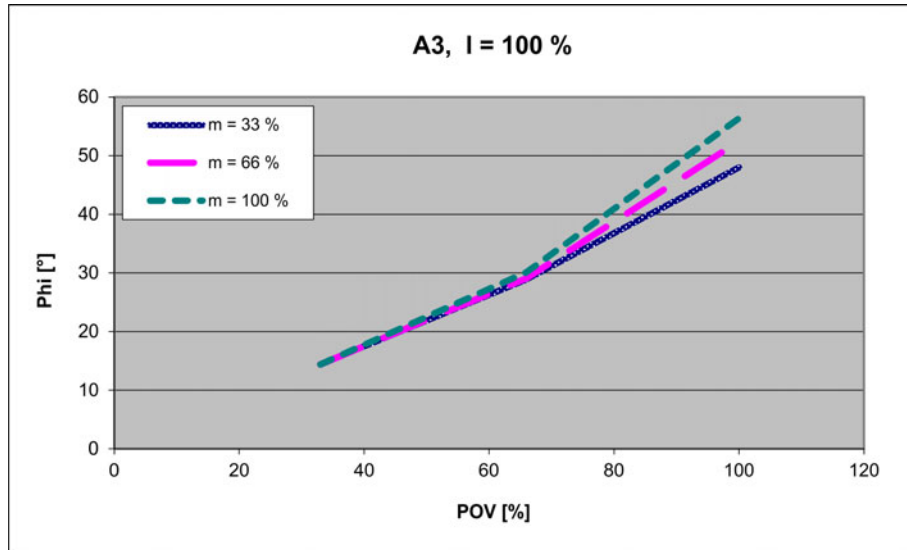

Fig. 4-46: Stopping distances for STOP 1, axis 1

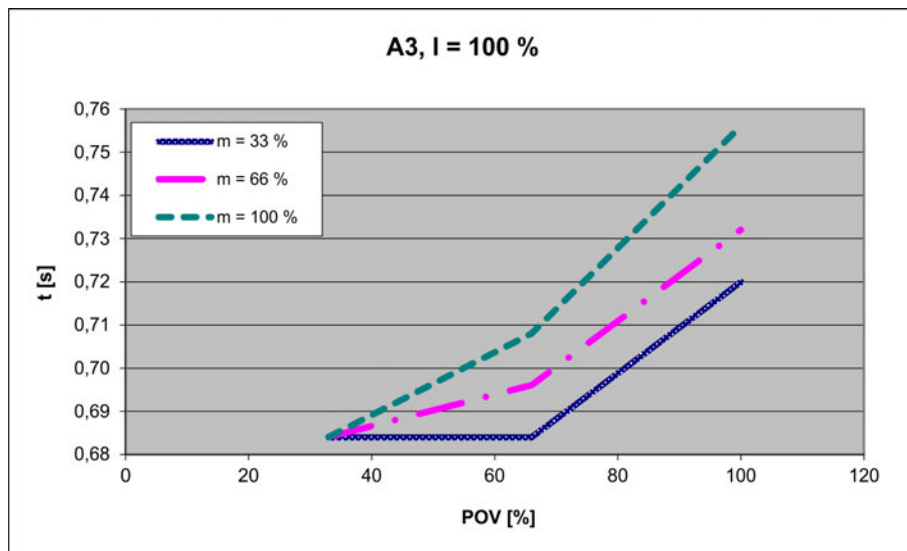

Fig. 4-47: Stopping times for STOP 1, axis 1

#### 4.10.5 Stopping distances and times, KR 6 R900 sixx and KR 6 R900 sixx C

The following values are valid for the following robots:

- KR 6 R900 sixx
- KR 6 R900 sixx C

##### 4.10.5.1 Stopping distances and stopping times for STOP 0, axis 1 to axis 3

The table shows the stopping distances and stopping times after a STOP 0 (category 0 stop) is triggered. The values refer to the following configuration:

- Extension I = 100%
- Program override POV = 100%
- Mass m = maximum load (rated load + supplementary load on arm)

	<b>Stopping distance (°)</b>	<b>Stopping time (s)</b>
Axis 1	113.59	0.507
Axis 2	126.76	0.684
Axis 3	68.10	0.370

## 4.10.5.2 Stopping distances and stopping times for STOP 1, axis 1

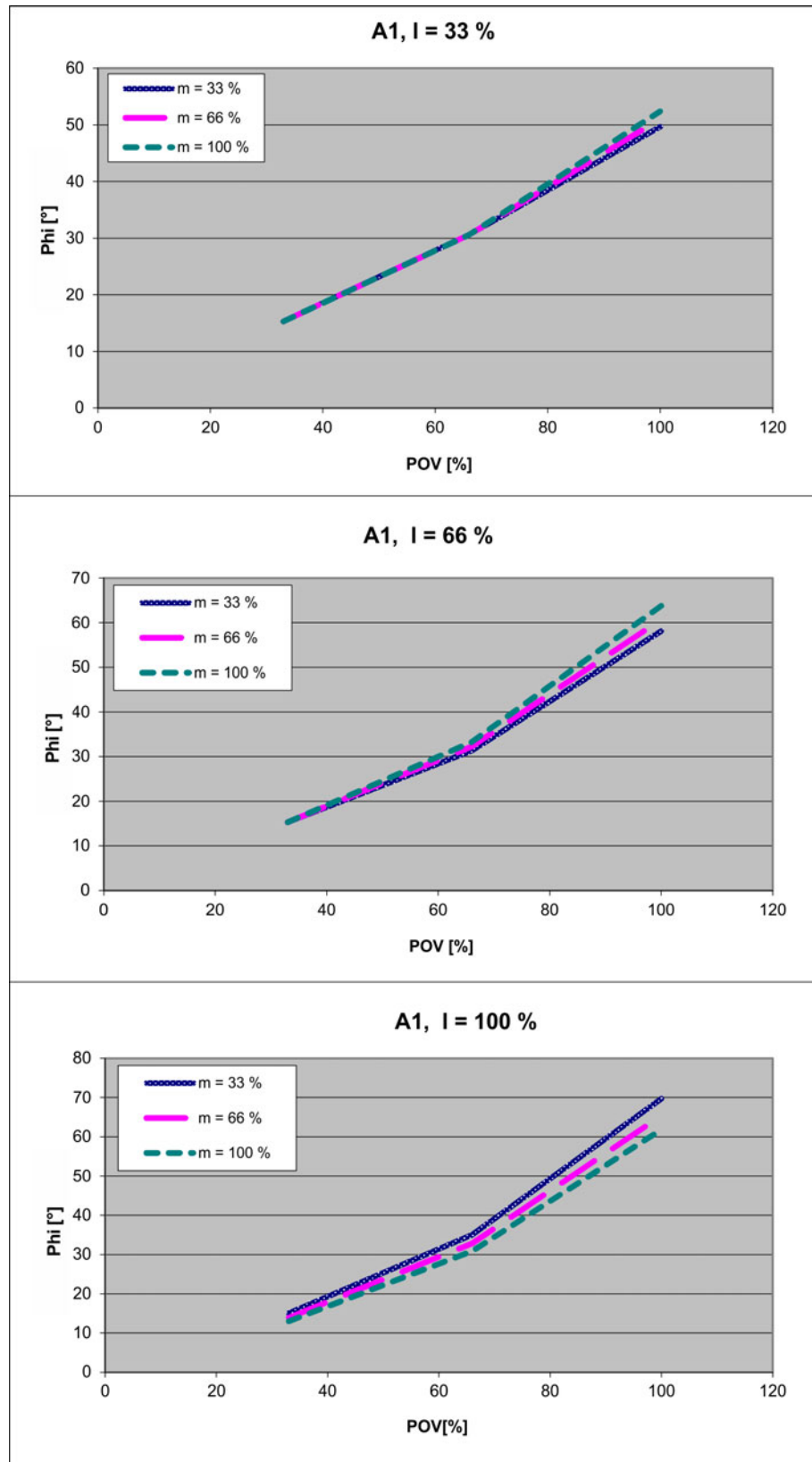

Fig. 4-48: Stopping distances for STOP 1, axis 1

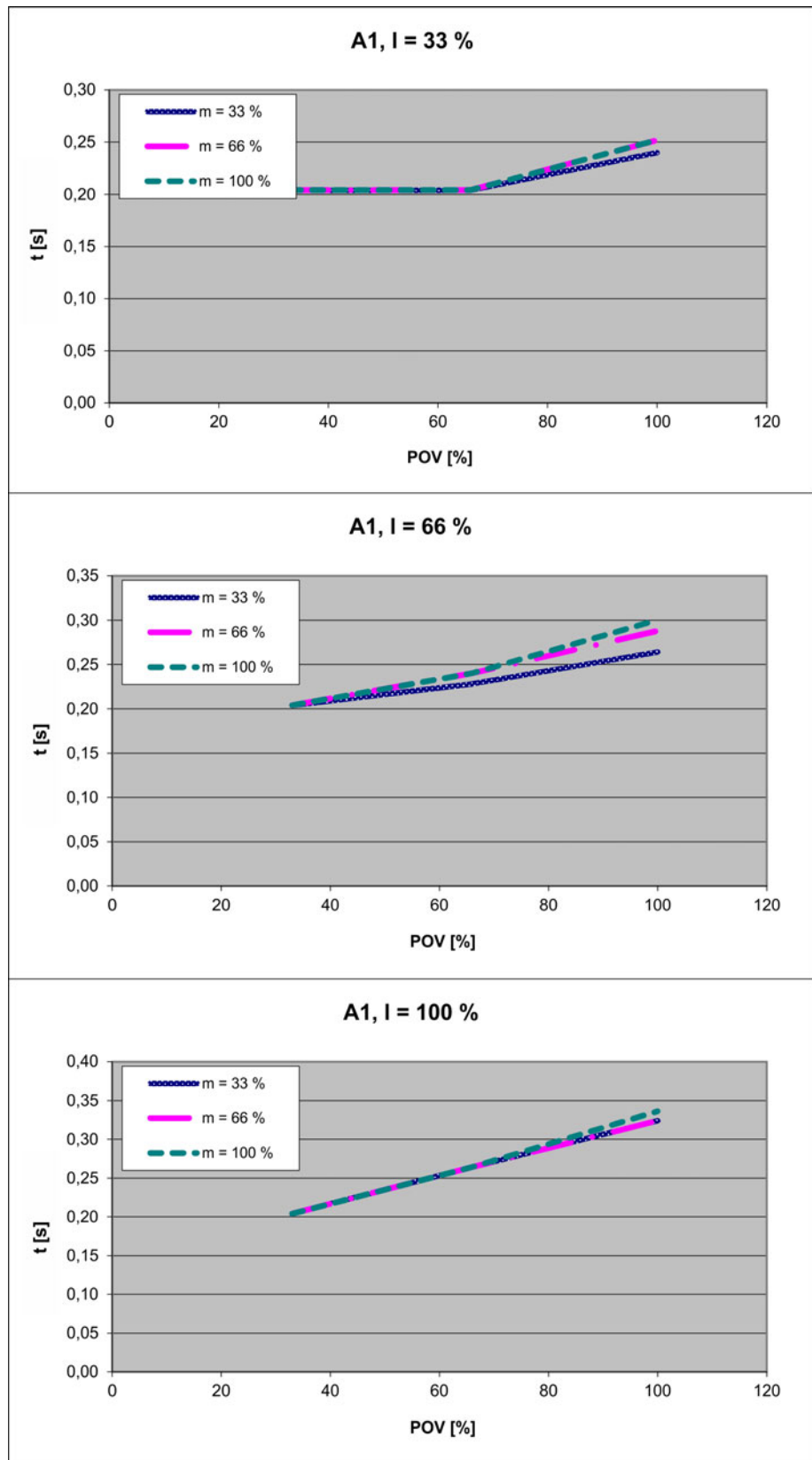

Fig. 4-49: Stopping times for STOP 1, axis 1

## 4.10.5.3 Stopping distances and stopping times for STOP 1, axis 2

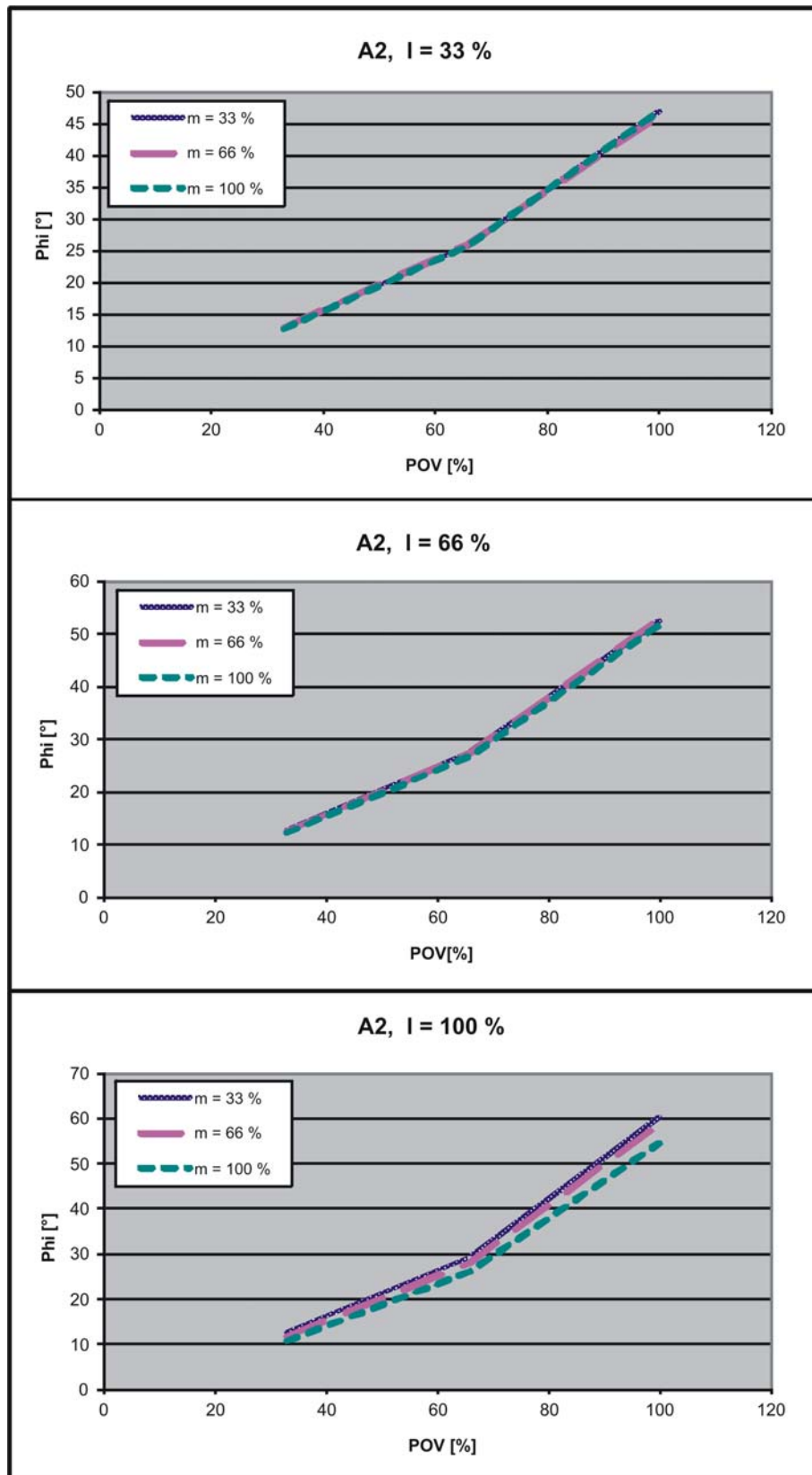

Fig. 4-50: Stopping distances for STOP 1, axis 2

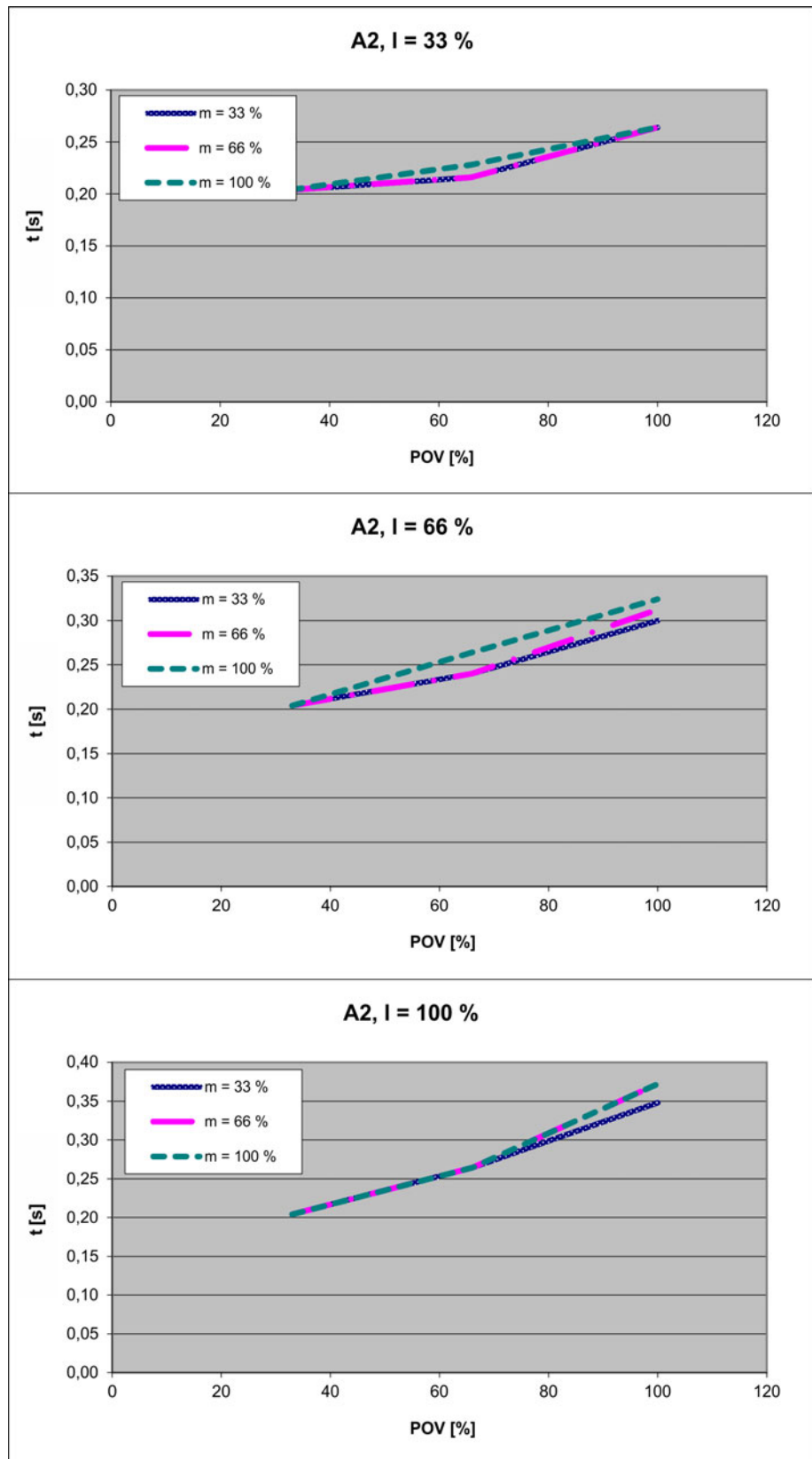

Fig. 4-51: Stopping times for STOP 1, axis 2

#### 4.10.5.4 Stopping distances and stopping times for STOP 1, axis 3

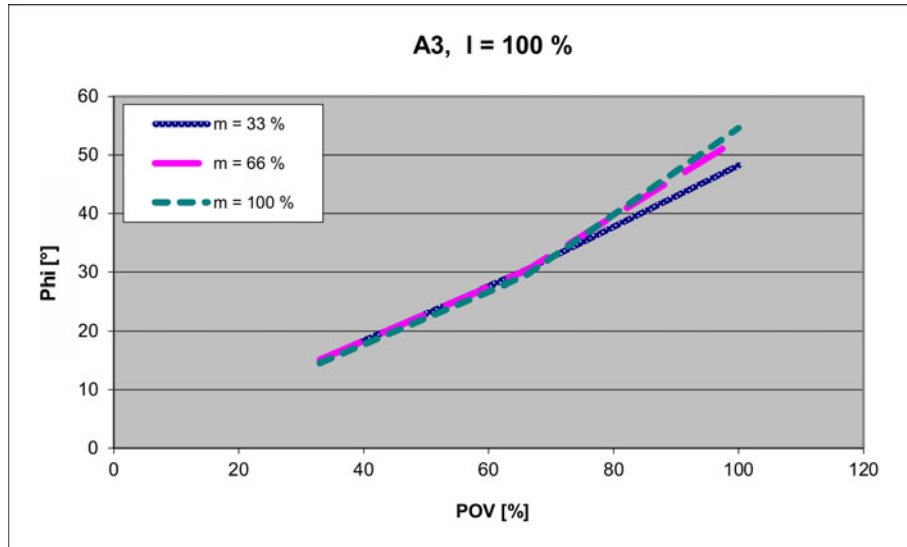

Fig. 4-52: Stopping distances for STOP 1, axis 3

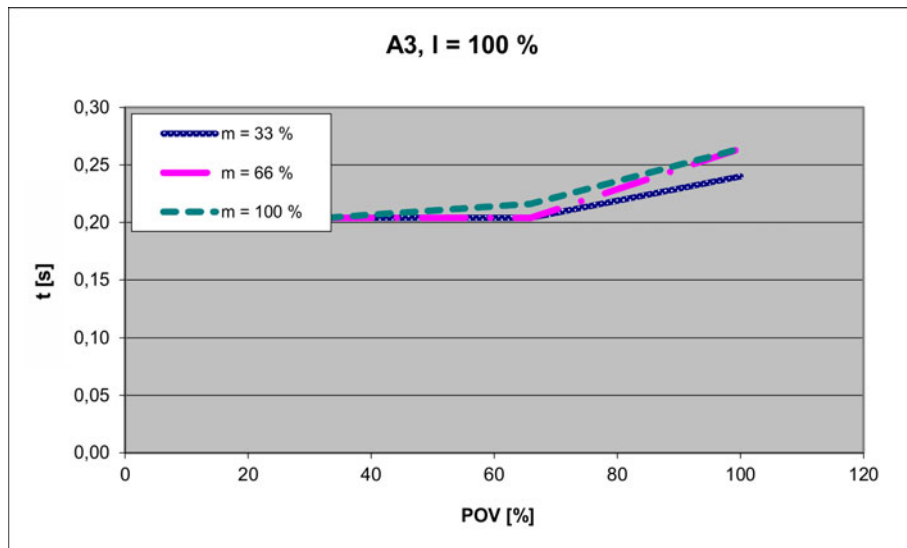

Fig. 4-53: Stopping times for STOP 1, axis 3

#### 4.10.6 Stopping distances and times, KR 6 R900 sixx W

The following values are valid for the following robots:

- KR 6 R900 sixx W

##### 4.10.6.1 Stopping distances and stopping times for STOP 0, axis 1 to axis 3

The table shows the stopping distances and stopping times after a STOP 0 (category 0 stop) is triggered. The values refer to the following configuration:

- Extension I = 100%
- Program override POV = 100%
- Mass m = maximum load (rated load + supplementary load on arm)

	Stopping distance (°)	Stopping time (s)
Axis 1	163.11	0.745
Axis 2	67.78	0.404
Axis 3	60.96	0.387



## 4.10.6.2 Stopping distances and stopping times for STOP 1, axis 1

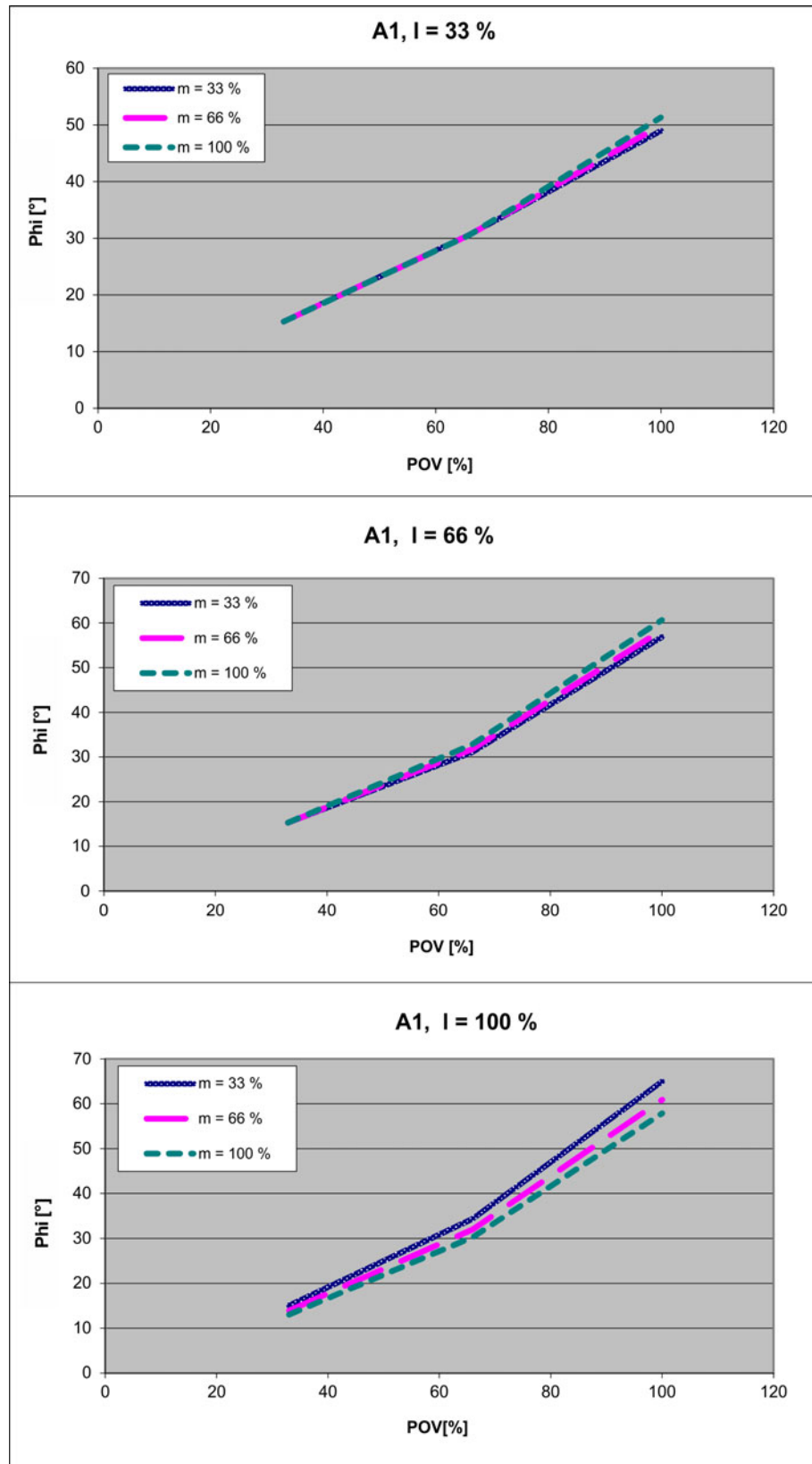

Fig. 4-54: Stopping distances for STOP 1, axis 1

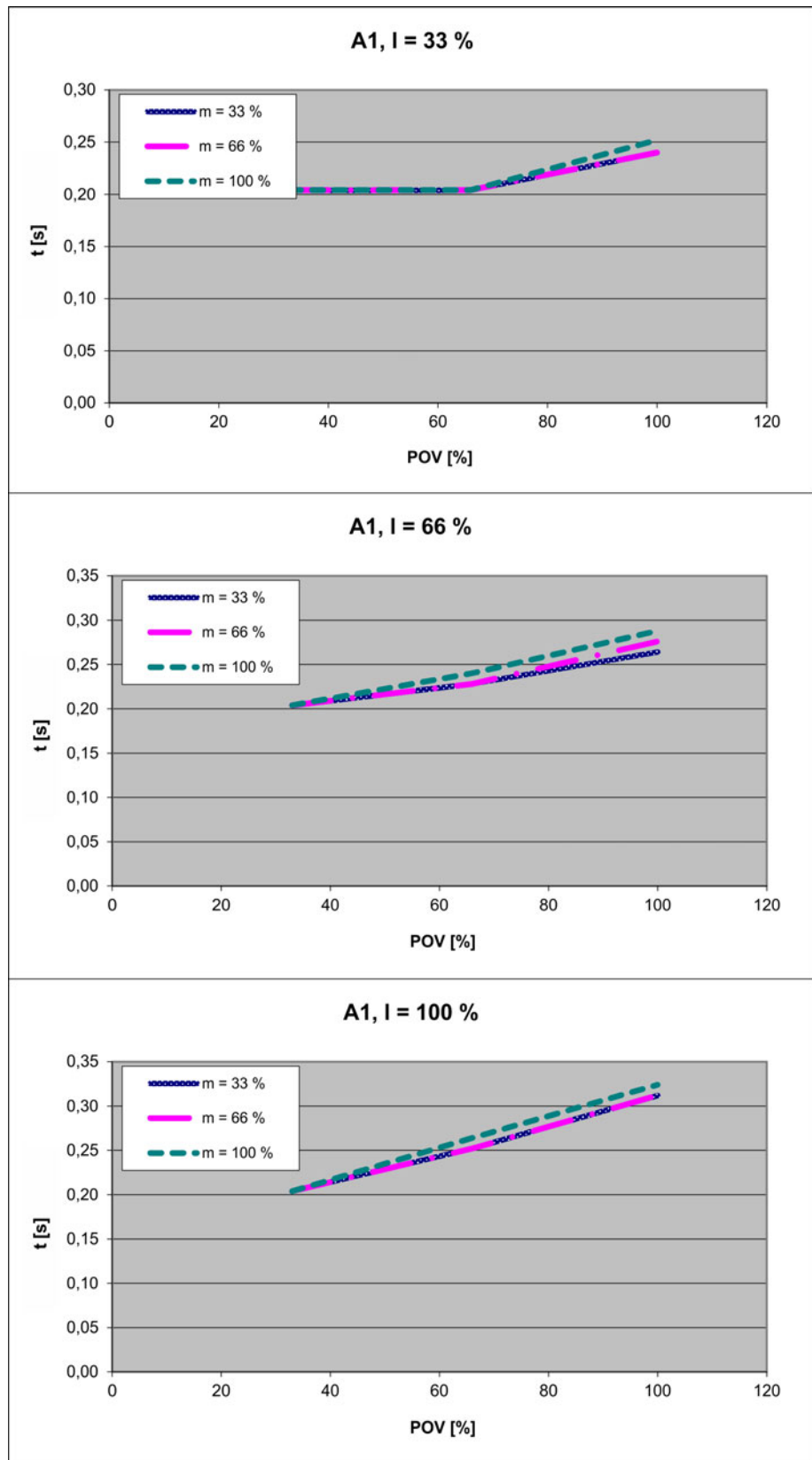
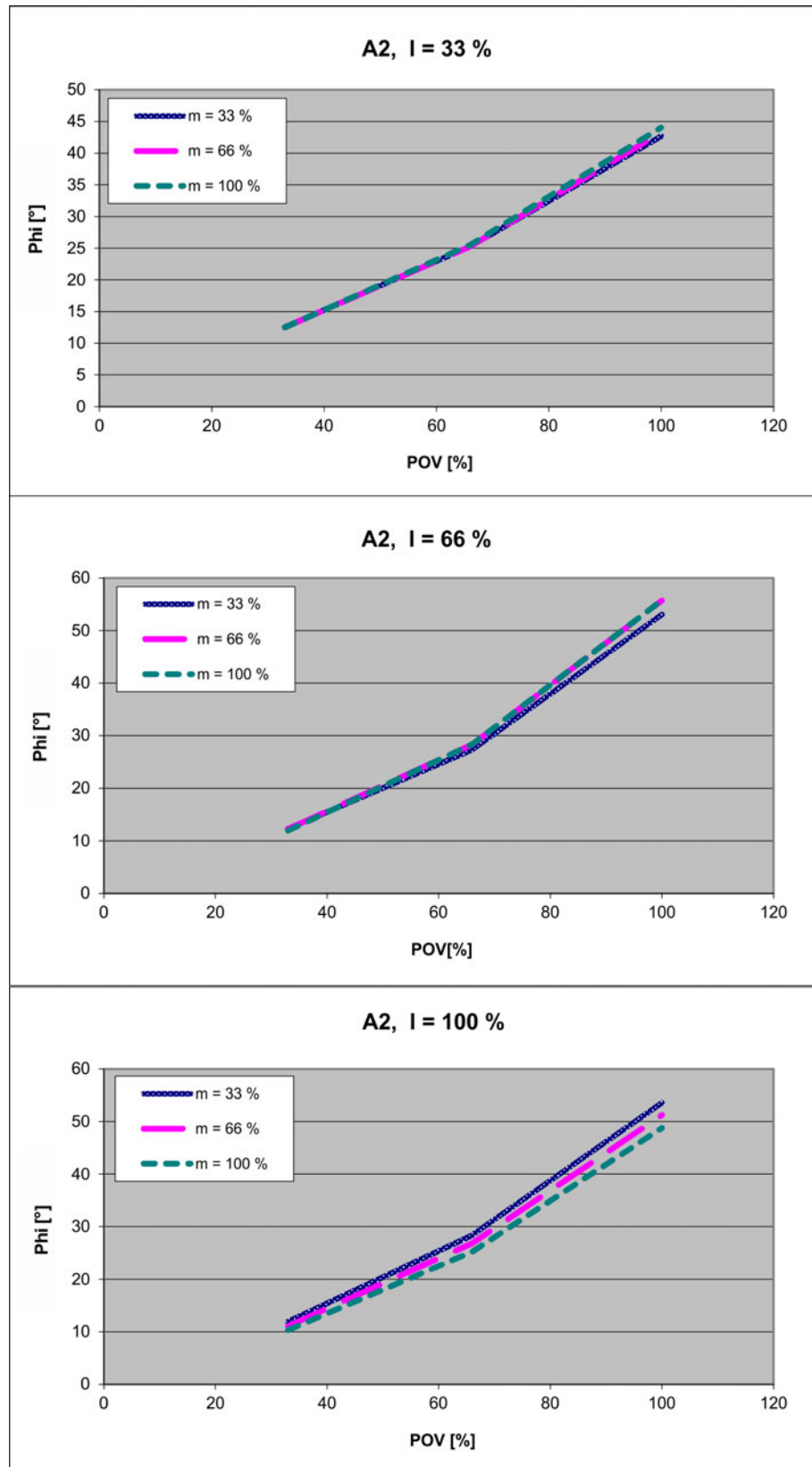

Fig. 4-55: Stopping times for STOP 1, axis 1

## 4.10.6.3 Stopping distances and stopping times for STOP 1, axis 2



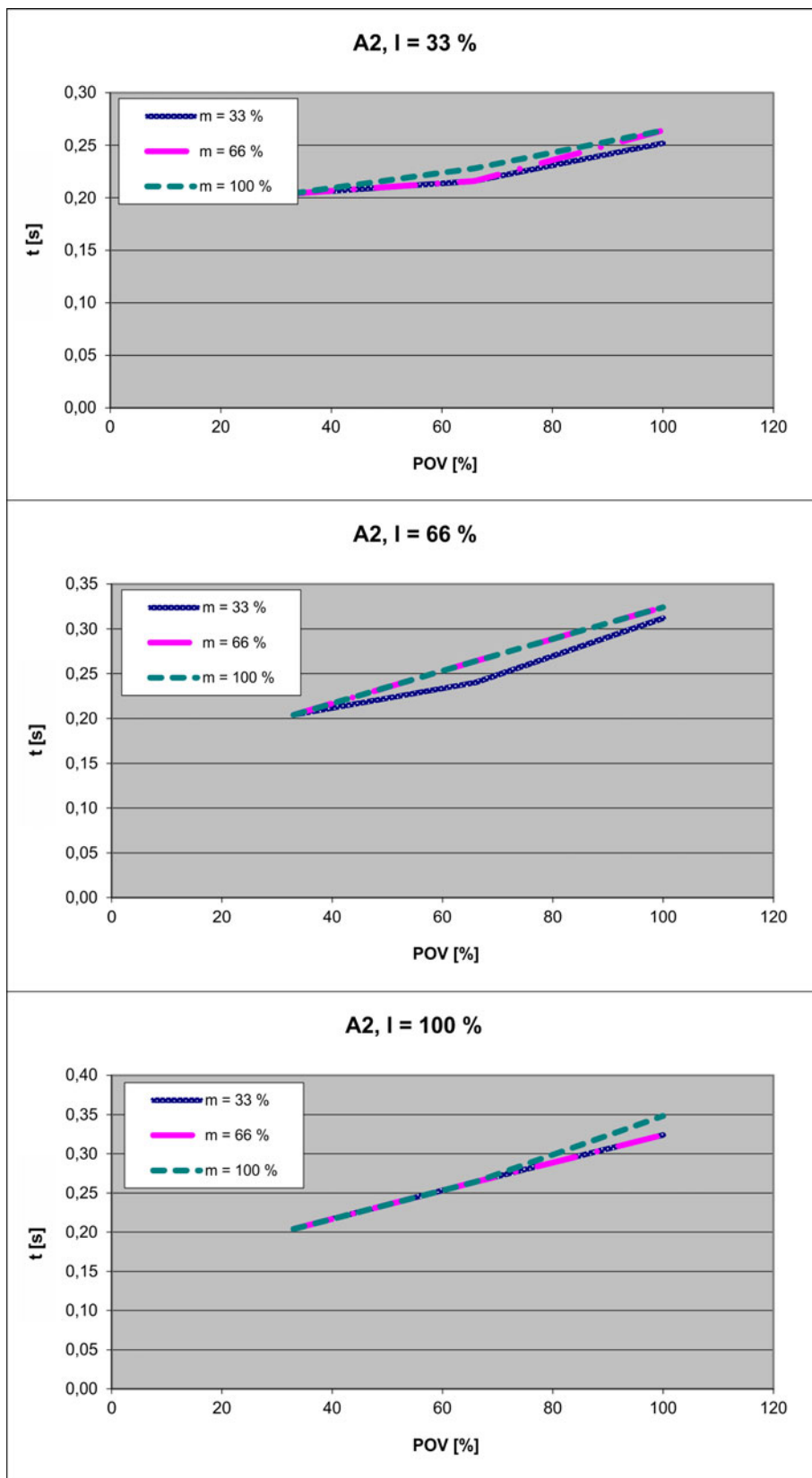
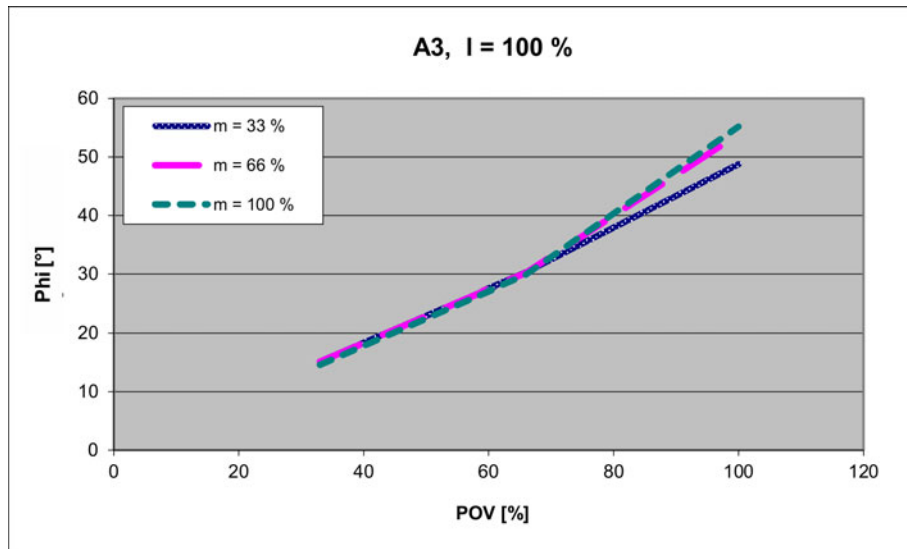
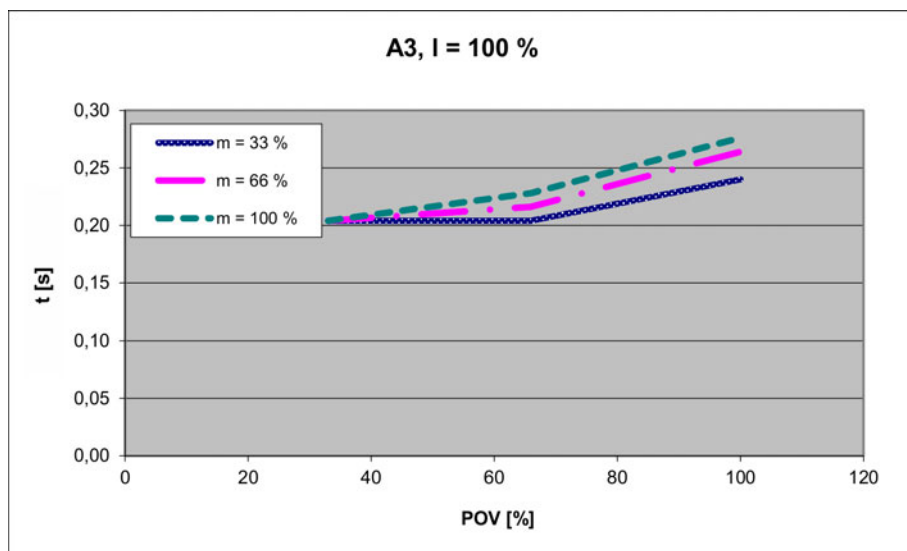

Fig. 4-57: Stopping times for STOP 1, axis 2

#### 4.10.6.4 Stopping distances and stopping times for STOP 1, axis 3



**Fig. 4-58: Stopping distances for STOP 1, axis 3**



**Fig. 4-59: Stopping times for STOP 1, axis 3**

#### 4.10.7 Stopping distances and times, KR 10 R900 sixx and KR 10 R1100 sixx

The following values are preliminary values and are valid for the following robots.

- KR 10 R900 sixx
- KR 10 R900 sixx C
- KR 10 R1100 sixx
- KR 10 R1100 sixx C

##### 4.10.7.1 Stopping distances and stopping times for STOP 0, axis 1 to axis 3

The table shows the stopping distances and stopping times after a STOP 0 (category 0 stop) is triggered. The values refer to the following configuration:

- Extension I = 100%
- Program override POV = 100%

- Mass  $m$  = maximum load (rated load + supplementary load on arm)

	Stopping distance (°)	Stopping time (s)
Axis 1	106.21	0.536
Axis 2	96.06	0.647
Axis 3	46.99	0.373

## 4.10.7.2 Stopping distances and stopping times for STOP 1, axis 1

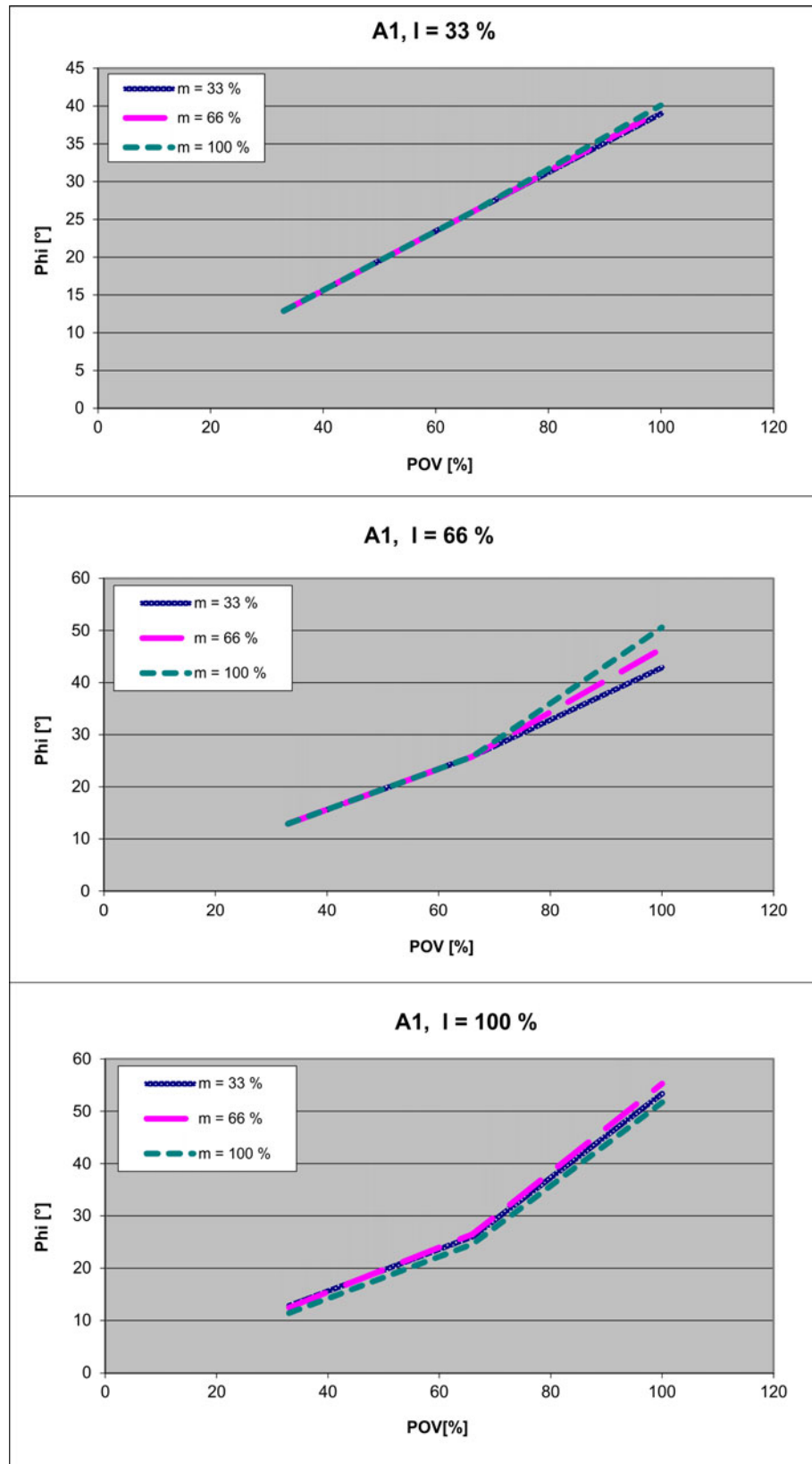

Fig. 4-60: Stopping distances for STOP 1, axis 1

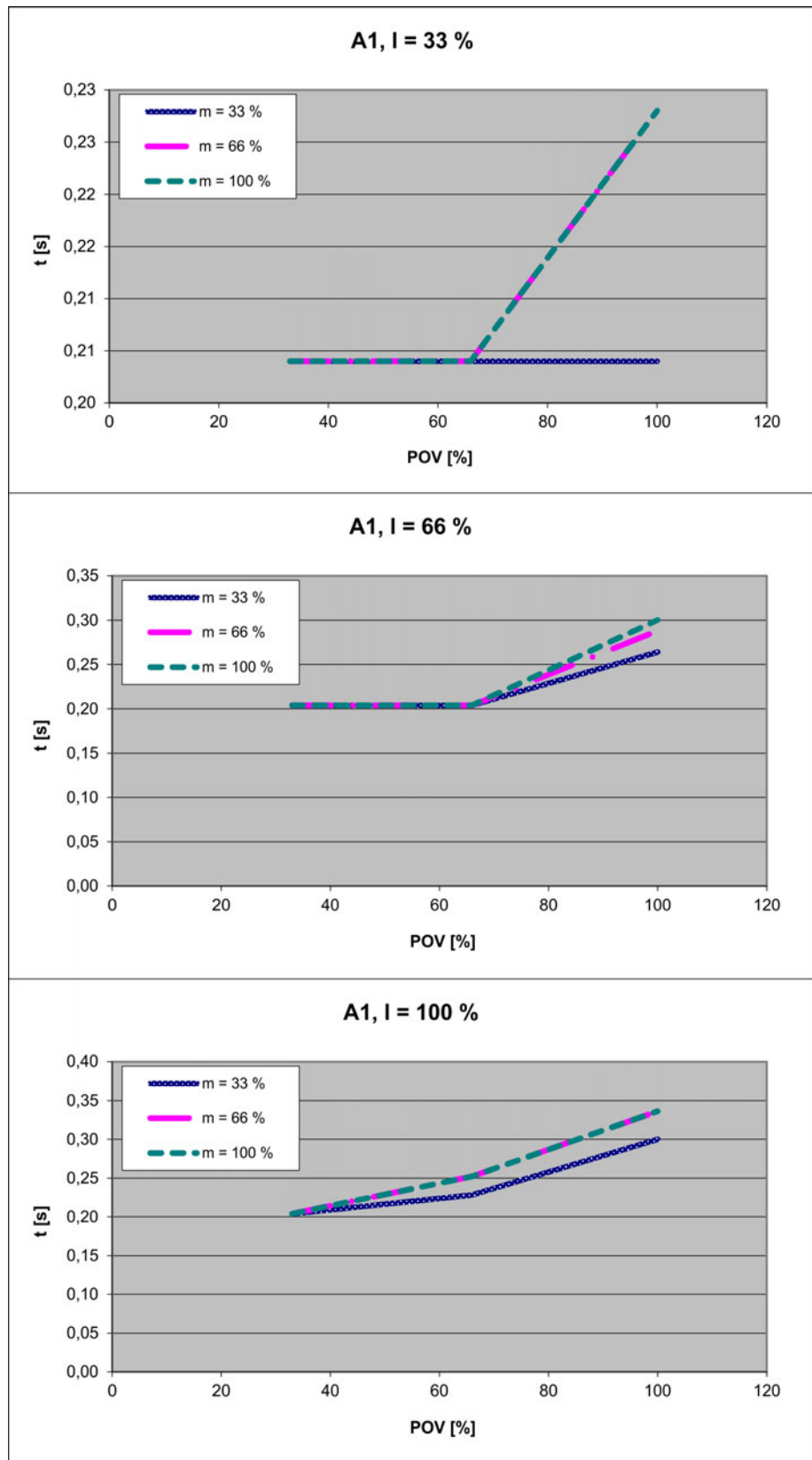

Fig. 4-61: Stopping times for STOP 1, axis 1



## 4.10.7.3 Stopping distances and stopping times for STOP 1, axis 2

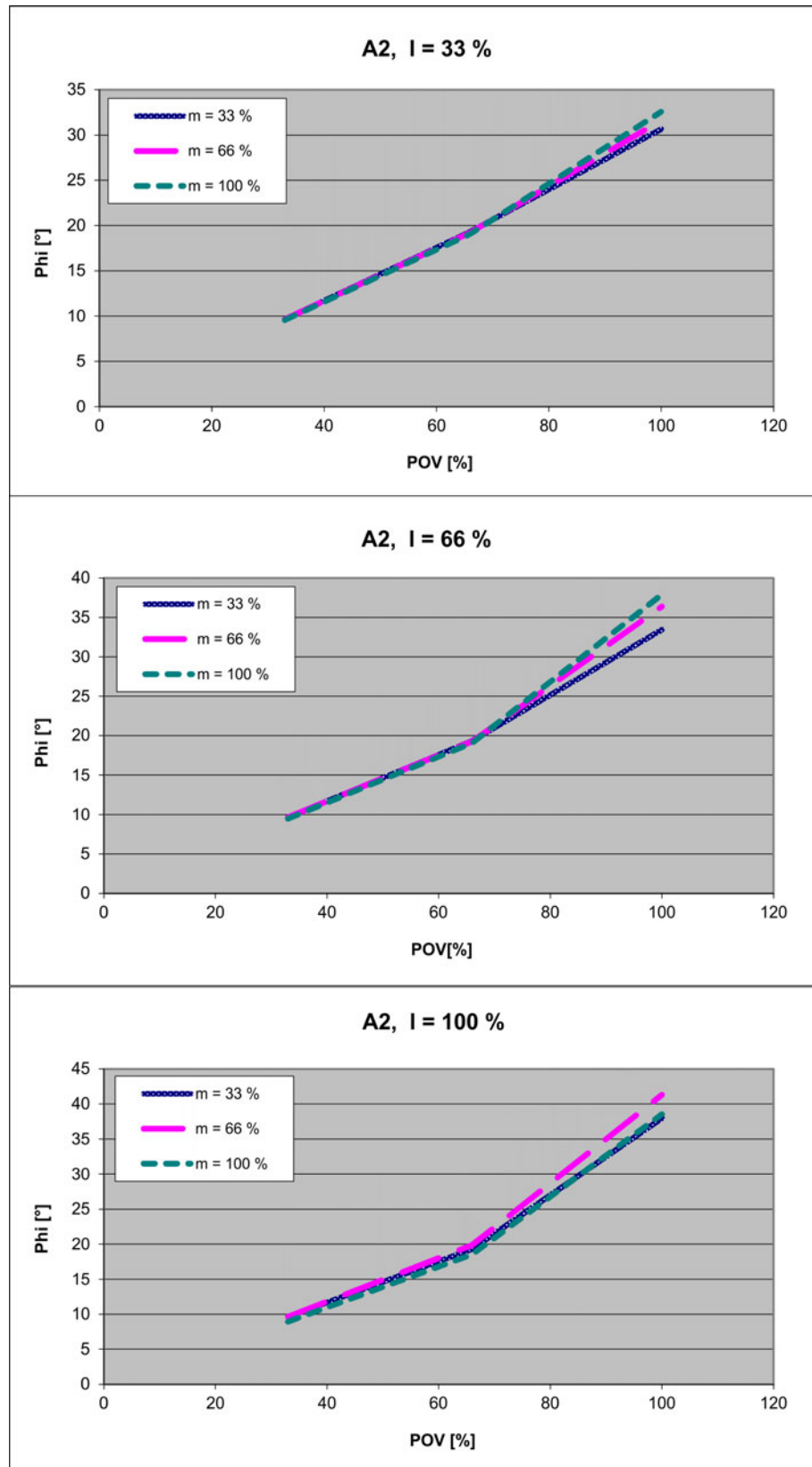

Fig. 4-62: Stopping distances for STOP 1, axis 2

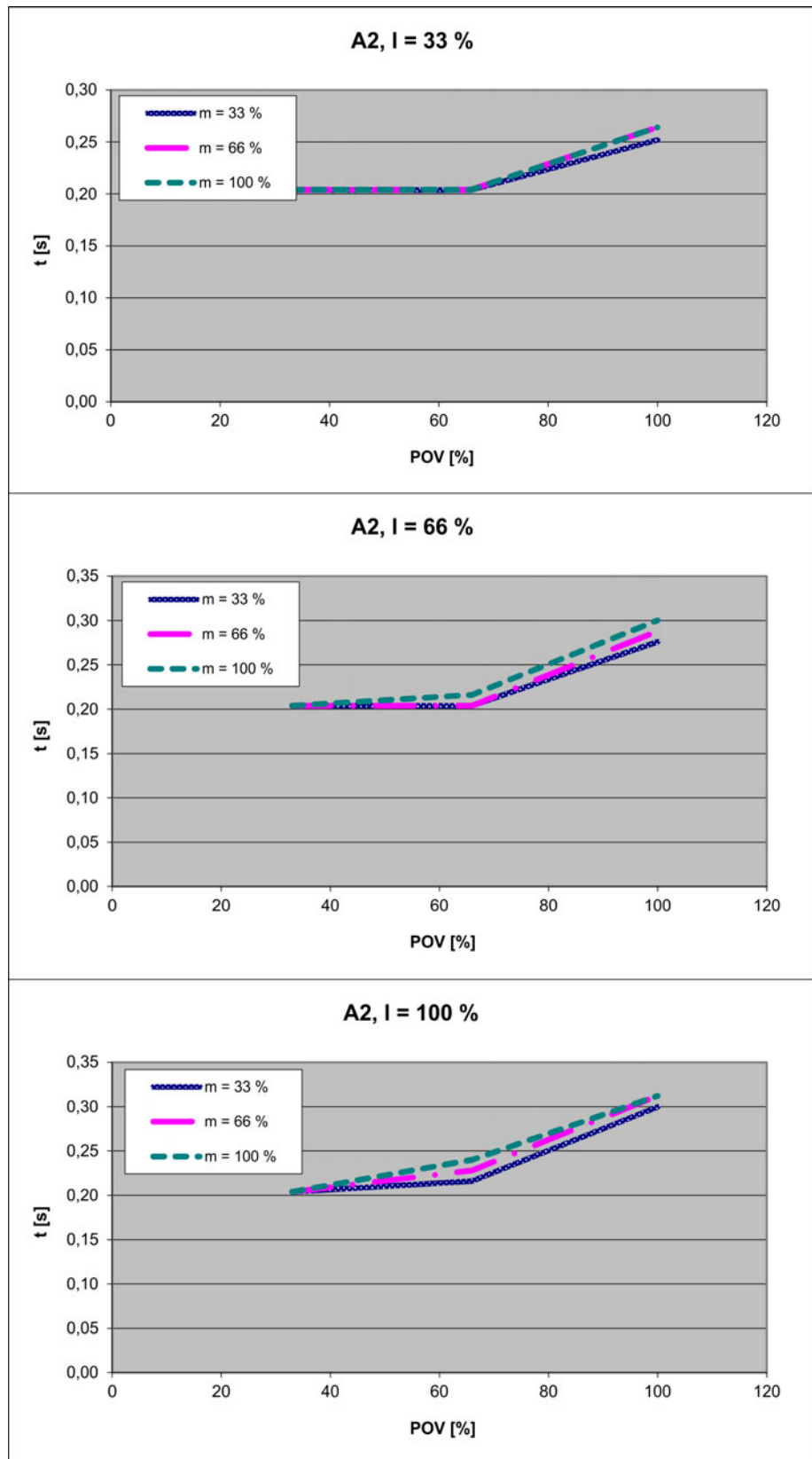

Fig. 4-63: Stopping times for STOP 1, axis 2

#### 4.10.7.4 Stopping distances and stopping times for STOP 1, axis 3

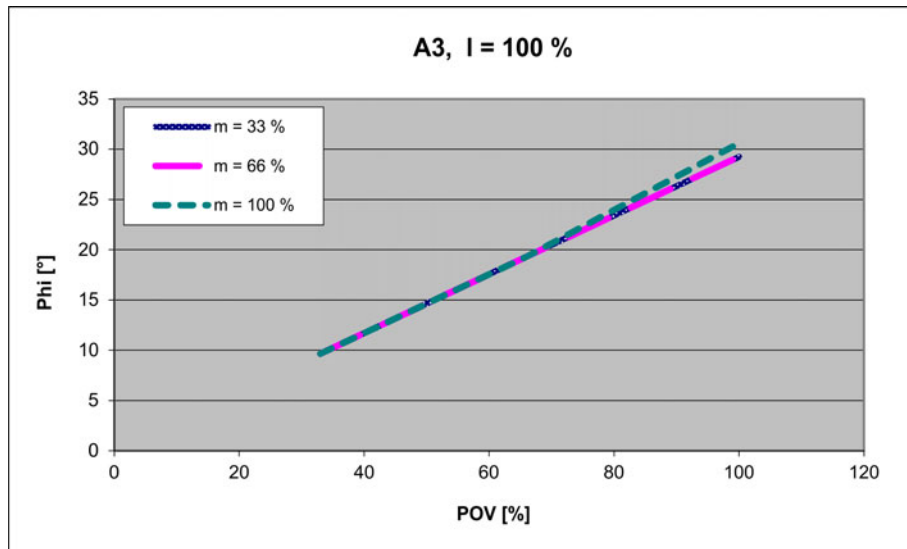

Fig. 4-64: Stopping distances for STOP 1, axis 3

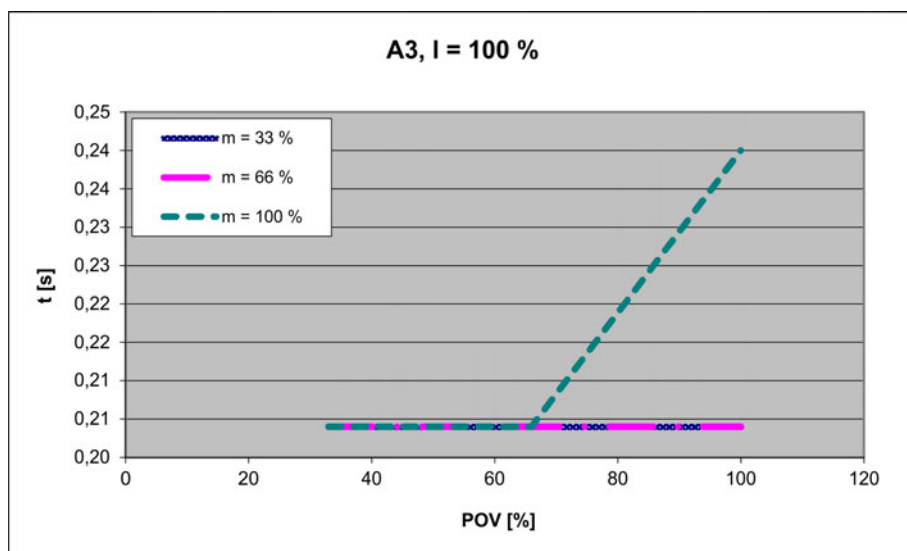

Fig. 4-65: Stopping times for STOP 1, axis 3

#### 4.10.8 Stopping distances and times, KR 10 R900 sixx W and KR 10 R1100 sixx W

The following values are preliminary values and are valid for the following robots.

- KR 10 R900 sixx W
- KR 10 R1100 sixx W

##### 4.10.8.1 Stopping distances and stopping times for STOP 0, axis 1 to axis 3

The table shows the stopping distances and stopping times after a STOP 0 (category 0 stop) is triggered. The values refer to the following configuration:

- Extension I = 100%
- Program override POV = 100%
- Mass m = maximum load (rated load + supplementary load on arm)

	Stopping distance (°)	Stopping time (s)
Axis 1	163.11	0.745
Axis 2	67.78	0.404
Axis 3	60.96	0.387

## 4.10.8.2 Stopping distances and stopping times for STOP 1, axis 1

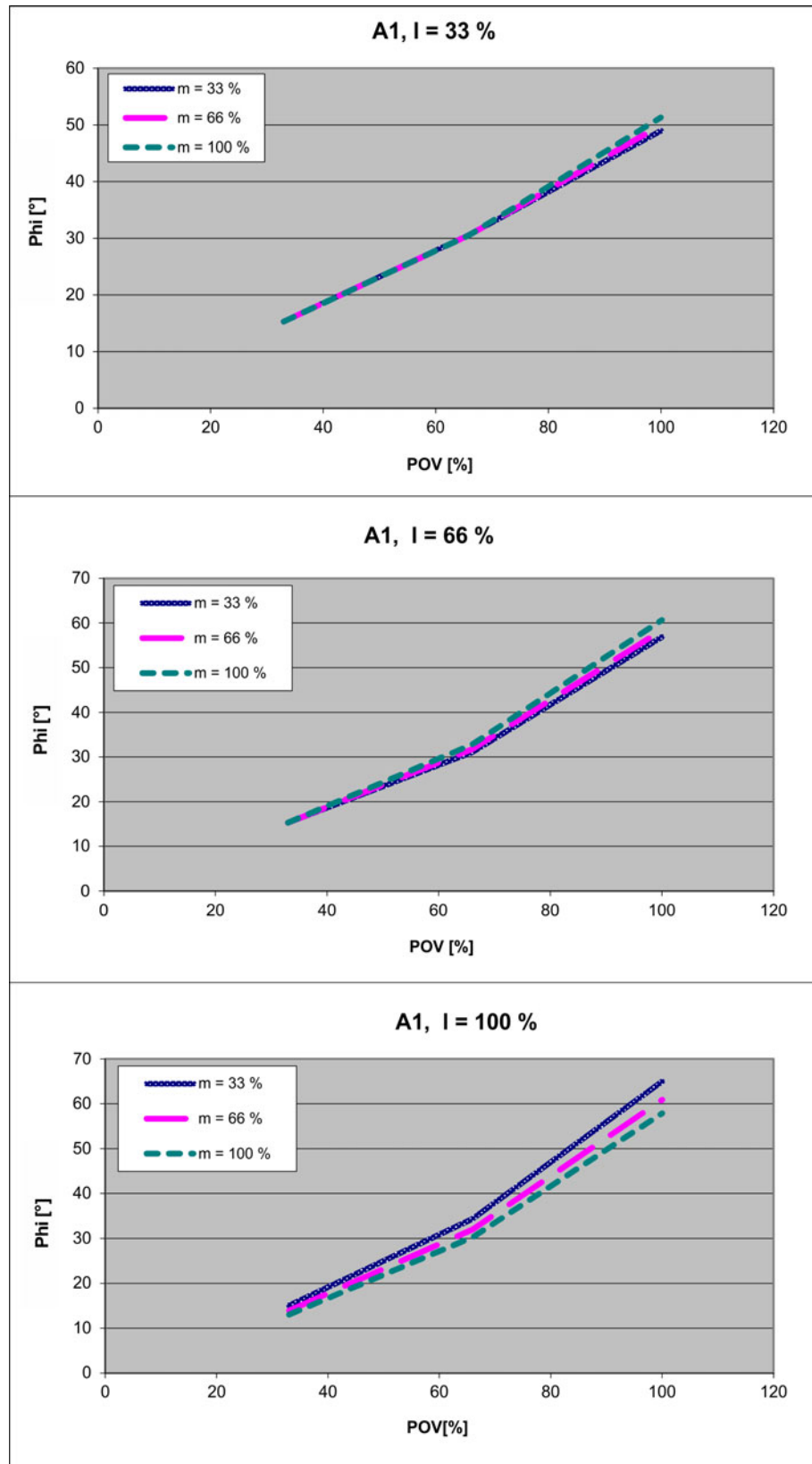

Fig. 4-66: Stopping distances for STOP 1, axis 1

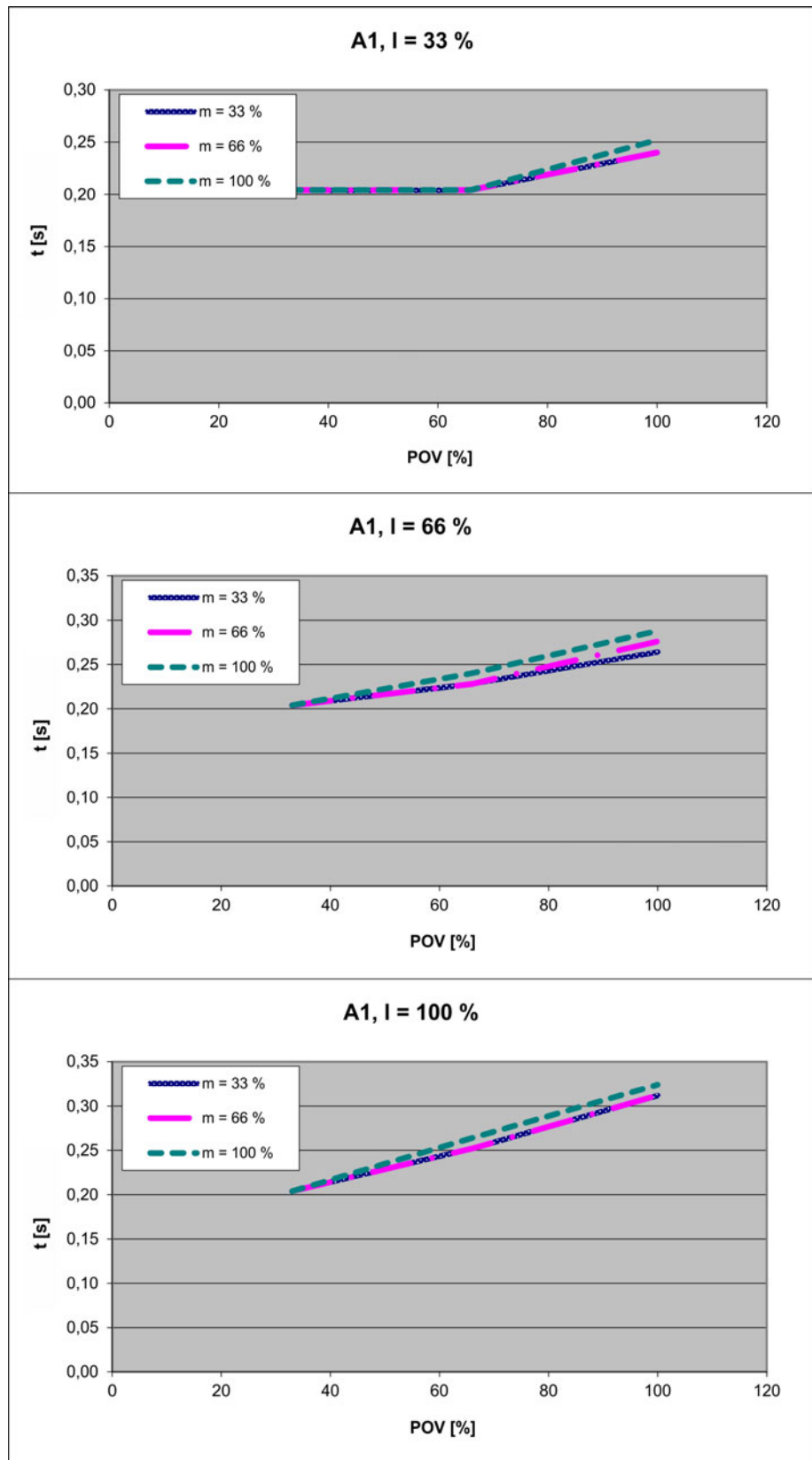

Fig. 4-67: Stopping times for STOP 1, axis 1

## 4.10.8.3 Stopping distances and stopping times for STOP 1, axis 2

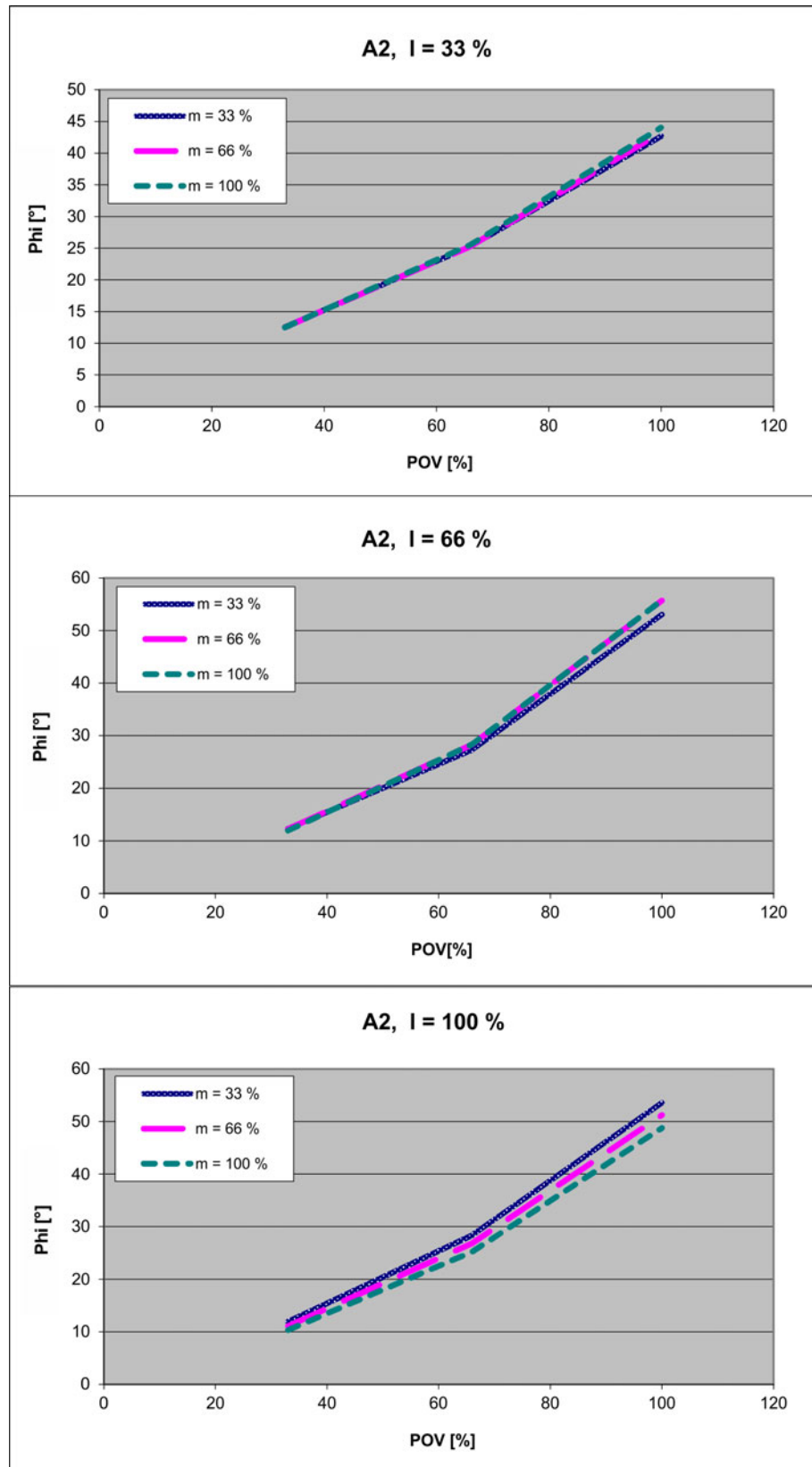

Fig. 4-68: Stopping distances for STOP 1, axis 2

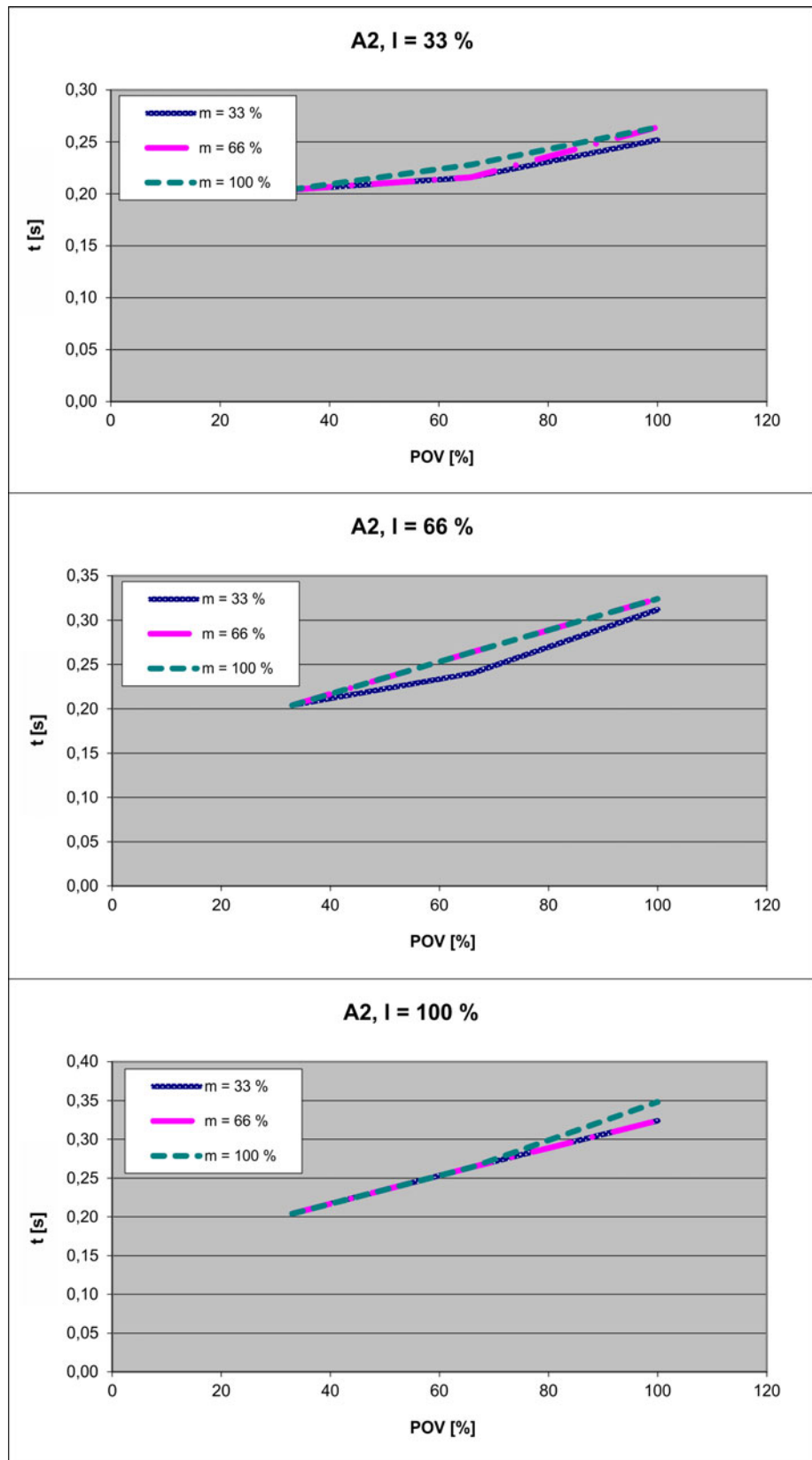

Fig. 4-69: Stopping times for STOP 1, axis 2



## 4.10.8.4 Stopping distances and stopping times for STOP 1, axis 3

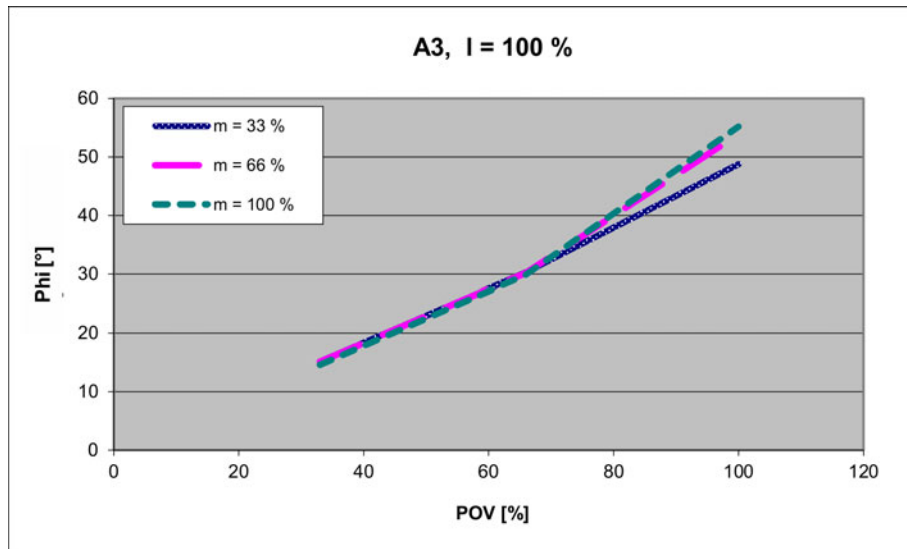

Fig. 4-70: Stopping distances for STOP 1, axis 3

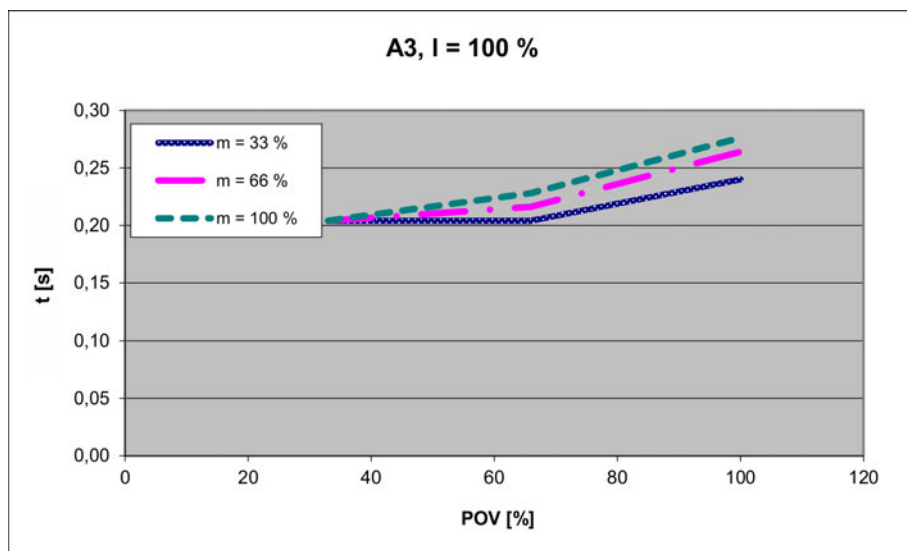

Fig. 4-71: Stopping times for STOP 1, axis 3



## 5 Safety

### 5.1 General



■ This “Safety” chapter refers to a mechanical component of an industrial robot.

■ If the mechanical component is used together with a KUKA robot controller, the “Safety” chapter of the operating instructions or assembly instructions of the robot controller must be used!

This contains all the information provided in this “Safety” chapter. It also contains additional safety information relating to the robot controller which must be observed.

■ Where this “Safety” chapter uses the term “industrial robot”, this also refers to the individual mechanical component if applicable.

#### 5.1.1 Liability

The device described in this document is either an industrial robot or a component thereof.

Components of the industrial robot:

- Manipulator
- Robot controller
- Teach pendant
- Connecting cables
- External axes (optional)  
e.g. linear unit, turn-tilt table, positioner
- Software
- Options, accessories

The industrial robot is built using state-of-the-art technology and in accordance with the recognized safety rules. Nevertheless, misuse of the industrial robot may constitute a risk to life and limb or cause damage to the industrial robot and to other material property.

The industrial robot may only be used in perfect technical condition in accordance with its designated use and only by safety-conscious persons who are fully aware of the risks involved in its operation. Use of the industrial robot is subject to compliance with this document and with the declaration of incorporation supplied together with the industrial robot. Any functional disorders affecting safety must be rectified immediately.

#### Safety information

Safety information cannot be held against KUKA Roboter GmbH. Even if all safety instructions are followed, this is not a guarantee that the industrial robot will not cause personal injuries or material damage.

No modifications may be carried out to the industrial robot without the authorization of KUKA Roboter GmbH. Additional components (tools, software, etc.), not supplied by KUKA Roboter GmbH, may be integrated into the industrial robot. The user is liable for any damage these components may cause to the industrial robot or to other material property.

In addition to the Safety chapter, this document contains further safety instructions. These must also be observed.

### 5.1.2 Intended use of the industrial robot

The industrial robot is intended exclusively for the use designated in the “Purpose” chapter of the operating instructions or assembly instructions.

Any use or application deviating from the intended use is deemed to be misuse and is not allowed. The manufacturer is not liable for any damage resulting from such misuse. The risk lies entirely with the user.

Operation of the industrial robot in accordance with its intended use also requires compliance with the operating and assembly instructions for the individual components, with particular reference to the maintenance specifications.

#### Misuse

Any use or application deviating from the intended use is deemed to be misuse and is not allowed. This includes e.g.:

- Transportation of persons and animals
- Use as a climbing aid
- Operation outside the specified operating parameters
- Use in potentially explosive environments
- Operation without additional safeguards
- Outdoor operation
- Underground operation

### 5.1.3 EC declaration of conformity and declaration of incorporation

The industrial robot constitutes partly completed machinery as defined by the EC Machinery Directive. The industrial robot may only be put into operation if the following preconditions are met:

- The industrial robot is integrated into a complete system.  
Or: The industrial robot, together with other machinery, constitutes a complete system.  
Or: All safety functions and safeguards required for operation in the complete machine as defined by the EC Machinery Directive have been added to the industrial robot.
- The complete system complies with the EC Machinery Directive. This has been confirmed by means of an assessment of conformity.

#### Declaration of conformity

The system integrator must issue a declaration of conformity for the complete system in accordance with the Machinery Directive. The declaration of conformity forms the basis for the CE mark for the system. The industrial robot must always be operated in accordance with the applicable national laws, regulations and standards.

The robot controller is CE certified under the EMC Directive and the Low Voltage Directive.

#### Declaration of incorporation

The industrial robot as partly completed machinery is supplied with a declaration of incorporation in accordance with Annex II B of the EC Machinery Directive 2006/42/EC. The assembly instructions and a list of essential requirements complied with in accordance with Annex I are integral parts of this declaration of incorporation.

The declaration of incorporation declares that the start-up of the partly completed machinery is not allowed until the partly completed machinery has been incorporated into machinery, or has been assembled with other parts to form machinery, and this machinery complies with the terms of the EC Machinery Directive, and the EC declaration of conformity is present in accordance with Annex II A.

### 5.1.4 Terms used

Term	Description
Axis range	Range of each axis, in degrees or millimeters, within which it may move. The axis range must be defined for each axis.
Stopping distance	Stopping distance = reaction distance + braking distance The stopping distance is part of the danger zone.
Workspace	The manipulator is allowed to move within its workspace. The workspace is derived from the individual axis ranges.
Operator (User)	The user of the industrial robot can be the management, employer or delegated person responsible for use of the industrial robot.
Danger zone	The danger zone consists of the workspace and the stopping distances.
Service life	The service life of a safety-relevant component begins at the time of delivery of the component to the customer.  The service life is not affected by whether the component is used in a robot controller or elsewhere or not, as safety-relevant components are also subject to aging during storage.
KCP	KUKA Control Panel  Teach pendant for the KR C2/KR C2 edition2005  The KCP has all the operator control and display functions required for operating and programming the industrial robot.
KUKA smartPAD	see "smartPAD"
Manipulator	The robot arm and the associated electrical installations
Safety zone	The safety zone is situated outside the danger zone.
smartPAD	Teach pendant for the KR C4  The smartPAD has all the operator control and display functions required for operating and programming the industrial robot.
Stop category 0	The drives are deactivated immediately and the brakes are applied. The manipulator and any external axes (optional) perform path-oriented braking.  <b>Note:</b> This stop category is called STOP 0 in this document.
Stop category 1	The manipulator and any external axes (optional) perform path-maintaining braking. The drives are deactivated after 1 s and the brakes are applied.  <b>Note:</b> This stop category is called STOP 1 in this document.
Stop category 2	The drives are not deactivated and the brakes are not applied. The manipulator and any external axes (optional) are braked with a normal braking ramp.  <b>Note:</b> This stop category is called STOP 2 in this document.
System integrator (plant integrator)	System integrators are people who safely integrate the industrial robot into a complete system and commission it.
T1	Test mode, Manual Reduced Velocity ( $\leq 250$ mm/s)
T2	Test mode, Manual High Velocity ( $> 250$ mm/s permissible)
External axis	Motion axis which is not part of the manipulator but which is controlled using the robot controller, e.g. KUKA linear unit, turn-tilt table, Posiflex.

## 5.2 Personnel

The following persons or groups of persons are defined for the industrial robot:

- User

- Personnel



All persons working with the industrial robot must have read and understood the industrial robot documentation, including the safety chapter.

**User**

The user must observe the labor laws and regulations. This includes e.g.:

- The user must comply with his monitoring obligations.
- The user must carry out instructions at defined intervals.

**Personnel**

Personnel must be instructed, before any work is commenced, in the type of work involved and what exactly it entails as well as any hazards which may exist. Instruction must be carried out regularly. Instruction is also required after particular incidents or technical modifications.

Personnel includes:

- System integrator
- Operators, subdivided into:
  - Start-up, maintenance and service personnel
  - Operator
  - Cleaning personnel



Installation, exchange, adjustment, operation, maintenance and repair must be performed only as specified in the operating or assembly instructions for the relevant component of the industrial robot and only by personnel specially trained for this purpose.

**System integrator**

The industrial robot is safely integrated into a complete system by the system integrator.

The system integrator is responsible for the following tasks:

- Installing the industrial robot
- Connecting the industrial robot
- Performing risk assessment
- Implementing the required safety functions and safeguards
- Issuing the declaration of conformity
- Attaching the CE mark
- Creating the operating instructions for the complete system

**Operator**

The operator must meet the following preconditions:

- The operator must be trained for the work to be carried out.
- Work on the industrial robot must only be carried out by qualified personnel. These are people who, due to their specialist training, knowledge and experience, and their familiarization with the relevant standards, are able to assess the work to be carried out and detect any potential hazards.



Work on the electrical and mechanical equipment of the industrial robot may only be carried out by specially trained personnel.

### 5.3 Workspace, safety zone and danger zone

Workspaces are to be restricted to the necessary minimum size. A workspace must be safeguarded using appropriate safeguards.

The safeguards (e.g. safety gate) must be situated inside the safety zone. In the case of a stop, the manipulator and external axes (optional) are braked and come to a stop within the danger zone.

The danger zone consists of the workspace and the stopping distances of the manipulator and external axes (optional). It must be safeguarded by means of physical safeguards to prevent danger to persons or the risk of material damage.

## 5.4 Overview of protective equipment

The protective equipment of the mechanical component may include:

- Mechanical end stops
- Mechanical axis range limitation (optional)
- Axis range monitoring (optional)
- Release device (optional)
- Labeling of danger areas

Not all equipment is relevant for every mechanical component.

### 5.4.1 Mechanical end stops

Depending on the robot variant, the axis ranges of the main and wrist axes of the manipulator are partially limited by mechanical end stops.

Additional mechanical end stops can be installed on the external axes.

 **WARNING** If the manipulator or an external axis hits an obstruction or a mechanical end stop or axis range limitation, the manipulator can no longer be operated safely. The manipulator must be taken out of operation and KUKA Roboter GmbH must be consulted before it is put back into operation (>>> 13 "KUKA Service" Page 183).

### 5.4.2 Mechanical axis range limitation (optional)

Some manipulators can be fitted with mechanical axis range limitation in axes A1 to A3. The adjustable axis range limitation systems restrict the working range to the required minimum. This increases personal safety and protection of the system.

In the case of manipulators that are not designed to be fitted with mechanical axis range limitation, the workspace must be laid out in such a way that there is no danger to persons or material property, even in the absence of mechanical axis range limitation.

If this is not possible, the workspace must be limited by means of photoelectric barriers, photoelectric curtains or obstacles on the system side. There must be no shearing or crushing hazards at the loading and transfer areas.

 This option is not available for all robot models. Information on specific robot models can be obtained from KUKA Roboter GmbH.

### 5.4.3 Axis range monitoring (optional)

Some manipulators can be fitted with dual-channel axis range monitoring systems in main axes A1 to A3. The positioner axes may be fitted with additional axis range monitoring systems. The safety zone for an axis can be adjusted

and monitored using an axis range monitoring system. This increases personal safety and protection of the system.



This option is not available for the KR C4. This option is not available for all robot models. Information on specific robot models can be obtained from KUKA Roboter GmbH.

#### 5.4.4 Options for moving the manipulator without drive energy



The system user is responsible for ensuring that the training of personnel with regard to the response to emergencies or exceptional situations also includes how the manipulator can be moved without drive energy.

##### Description

The following options are available for moving the manipulator without drive energy after an accident or malfunction:

- Release device (optional)  
The release device can be used for the main axis drive motors and, depending on the robot variant, also for the wrist axis drive motors.
- Brake release device (option)  
The brake release device is designed for robot variants whose motors are not freely accessible.
- Moving the wrist axes directly by hand  
There is no release device available for the wrist axes of variants in the low payload category. This is not necessary because the wrist axes can be moved directly by hand.



Information about the options available for the various robot models and about how to use them can be found in the assembly and operating instructions for the robot or requested from KUKA Roboter GmbH.

##### **NOTICE**

Moving the manipulator without drive energy can damage the motor brakes of the axes concerned. The motor must be replaced if the brake has been damaged. The manipulator may therefore be moved without drive energy only in emergencies, e.g. for rescuing persons.

#### 5.4.5 Labeling on the industrial robot

All plates, labels, symbols and marks constitute safety-relevant parts of the industrial robot. They must not be modified or removed.

Labeling on the industrial robot consists of:

- Identification plates
- Warning signs
- Safety symbols
- Designation labels
- Cable markings
- Rating plates



Further information is contained in the technical data of the operating instructions or assembly instructions of the components of the industrial robot.



## 5.5 Safety measures

### 5.5.1 General safety measures

The industrial robot may only be used in perfect technical condition in accordance with its intended use and only by safety-conscious persons. Operator errors can result in personal injury and damage to property.

It is important to be prepared for possible movements of the industrial robot even after the robot controller has been switched off and locked out. Incorrect installation (e.g. overload) or mechanical defects (e.g. brake defect) can cause the manipulator or external axes to sag. If work is to be carried out on a switched-off industrial robot, the manipulator and external axes must first be moved into a position in which they are unable to move on their own, whether the payload is mounted or not. If this is not possible, the manipulator and external axes must be secured by appropriate means.

**⚠ DANGER** In the absence of operational safety functions and safeguards, the industrial robot can cause personal injury or material damage. If safety functions or safeguards are dismantled or deactivated, the industrial robot may not be operated.

**⚠ DANGER** Standing underneath the robot arm can cause death or injuries. For this reason, standing underneath the robot arm is prohibited!

**⚠ CAUTION** The motors reach temperatures during operation which can cause burns to the skin. Contact must be avoided. Appropriate safety precautions must be taken, e.g. protective gloves must be worn.

#### KCP/smartPAD

The user must ensure that the industrial robot is only operated with the KCP/smartPAD by authorized persons.

If more than one KCP/smartPAD is used in the overall system, it must be ensured that each device is unambiguously assigned to the corresponding industrial robot. They must not be interchanged.

**⚠ WARNING** The operator must ensure that decoupled KCPs/smartPADs are immediately removed from the system and stored out of sight and reach of personnel working on the industrial robot. This serves to prevent operational and non-operational EMERGENCY STOP devices from becoming interchanged. Failure to observe this precaution may result in death, severe injuries or considerable damage to property.

#### External keyboard, external mouse

An external keyboard and/or external mouse may only be used if the following conditions are met:

- Start-up or maintenance work is being carried out.
- The drives are switched off.
- There are no persons in the danger zone.

The KCP/smartPAD must not be used as long as an external keyboard and/or external mouse are connected to the control cabinet.

The external keyboard and/or external mouse must be removed from the control cabinet as soon as the start-up or maintenance work is completed or the KCP/smartPAD is connected.

<b>Modifications</b>	<p>After modifications to the industrial robot, checks must be carried out to ensure the required safety level. The valid national or regional work safety regulations must be observed for this check. The correct functioning of all safety functions must also be tested.</p> <p>New or modified programs must always be tested first in Manual Reduced Velocity mode (T1).</p> <p>After modifications to the industrial robot, existing programs must always be tested first in Manual Reduced Velocity mode (T1). This applies to all components of the industrial robot and includes modifications to the software and configuration settings.</p>
<b>Faults</b>	<p>The following tasks must be carried out in the case of faults in the industrial robot:</p> <ul style="list-style-type: none"> <li>■ Switch off the robot controller and secure it (e.g. with a padlock) to prevent unauthorized persons from switching it on again.</li> <li>■ Indicate the fault by means of a label with a corresponding warning (tag-out).</li> <li>■ Keep a record of the faults.</li> <li>■ Eliminate the fault and carry out a function test.</li> </ul>

### 5.5.2 Transportation

<b>Manipulator</b>	<p>The prescribed transport position of the manipulator must be observed. Transportation must be carried out in accordance with the operating instructions or assembly instructions of the robot.</p> <p>Avoid vibrations and impacts during transportation in order to prevent damage to the manipulator.</p>
<b>Robot controller</b>	<p>The prescribed transport position of the robot controller must be observed. Transportation must be carried out in accordance with the operating instructions or assembly instructions of the robot controller.</p> <p>Avoid vibrations and impacts during transportation in order to prevent damage to the robot controller.</p>
<b>External axis (optional)</b>	<p>The prescribed transport position of the external axis (e.g. KUKA linear unit, turn-tilt table, positioner) must be observed. Transportation must be carried out in accordance with the operating instructions or assembly instructions of the external axis.</p>

### 5.5.3 Start-up and recommissioning

Before starting up systems and devices for the first time, a check must be carried out to ensure that the systems and devices are complete and operational, that they can be operated safely and that any damage is detected.

The valid national or regional work safety regulations must be observed for this check. The correct functioning of all safety circuits must also be tested.



The passwords for logging onto the KUKA System Software as “Expert” and “Administrator” must be changed before start-up and must only be communicated to authorized personnel.

**⚠ WARNING** The robot controller is preconfigured for the specific industrial robot. If cables are interchanged, the manipulator and the external axes (optional) may receive incorrect data and can thus cause personal injury or material damage. If a system consists of more than one manipulator, always connect the connecting cables to the manipulators and their corresponding robot controllers.

**⚠** If additional components (e.g. cables), which are not part of the scope of supply of KUKA Roboter GmbH, are integrated into the industrial robot, the user is responsible for ensuring that these components do not adversely affect or disable safety functions.

**NOTICE** If the internal cabinet temperature of the robot controller differs greatly from the ambient temperature, condensation can form, which may cause damage to the electrical components. Do not put the robot controller into operation until the internal temperature of the cabinet has adjusted to the ambient temperature.

### Function test

The following tests must be carried out before start-up and recommissioning:  
It must be ensured that:

- The industrial robot is correctly installed and fastened in accordance with the specifications in the documentation.
- There are no foreign bodies or loose parts on the industrial robot.
- All required safety equipment is correctly installed and operational.
- The power supply ratings of the industrial robot correspond to the local supply voltage and mains type.
- The ground conductor and the equipotential bonding cable are sufficiently rated and correctly connected.
- The connecting cables are correctly connected and the connectors are locked.

### Machine data

It must be ensured that the rating plate on the robot controller has the same machine data as those entered in the declaration of incorporation. The machine data on the rating plate of the manipulator and the external axes (optional) must be entered during start-up.

**⚠ WARNING** The industrial robot must not be moved if incorrect machine data are loaded. Death, severe injuries or considerable damage to property may otherwise result. The correct machine data must be loaded.

## 5.5.4 Manual mode

Manual mode is the mode for setup work. Setup work is all the tasks that have to be carried out on the industrial robot to enable automatic operation. Setup work includes:

- Jog mode
- Teaching
- Programming
- Program verification

The following must be taken into consideration in manual mode:

- If the drives are not required, they must be switched off to prevent the manipulator or the external axes (optional) from being moved unintentionally.

- New or modified programs must always be tested first in Manual Reduced Velocity mode (T1).
- The manipulator, tooling or external axes (optional) must never touch or project beyond the safety fence.
- Workpieces, tooling and other objects must not become jammed as a result of the industrial robot motion, nor must they lead to short-circuits or be liable to fall off.
- All setup work must be carried out, where possible, from outside the safeguarded area.

If the setup work has to be carried out inside the safeguarded area, the following must be taken into consideration:

**In Manual Reduced Velocity mode (T1):**

- If it can be avoided, there must be no other persons inside the safeguarded area.  
If it is necessary for there to be several persons inside the safeguarded area, the following must be observed:
  - Each person must have an enabling device.
  - All persons must have an unimpeded view of the industrial robot.
  - Eye-contact between all persons must be possible at all times.
- The operator must be so positioned that he can see into the danger area and get out of harm's way.

**In Manual High Velocity mode (T2):**

- This mode may only be used if the application requires a test at a velocity higher than Manual Reduced Velocity.
- Teaching and programming are not permissible in this operating mode.
- Before commencing the test, the operator must ensure that the enabling devices are operational.
- The operator must be positioned outside the danger zone.
- There must be no other persons inside the safeguarded area. It is the responsibility of the operator to ensure this.

### 5.5.5 Automatic mode

Automatic mode is only permissible in compliance with the following safety measures:

- All safety equipment and safeguards are present and operational.
- There are no persons in the system.
- The defined working procedures are adhered to.

If the manipulator or an external axis (optional) comes to a standstill for no apparent reason, the danger zone must not be entered until an EMERGENCY STOP has been triggered.

### 5.5.6 Maintenance and repair

After maintenance and repair work, checks must be carried out to ensure the required safety level. The valid national or regional work safety regulations must be observed for this check. The correct functioning of all safety functions must also be tested.

The purpose of maintenance and repair work is to ensure that the system is kept operational or, in the event of a fault, to return the system to an operational state. Repair work includes troubleshooting in addition to the actual repair itself.

The following safety measures must be carried out when working on the industrial robot:

- Carry out work outside the danger zone. If work inside the danger zone is necessary, the user must define additional safety measures to ensure the safe protection of personnel.
- Switch off the industrial robot and secure it (e.g. with a padlock) to prevent it from being switched on again. If it is necessary to carry out work with the robot controller switched on, the user must define additional safety measures to ensure the safe protection of personnel.
- If it is necessary to carry out work with the robot controller switched on, this may only be done in operating mode T1.
- Label the system with a sign indicating that work is in progress. This sign must remain in place, even during temporary interruptions to the work.
- The EMERGENCY STOP devices must remain active. If safety functions or safeguards are deactivated during maintenance or repair work, they must be reactivated immediately after the work is completed.

 <b style="color: white; background-color: red; padding: 2px;">DANGER</b>	<p>Before work is commenced on live parts of the robot system, the main switch must be turned off and secured against being switched on again. The system must then be checked to ensure that it is deenergized.</p> <p>It is not sufficient, before commencing work on live parts, to execute an EMERGENCY STOP or a safety stop, or to switch off the drives, as this does not disconnect the robot system from the mains power supply. Parts remain energized. Death or severe injuries may result.</p>
--	--

Faulty components must be replaced using new components with the same article numbers or equivalent components approved by KUKA Roboter GmbH for this purpose.

Cleaning and preventive maintenance work is to be carried out in accordance with the operating instructions.

### Robot controller

Even when the robot controller is switched off, parts connected to peripheral devices may still carry voltage. The external power sources must therefore be switched off if work is to be carried out on the robot controller.

The ESD regulations must be adhered to when working on components in the robot controller.

Voltages in excess of 50 V (up to 600 V) can be present in various components for several minutes after the robot controller has been switched off! To prevent life-threatening injuries, no work may be carried out on the industrial robot in this time.

Water and dust must be prevented from entering the robot controller.

### Counterbalancing system

Some robot variants are equipped with a hydropneumatic, spring or gas cylinder counterbalancing system.

The hydropneumatic and gas cylinder counterbalancing systems are pressure equipment and, as such, are subject to obligatory equipment monitoring and the provisions of the Pressure Equipment Directive.

The user must comply with the applicable national laws, regulations and standards pertaining to pressure equipment.

Inspection intervals in Germany in accordance with Industrial Safety Order, Sections 14 and 15. Inspection by the user before commissioning at the installation site.

The following safety measures must be carried out when working on the counterbalancing system:

- The manipulator assemblies supported by the counterbalancing systems must be secured.
- Work on the counterbalancing systems must only be carried out by qualified personnel.

#### Hazardous substances

The following safety measures must be carried out when handling hazardous substances:

- Avoid prolonged and repeated intensive contact with the skin.
- Avoid breathing in oil spray or vapors.
- Clean skin and apply skin cream.



To ensure safe use of our products, we recommend that our customers regularly request up-to-date safety data sheets from the manufacturers of hazardous substances.

#### 5.5.7 Decommissioning, storage and disposal

The industrial robot must be decommissioned, stored and disposed of in accordance with the applicable national laws, regulations and standards.

### 5.6 Applied norms and regulations

Name	Definition	Edition
2006/42/EC	<b>Machinery Directive:</b> Directive 2006/42/EC of the European Parliament and of the Council of 17 May 2006 on machinery, and amending Directive 95/16/EC (recast)	2006
2004/108/EC	<b>EMC Directive:</b> Directive 2004/108/EC of the European Parliament and of the Council of 15 December 2004 on the approximation of the laws of the Member States relating to electromagnetic compatibility and repealing Directive 89/336/EEC	2004
97/23/EC	<b>Pressure Equipment Directive:</b> Directive 97/23/EC of the European Parliament and of the Council of 29 May 1997 on the approximation of the laws of the Member States concerning pressure equipment  (Only applicable for robots with hydropneumatic counterbalancing system.)	1997
EN ISO 13850	<b>Safety of machinery:</b> Emergency stop - Principles for design	2008
EN ISO 13849-1	<b>Safety of machinery:</b> Safety-related parts of control systems - Part 1: General principles of design	2008
EN ISO 13849-2	<b>Safety of machinery:</b> Safety-related parts of control systems - Part 2: Validation	2012

<b>EN ISO 12100</b>	<b>Safety of machinery:</b> General principles of design, risk assessment and risk reduction	2010
<b>EN ISO 10218-1</b>	<b>Industrial robots:</b> Safety <b>Note:</b> Content equivalent to <b>ANSI/RIA R.15.06-2012, Part 1</b>	2011
<b>EN 614-1 + A1</b>	<b>Safety of machinery:</b> Ergonomic design principles - Part 1: Terms and general principles	2009
<b>EN 61000-6-2</b>	<b>Electromagnetic compatibility (EMC):</b> Part 6-2: Generic standards; Immunity for industrial environments	2005
<b>EN 61000-6-4 + A1</b>	<b>Electromagnetic compatibility (EMC):</b> Part 6-4: Generic standards; Emission standard for industrial environments	2011
<b>EN 60204-1 + A1</b>	<b>Safety of machinery:</b> Electrical equipment of machines - Part 1: General requirements	2009





## 6 Planning

### 6.1 Information for planning

In the planning and design phase, care must be taken regarding the functions or applications to be executed by the kinematic system. The following conditions can lead to premature wear. They necessitate shorter maintenance intervals and/or earlier exchange of components. In addition, the permissible operating parameters specified in the technical data must be taken into account during planning.

- Continuous operation near temperature limits or in abrasive environments
- Continuous operation close to the performance limits, e.g. high rpm of an axis
- High duty cycle of individual axes
- Monotonous motion profiles, e.g. short, frequently recurring axis motions
- Static axis positions, e.g. continuous vertical position of a wrist axis

If one or more of these conditions are to apply during operation of the kinematic system, KUKA Roboter GmbH must be consulted.

### 6.2 Mounting base

**Description** The mounting base with centering is used when the robot is fastened to the floor, i.e. directly on a concrete foundation.

The mounting base consists of:

- Bedplate
- Chemical anchors (resin-bonded anchors) with Dynamic Set
- Fasteners

This mounting variant requires a level and smooth surface on a concrete foundation with adequate load bearing capacity. The concrete foundation must be able to accommodate the forces occurring during operation. The minimum dimensions must be observed.

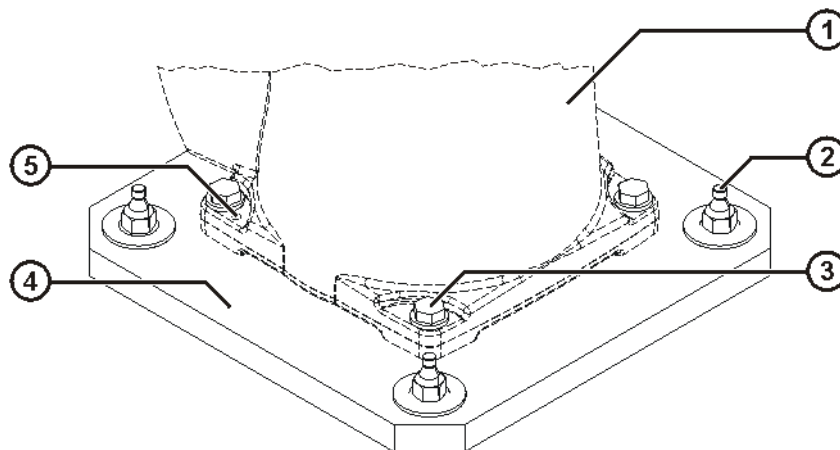

**Fig. 6-1: Mounting base**

- |   |               |
|---|---------------|
| 1 Robot base frame                      | 4 Bedplate    |
| 2 Chemical anchor (resin-bonded anchor) | 5 Stepped pin |
| 3 Hexagon bolt                          |               |

### Grade of concrete for foundations

When producing foundations from concrete, observe the load-bearing capacity of the ground and the country-specific construction regulations. There must be no layers of insulation or screed between the bedplates and the concrete foundation. The quality of the concrete must meet the requirements of the following standard:

- C20/25 according to DIN EN 206-1:2001/DIN 1045-2:2008

### Dimensioned drawing

The following illustration (>>> Fig. 6-2 ) provides all the necessary information on the mounting base, together with the required foundation data.

Dimensions: mm

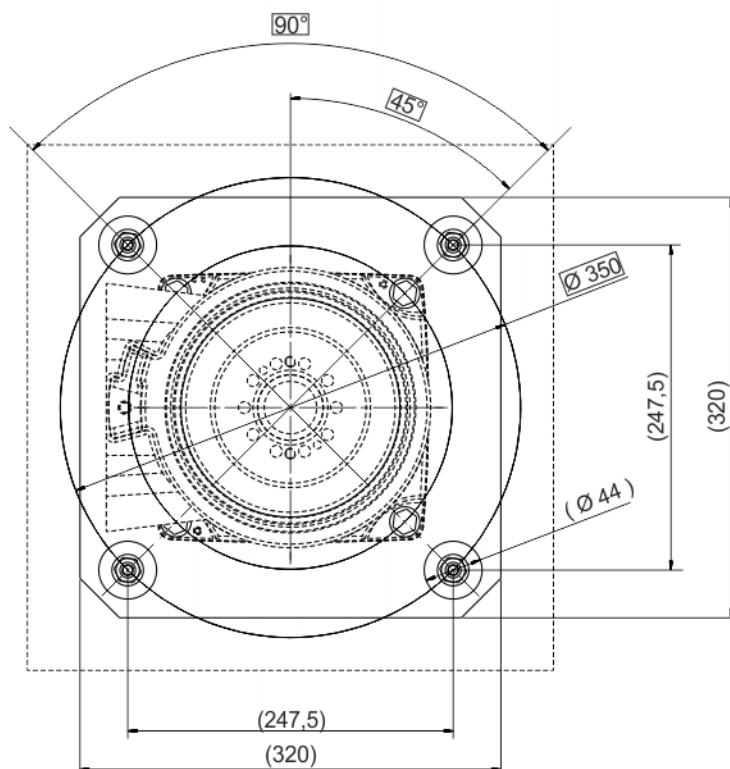

**Fig. 6-2: Dimensioned drawing, mounting base**

To ensure that the anchor forces are safely transmitted to the foundation, observe the dimensions for concrete foundations specified in the following illustration (>>> Fig. 6-3 ).

Dimensions: mm

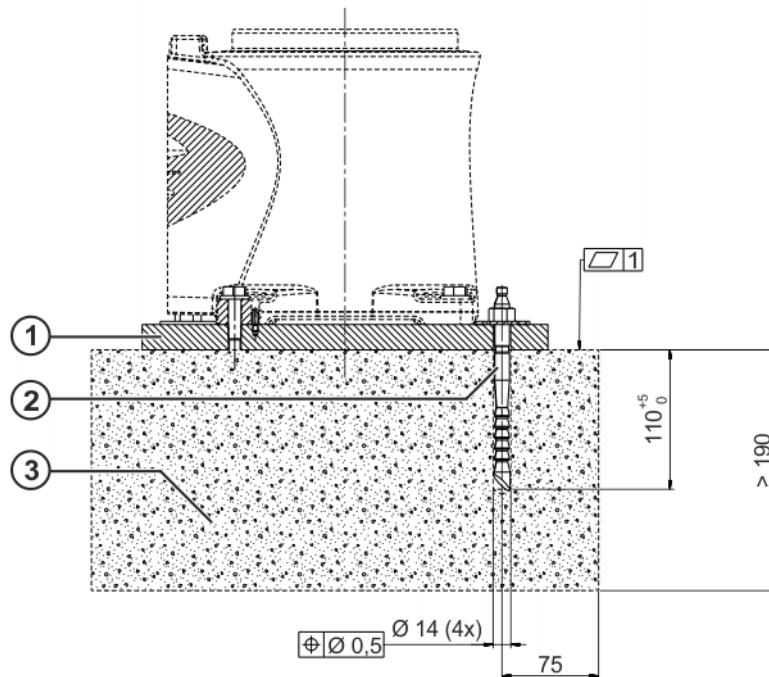

**Fig. 6-3: Cross-section of foundations**

- 1 Bedplate
- 2 Chemical anchor (resin-bonded anchors) with Dynamic Set
- 3 Concrete foundation

### 6.3 Machine frame mounting

#### Description

The machine frame mounting assembly is used when the robot is fastened on a steel structure, a booster frame (pedestal) or a KUKA linear unit. This assembly is also used if the robot is installed on the wall or ceiling. It must be ensured that the substructure is able to withstand safely the forces occurring during operation (foundation loads). The following diagram contains all the necessary information that must be observed when preparing the mounting surface (>>> Fig. 6-4).

The machine frame mounting assembly consists of:

- Stepped pin
- Hexagon bolts with conical spring washers

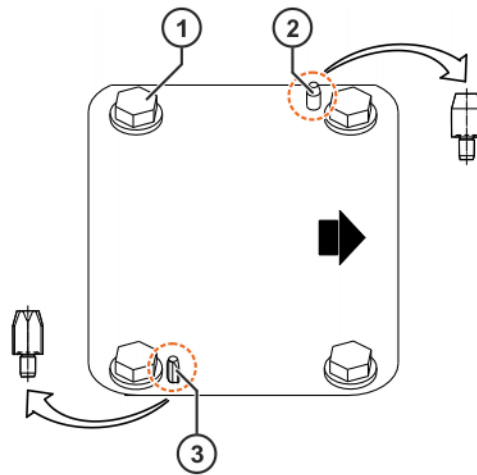

**Fig. 6-4: Machine frame mounting**

- 1 Hexagon bolt
- 2 Cylindrical stepped pin
- 3 Flat-sided stepped pin

**Dimensioned  
drawing**

The following illustration (>>> Fig. 6-5 ) provides all the necessary information on machine frame mounting, together with the required foundation data.

Dimensions: mm

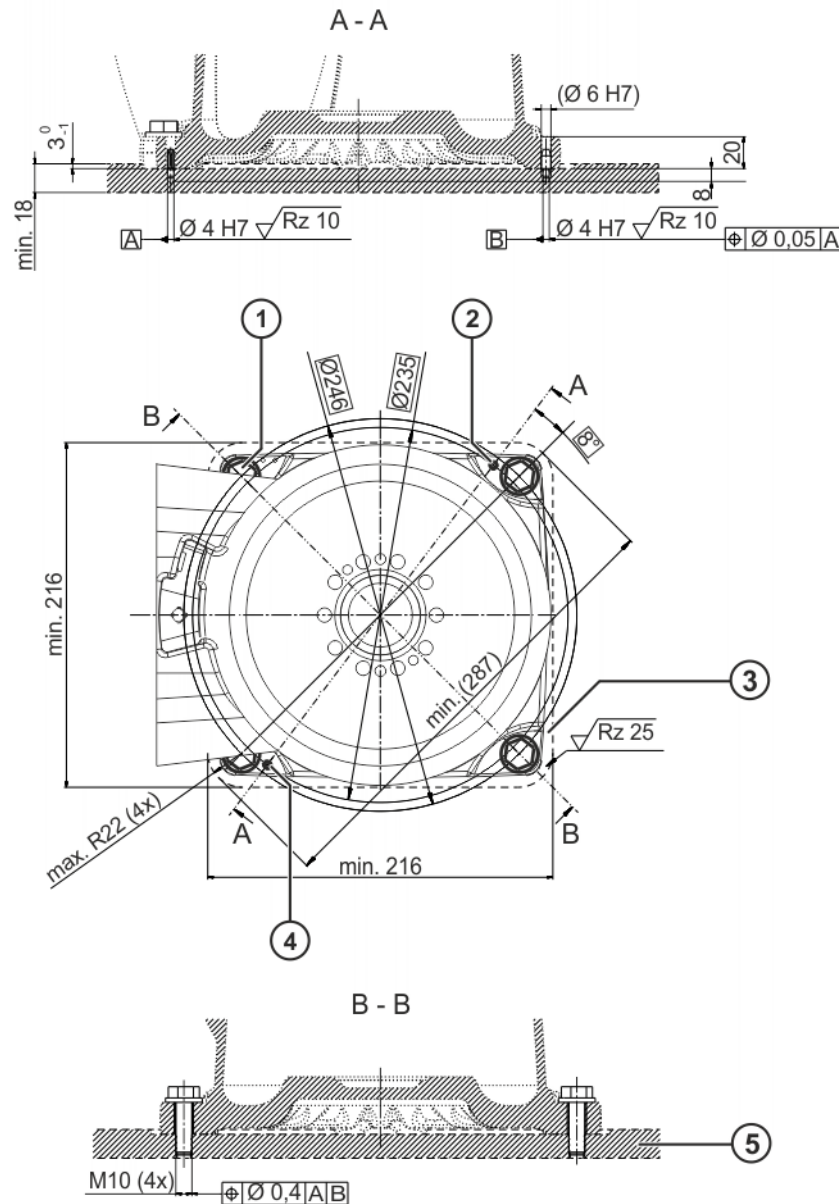

**Fig. 6-5: Machine frame mounting, dimensioned drawing**

- |                           |                          |
|---------------------------|--------------------------|
| 1 Hexagon bolt (4x)       | 4 Flat-sided stepped pin |
| 2 Cylindrical stepped pin | 5 Steel structure        |
| 3 Mounting surface        |                          |

## 6.4 Connecting cables and interfaces

### Connecting cables

The connecting cables comprise all the cables for transferring energy and signals between the robot and the robot controller. They are connected to the robot junction boxes with connectors. The set of connecting cables comprises:

- Motor cable
- Data cable
- CAT5 data cable (optional)
- Connecting cable, external axes A7 and A8 (optional)
- Ground conductor (optional)

Depending on the specification of the robot, various connecting cables are used. The standard cable length is 4 m. Cable lengths of 1 m, 7 m, 15 m and 25 m are available as an option. The maximum length of the connecting cables must not exceed 25 m. Thus if the robot is operated on a linear unit which has its own energy supply chain these cables must also be taken into account.



For the connecting cables, a ground conductor is always required to provide a low-resistance connection between the robot and the control cabinet in accordance with DIN EN 60204. The ground conductor is not part of the scope of supply and can be ordered as an option. The connection must be made by the customer. The tapped holes for connecting the ground conductor are located on the base frame of the robot.

The following points must be observed when planning and routing the connecting cables:

- The bending radius for fixed routing must not be less than 50 mm for motor cables and 30 mm for control cables.
- Protect cables against exposure to mechanical stress.
- Route the cables without mechanical stress – no tensile forces on the connectors
- Cables are only to be installed indoors.
- Observe permissible temperature range (fixed installation) of 263 K (-10 °C) to 343 K (+70 °C).
- Route the motor cables and the control cables separately in metal ducts; if necessary, additional measures must be taken to ensure electromagnetic compatibility (EMC).

### Interface A1

Interface A1 is located at the rear of the base frame. The connections for the motor and data cables are shown in the following illustration.

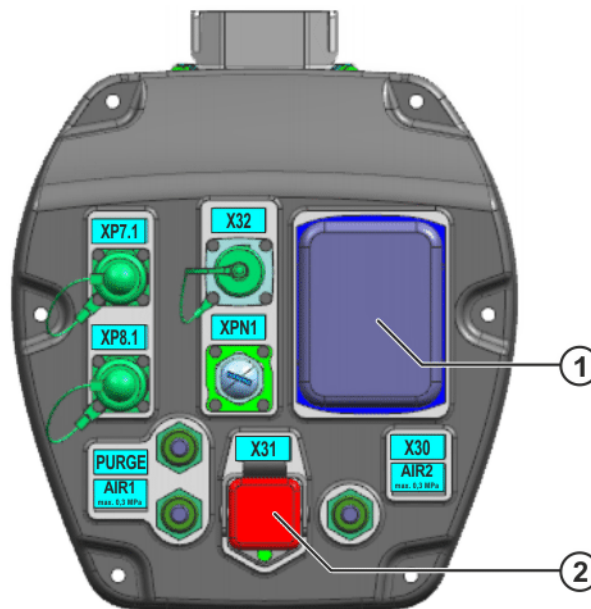

**Fig. 6-6: Interface A1**

- 1 Connection, motor cable X30
- 2 Connection, data cable, X31

## 6.5 Customer interfaces

### Interface A1

Interface A1 is located at the rear of the base frame.

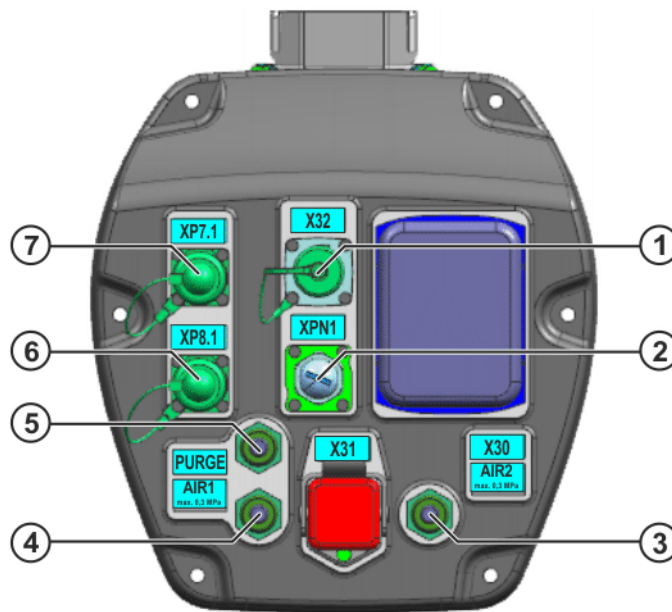
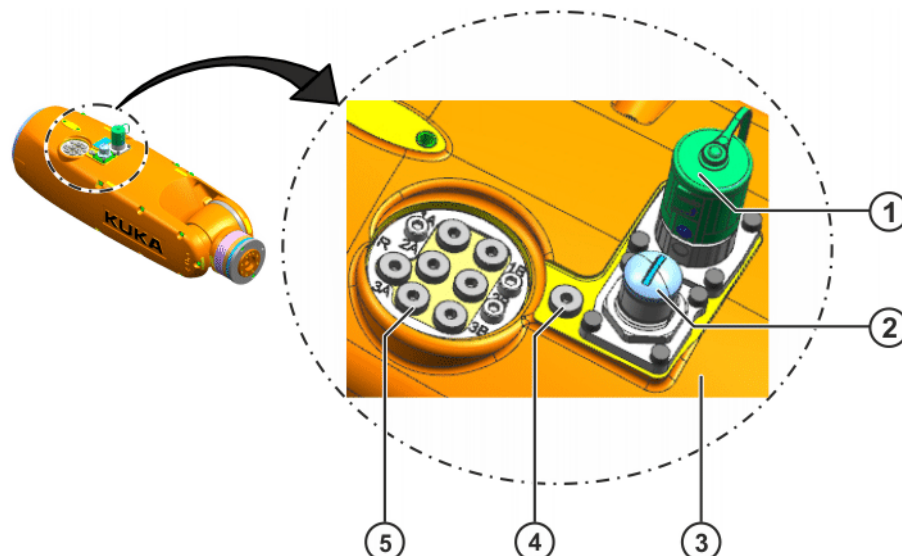

**Fig. 6-7: Customer interface A1**

- 1 MicroEMD connection X32
- 2 CAT5 data cable connection XPN1
- 3 Air line connection AIR2  
Outside diameter: 6 mm
- 4 Air line connection AIR1  
Outside diameter: 6 mm
- 5 Pressurization connection (optional)  
Max. pressure: 0.3 bar  
Air, oil-free, dry, filtered  
according to: ISO 8573.1-1, 1.2 to 16.2
- 6 Connection for external axis A8 (XP8.1)
- 7 Connection for external axis A7 (XP7.1)

#### Interface A4

Interface A4 is located on top of the in-line wrist.



**Fig. 6-8: Interface A4, example**

- 1 Connection X41
- 2 Connection XPN41
- 3 In-line wrist
- 4 Air line AIR2
- 5 Air connections

The optional connector bypack is required for use of the air connections. This option contains a silencer and several plug-in couplings (>>> Fig. 6-9).

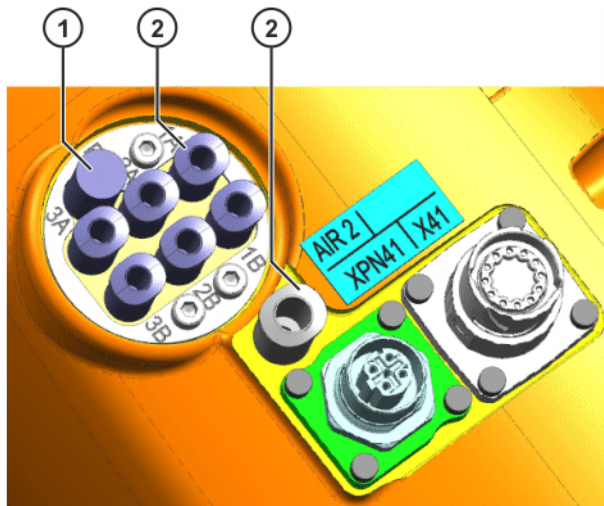

**Fig. 6-9: Connector bypack option**

- 1 Silencer
- 2 Push-in fitting

The robot has three bistable 5/2-way solenoid valves integrated into the in-line wrist. The valve unit is activated via the internal energy supply system:

Designation	Limit values
Valve type	5/2-way solenoid valve
Max. pressure	7 bar
Switching frequency	10 Hz
Operating temperature	+5 °C to +45 °C (278 K to 318 K) condensation-free
Threaded union	M5
Fluid	Air, oil-free, dry, filtered according to: ISO 8573.1-1, 1.2 to 16.2 Degree of filtration: max. 5 µm
Operating voltage	24 V DC
Current	25 mA



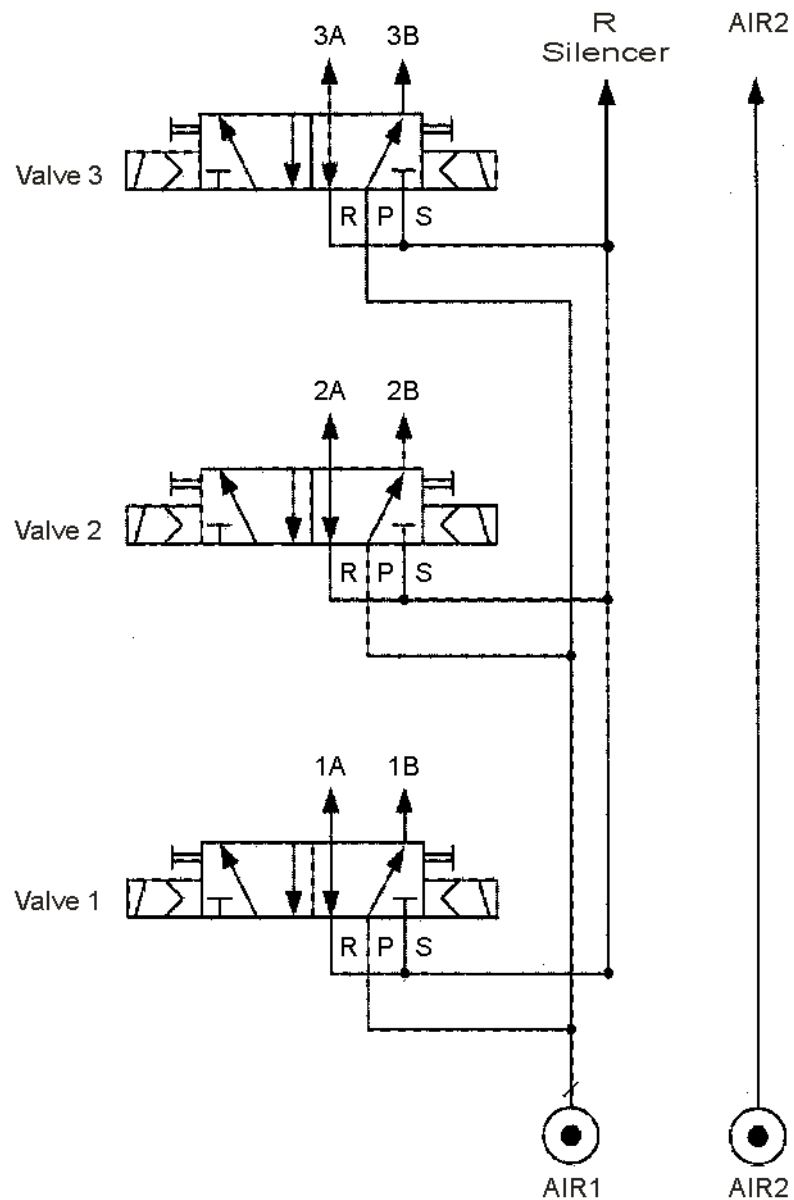

Fig. 6-10: Valve diagram

## Valve activation

Designation	Values
Digital outputs (for valve activation)	6 (DO7 to DO12): <ul style="list-style-type: none"> <li>■ Valve 1: DO7/DO10</li> <li>■ Valve 2: DO8/DO11</li> <li>■ Valve 3: DO9/DO12</li> </ul> not short circuit proof
Rated voltage	24 V DC (-15%/+20%)
Output current	max. 25 mA



The inputs and outputs are not preconfigured and must be configured in WorkVisual.  
 Further information about mapping inputs and outputs can be found in the **WorkVisual** documentation.

Connection X41

Designation		Values
Digital outputs (for customer interface X41)		2 (DO13, DO14) short-circuit proof
	Rated voltage	24 V DC (-15%/+20%)
	Output current	max. 0.5 A
	Short-circuit current	max. 2 A
	Load type	Ohmic, inductive Lamp load
Digital inputs (for customer interface X41)		6 (DI1 to DI6)
	Signal voltage "0"	-3 V ... +5 V EN 61131-2, type 3
	Signal voltage "1"	15 V ... 30 V EN 61131-2, type 3
	Input current	typically 3 mA EN 61131-2, type 3
	Input filter	typically 0.3 ms
Power supply		24 V / 3 A

A 615springtec® connector, 12-pole EMC enclosure E-part from Intercontec is required for connection X41.

For the connector bypack option, the pin assignments on the connector insert are to be noted.

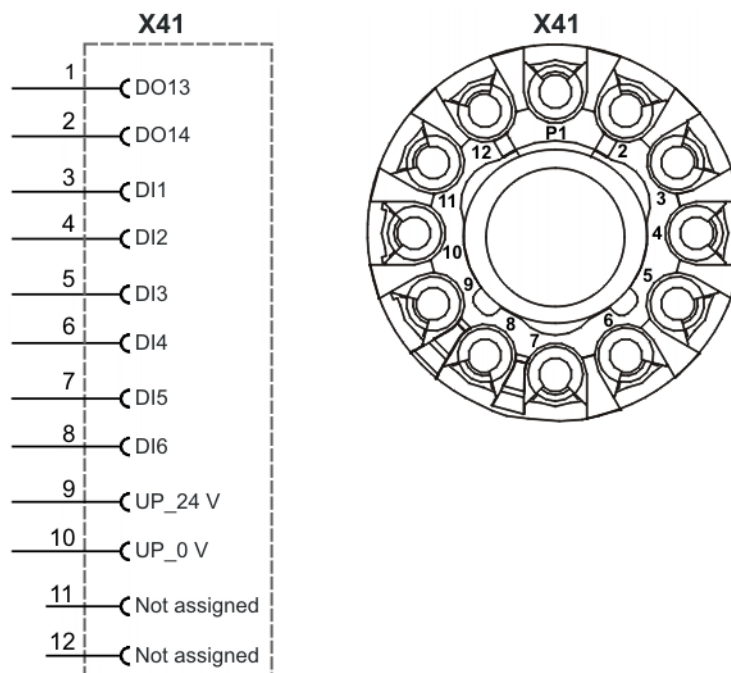
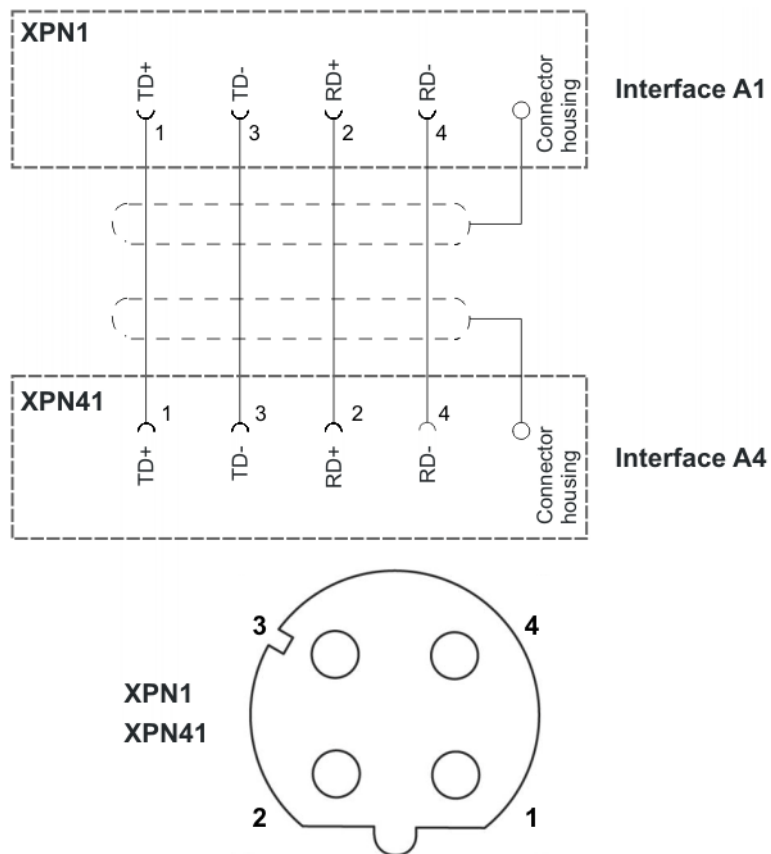

Fig. 6-11: Wiring diagram, connection X41

### Connection XPN41



**Fig. 6-12: Wiring diagram, connection XPN41**

A SAISM-4/8S-M12 4P D-ZF connector from Weidmüller is required for connection XPN41.

### Connection AIR2

Customer-specific air connection with the following values:

Designation	Limit values
Max. pressure	7 bar
Vacuum	Atmospheric pressure minus 0.95 bar



## 7 Transportation

### 7.1 Transporting the manipulator

**Description** Move the robot into its transport position each time it is transported. It must be ensured that the robot is stable while it is being transported. The robot must remain in its transport position until it has been fastened to the foundation. Before the robot is lifted, it must be ensured that it is free from obstructions. Remove all transport safeguards, such as nails and screws, in advance. First remove any corrosion or glue on contact surfaces.

**Transport position** The robot must be in the transport position before it can be transported (>>> Fig. 7-1 ). The robot is in the transport position when the axes are in the following positions:

Axis	A1	A2	A3	A4	A5	A6
Angle	0°	-105°	+156°	0°	+120°	0°

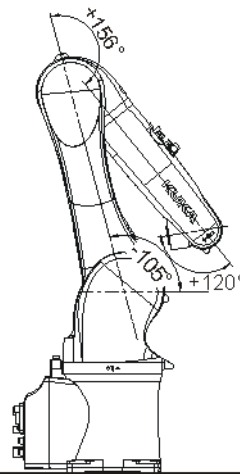
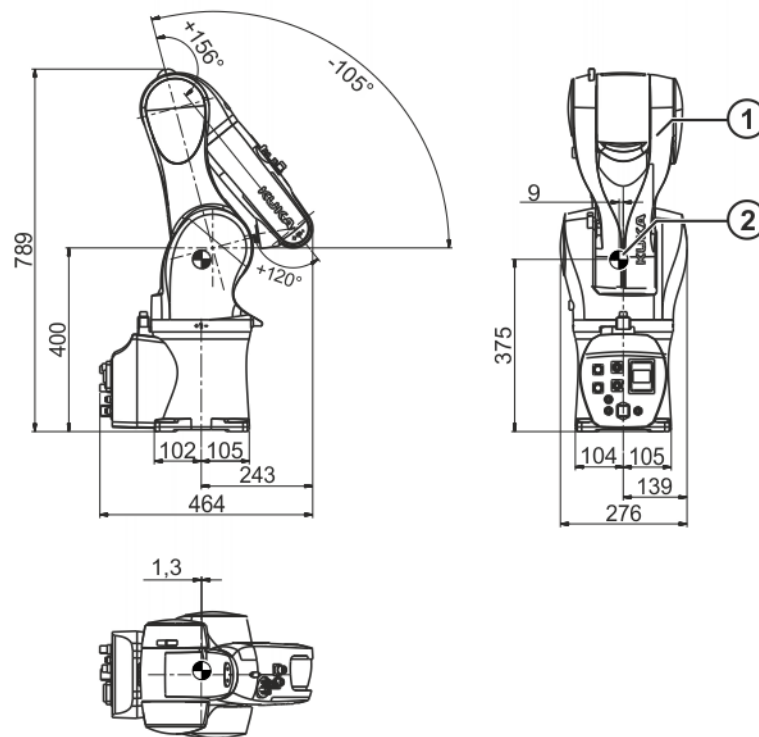

**Fig. 7-1: Transport position**

**Transport dimensions** The transport dimensions for the robot can be noted from the following figures. The position of the center of gravity and the weight vary according to the specific configuration. The specified dimensions refer to the robot without equipment.

The following transport dimensions (>>> Fig. 7-2 ) are valid for the robots:

- KR 6 R700 sixx
- KR 6 R700 sixx W
- KR 6 R700 sixx C



**Fig. 7-2: Transport dimensions**

1 Robot

2 Center of gravity

The following transport dimensions (>>> Fig. 7-3 ) are valid for the robots:

- KR 6 R900 sixx
- KR 6 R900 sixx W
- KR 6 R900 sixx C
- KR 10 R900 sixx
- KR 10 R900 sixx W
- KR 10 R900 sixx C

Dimensions: mm

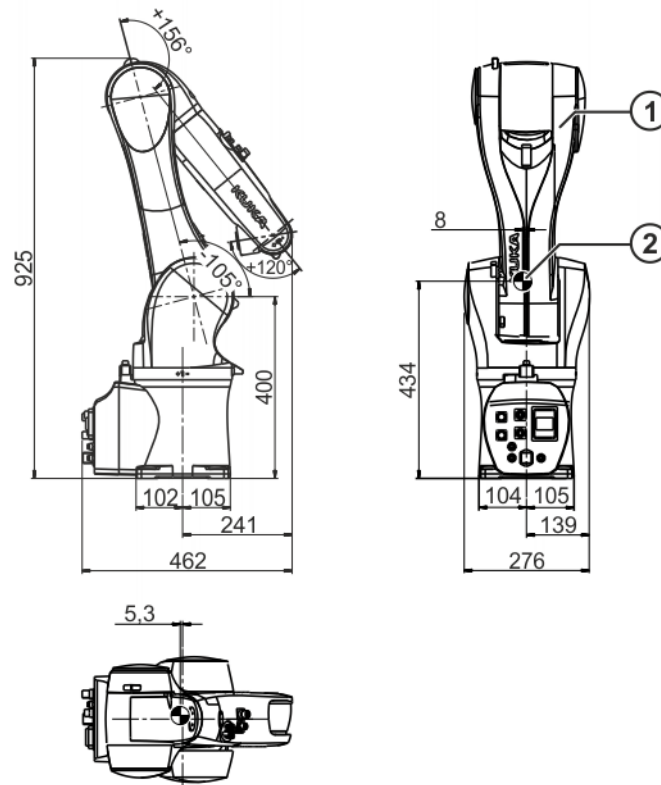

**Fig. 7-3: Transport dimensions**

1 Robot

2 Center of gravity

The following transport dimensions (>>> Fig. 7-4 ) are valid for the robots:

- KR 10 R1100 sixx
- KR 10 R1100 sixx W
- KR 10 R1100 sixx C

Maße / Dimensions: mm

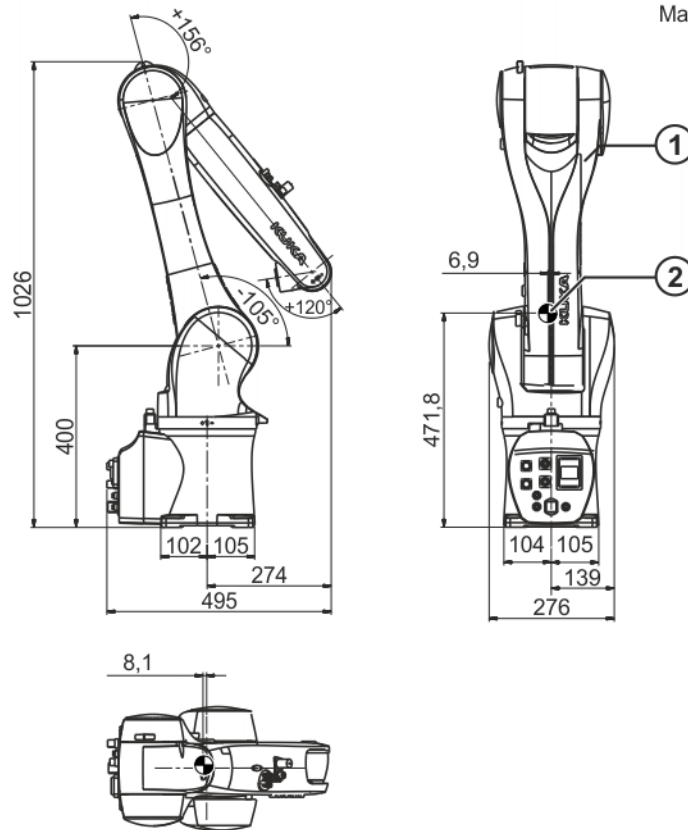

Fig. 7-4: Transport dimensions

1 Robot

2 Center of gravity

**Transportation using lifting tackle**

**WARNING** Use of unsuitable handling equipment may result in damage to the robot or injury to persons. Only use authorized handling equipment with a sufficient load-bearing capacity. Only transport the robot in the manner specified here.

The robot is transported using lifting tackle (>>> Fig. 7-5 ). The robot must be in the transport position. The loops of the lifting tackle are passed around the link arm and rotating column. All ropes must be long enough and must be routed in such a way that the robot is not damaged. Installed tools and pieces of equipment can cause undesirable shifts in the center of gravity.

**WARNING** The robot may tip during transportation. Risk of personal injury and damage to property. If the robot is being transported using lifting tackle, special care must be exercised to prevent it from tipping. Additional safeguarding measures must be taken. It is forbidden to pick up the robot in any other way using a crane!



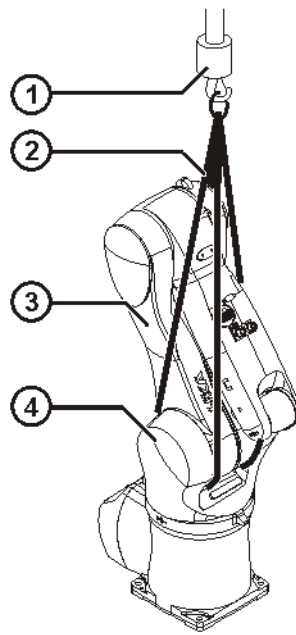

---

**Fig. 7-5: Transportation using lifting tackle**

- |   |                |   |                 |
|---|----------------|---|-----------------|
| 1 | Crane          | 3 | Link arm        |
| 2 | Lifting tackle | 4 | Rotating column |



## 8 Start-up and recommissioning

### 8.1 Installing the mounting base

**Description** These instructions apply to the “mounting base with centering” variant. The robot is fastened to an appropriate concrete foundation using a bedplate and resin-bonded anchors.

If the surface of the concrete foundation is not sufficiently smooth and even, the differences must be evened out with a suitable leveling compound.

When using a Dynamic Set and resin-bonded anchors, use only components and resin capsules from the same manufacturer. No diamond tools or core drills may be used for drilling the anchor holes; for preference, drilling tools supplied by the anchor manufacturer are to be used. Observe also the manufacturer's instructions for the use of resin-bonded anchors.

- Precondition**
- The concrete foundation must have the required dimensions and cross-section.
  - The surface of the foundation must be smooth and even.
  - The mounting base assembly must be complete.
  - Have the leveling compound readily at hand.

**Special tools** The following special tools are required:

- Drill with a  $\varnothing$  14 mm bit
- Setting tool approved by the anchor manufacturer

- Procedure**
1. Determine the position of the plate on the foundation in relation to the working envelope.
  2. Set the bedplate down on the foundation in its installation position.

**NOTICE**

If the bedplate is not fully seated on the concrete ceiling, fill the gap with leveling compound. To do this, lift the bedplate again and apply sufficient leveling compound to the underside. Then set the bedplate down again and align it, removing any excess leveling compound.

3. Check that the bedplate is horizontal. The maximum permissible deviation is 3°.
4. Allow the leveling compound to cure for about 3 hours. The curing time is longer at temperatures below 293 K (20 °C).
5. Drill 4 anchor holes through the holes of the bedplates into the foundation (>>> Fig. 8-1 ).
6. Clean the anchor holes.
7. Insert 4 resin capsules one after the other.
8. Clamp the setting tool with the chemical anchor rod in the drill and insert it into the anchor hole at max. 750 rpm. The chemical anchor rod is set correctly if the resin is completely mixed and the anchor hole in the concrete is completely filled to the upper edge.

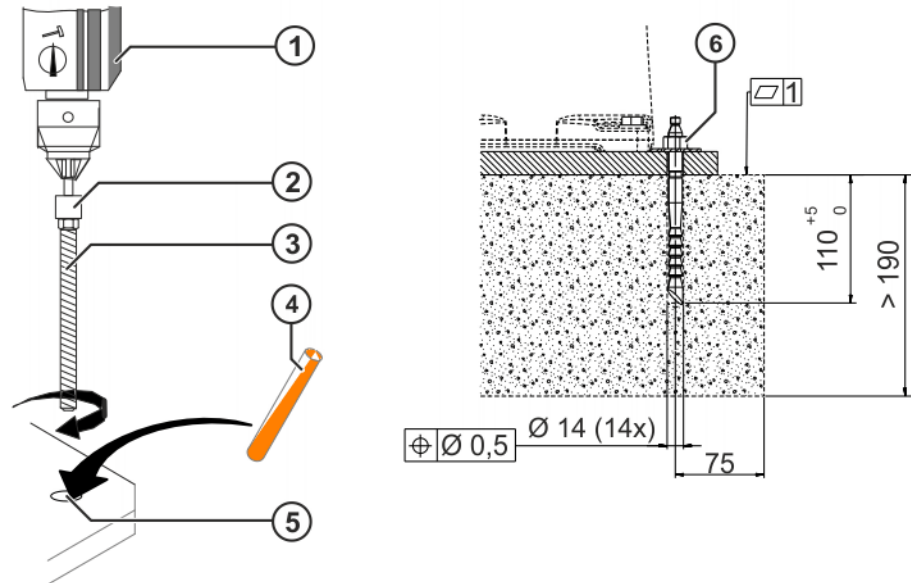

**Fig. 8-1: Installation of resin-bonded anchors**

- |                       |                                |
|-----------------------|--------------------------------|
| 1 Drill               | 4 Resin capsule                |
| 2 Setting tool        | 5 Anchor hole                  |
| 3 Chemical anchor rod | 6 Hexagon nut with lock washer |
9. Repeat step 8 for all chemical anchors.  
 10. Allow the resin to cure. See table, or as specified by manufacturer. These values are guide values.

Temperature	Time
≥293 K (+20 °C)	20 minutes
≥283 K (+10 °C)	30 minutes
≥273 K (0 °C)	1 hour

11. Fit 4 lock washers and 4 hexagon nuts one after the other. Tighten the hexagon nuts with a torque wrench in diagonally opposite sequence. Gradually increase the tightening torque to a value of 80 Nm.  
 12. Retighten the hexagon nuts after 100 hours of operation.  
 The mounting base is now ready for the robot to be installed.

## 8.2 Installing the machine frame mounting assembly

**Description** The machine frame mounting is used for installing robots on a steel structure prepared by the customer.

- Precondition**
- The mounting surface has been prepared as shown in the diagram (>>> Fig. 6-5).
  - The substructure has been checked for sufficient safety.
  - The machine frame mounting assembly is complete.

- Procedure**
1. Clean the mounting surface of the robot (>>> Fig. 8-2).
  2. Check the hole pattern.
  3. Insert 2 stepped pins into the hole pattern.
  4. Provide 4 M10x35 hexagon bolts together with conical spring washers.

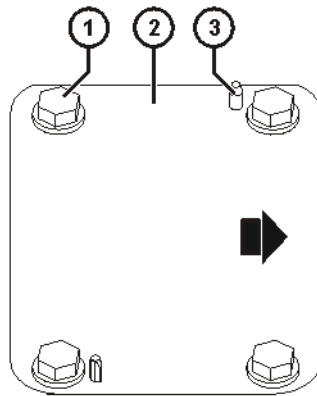

**Fig. 8-2: Installation of the machine frame mounting assembly**

- |                     |               |
|---------------------|---------------|
| 1 Hexagon bolt (4x) | 3 Stepped pin |
| 2 Mounting surface  |               |

The foundation is now ready for the robot to be installed.

### 8.3 Installing a floor-mounted robot

- Description** This description is valid for the installation of floor-mounted robots.
- 4 hexagon bolts with conical spring washers are used for fastening the robot to the bedplate or to a machine frame. A cylindrical pin and a flat-sided pin are provided to ensure correct positioning.
- The installation and start-up of the robot controller, the tools mounted and the applications are not described here.
- Precondition**
- The mounting base is installed.
  - The installation site is accessible with a crane.
  - Any tools or other system components which would hinder the work have been removed.
  - The robot is in the transport position.
  - The connecting cables and ground conductors are routed to the robot and installed.
- Procedure**
1. Check that the pins are undamaged and fitted securely (>>> Fig. 8-3 ).
  2. Bring the robot to the installation site with the crane.
  3. Carefully lower the robot vertically onto the mounting surface. Ensure that an entirely vertical position is maintained in order to prevent damage to the pins.
  4. Insert 4 M10x35 hexagon bolts together with conical spring washers.
  5. Tighten 4 M10x35 hexagon bolts with the torque wrench in diagonally opposite sequence. Gradually increase the tightening torque to 45.0 Nm.
  6. Remove the lifting tackle.
  7. Connect motor cable X30 and data cable X31.
  8. Connect the ground conductor between the robot controller and the robot to the ground conductor connection.
  9. Connect the ground conductor between the system component and the robot to the ground conductor connection.
  10. Check the equipotential bonding in accordance with VDE 0100 and EN 60204-1.



Further information is contained in the operating and assembly instructions of the robot controller.

11. Mount tooling, if present.
12. Retighten the 4 M10x35 hexagon bolts with a torque wrench after 100 hours of operation.

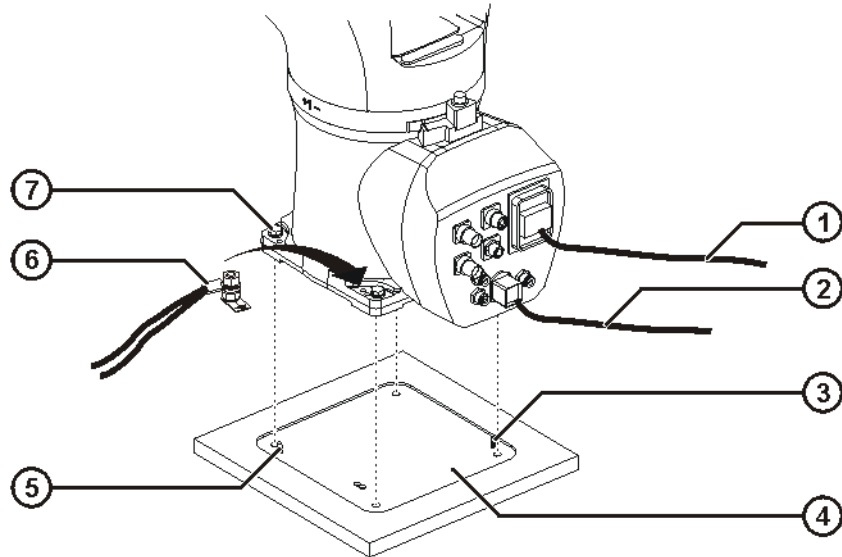

**Fig. 8-3: Installing floor-mounted robots**

- |   |                  |   |                  |
|---|------------------|---|------------------|
| 1 | Motor cable      | 5 | Cylindrical pin  |
| 2 | Data cable       | 6 | Ground conductor |
| 3 | Flat-sided pin   | 7 | Hexagon bolt     |
| 4 | Mounting surface |   |                  |

Put the robot system into operation in accordance with the “Start-up” chapter of the operating and programming instructions for the KUKA System Software (KSS) and the “Start-up” chapter of the operating instructions for the robot controller.

## 8.4 Installing a wall-mounted robot

### Description

This description is valid for the installation of wall-mounted robots with the mounting variant “Machine frame mounting”. For installation on the wall, the robot must be fastened to the Load Lifting Attachment. The robot is fastened to the wall using the Load Lifting Attachment. The Load Lifting Attachment must then be removed.

The installation and start-up of the robot controller, the tools mounted and the applications are not described here.

### Precondition

- The machine frame mounting assembly is installed.
- The installation site is accessible with a crane and fork lift truck.
- Any tools or other system components which would hinder the work have been removed.
- The robot is in the transport position.
- 2 instructed persons are required for performing this task.

### Procedure

1. Bring the robot to the installation site with the crane and set it down.
2. Carefully push the Load Lifting Attachment onto the base frame of the robot from the front (>>> Fig. 8-4 ).

3. Remove the lifting tackle.
4. Fasten the robot to the front of the Load Lifting Attachment with 2 M12x30 Allen screws and washers;  $M_A = 40 \text{ Nm}$ .

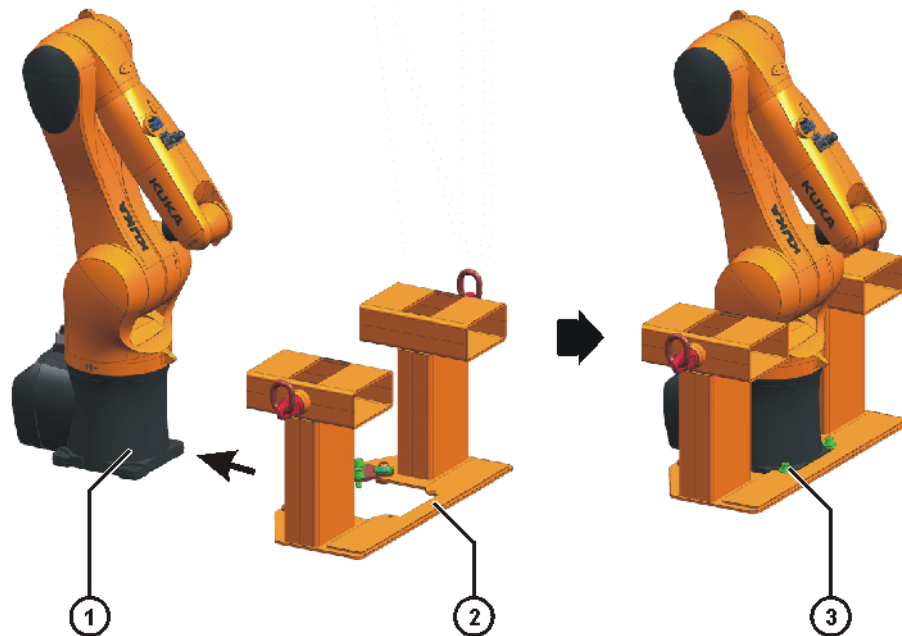

**Fig. 8-4: Pushing on the Load Lifting Attachment and fastening it at the front**

- 1 Base frame
  - 2 Load Lifting Attachment
  - 3 M12x30 Allen screw (front)
5. Position swivel holders on base frame (>>> Fig. 8-5).
  6. Fasten the swivel holders to the rear of the base frame with 2 M12x30 Allen screws and washers;  $M_A = 40 \text{ Nm}$ .
  7. Lock the swivel holders to the Load Lifting Attachment with 2 M12x30 Allen screws and washers.



**Fig. 8-5: Positioning and fastening the swivel holders**

- 1 Swivel holder
- 2 M12x30 Allen screw (rear)
- 3 M12x30 Allen screw (locking screw)

8. Attach lifting tackle to the 2 rotating swivel eyebolts on the Load Lifting Attachment and to the crane.
9. Person 1:  
Slowly and carefully lift the robot with the crane.  
Person 2:  
Secure the robot against toppling during the lifting operation.

**WARNING**

Ensure that the robot does not topple during the lifting operation. Serious injuries and damage to property may otherwise result.

10. Slowly rotate the robot through 90°. The arm must point downward.
11. Lift the Load Lifting Attachment with a fork lift truck (>>> Fig. 8-6 ).  
The fork lift truck must remain in the fork slots of the Load Lifting Attachment during installation in order to prevent slipping.

**NOTICE**

When picking up the Load Lifting Attachment with the fork lift truck, the width of the fork slots (140 mm) must be taken into consideration. Damage to property may otherwise result.

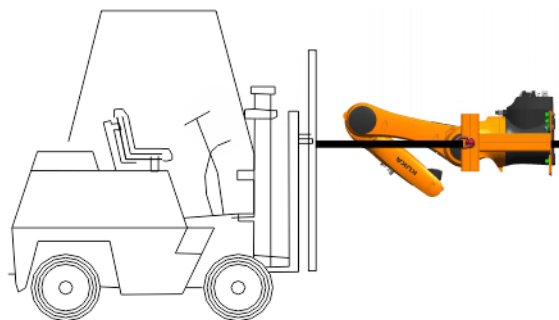

**Fig. 8-6: Lifting the Load Lifting Attachment with a fork lift truck**

12. Position the robot on the wall using the fork lift truck. Ensure that an entirely horizontal position is maintained in order to prevent damage to the pins.
13. Unscrew 2 M12x30 Allen screws (top Allen screws) and washers from the top of the base frame (>>> Fig. 8-7 ).
14. Unscrew 2 M12x30 Allen screws (locking screws) and washers from the Load Lifting Attachment.



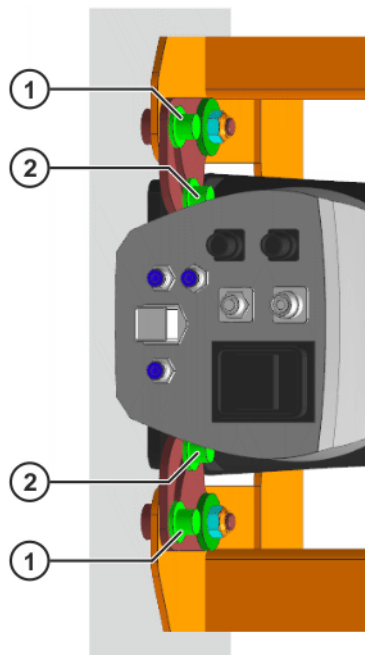

**Fig. 8-7: Removing the top screws**

- 1 M12x30 Allen screw (top)
- 2 M12x30 Allen screw (locking screw)

15. Rotate the swivel holders outwards (>>> Fig. 8-8 ).

16. Fasten the robot to the wall with 2 M10x35 hexagon bolts (top hexagon bolts) and washers at the top.

Tighten the hexagon bolts alternately with torque wrench. Gradually increase the tightening torque to 45 Nm.

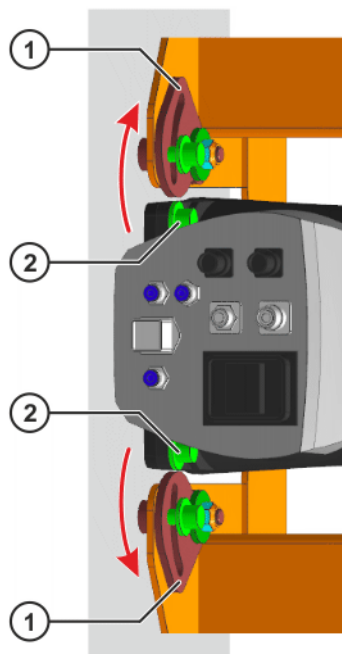
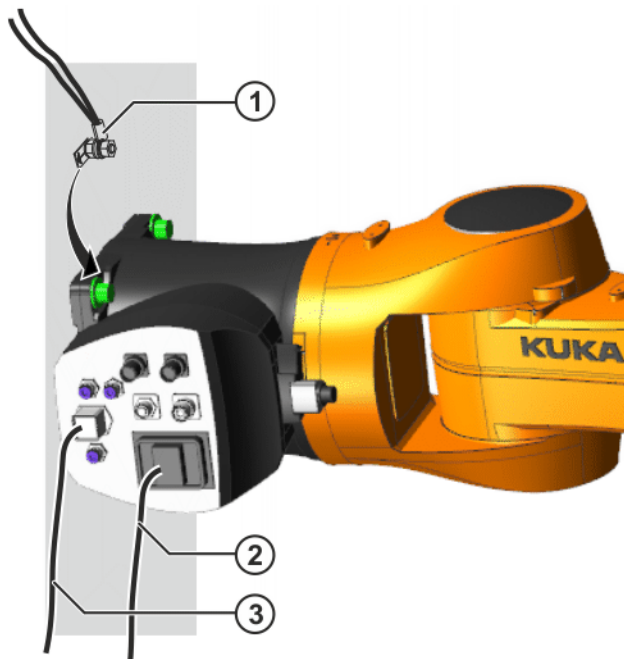

**Fig. 8-8: Rotating the swivel holders outwards**

- 1 Swivel holder
- 2 M10x35 hexagon bolt (top)

17. Unscrew 2 M12x30 Allen screws (bottom Allen screws) and washers from the bottom of the base frame.

18. Carefully separate the Load Lifting Attachment from the bottom of the base frame with the fork lift truck.
19. Fasten the robot to the wall with 2 M10x35 hexagon bolts and washers on the bottom of the base frame.  
Tighten the hexagon bolts alternately with torque wrench. Gradually increase the tightening torque to 45 Nm.
20. Connect motor cable X30 and data cable X31 (>>> Fig. 8-9 ).
21. Connect the ground conductor between the robot controller and the robot to the ground conductor connection.



**Fig. 8-9: Connecting the cables**

- |   |                  |   |            |
|---|------------------|---|------------|
| 1 | Ground conductor | 3 | Data cable |
| 2 | Motor cable      |   |            |

22. Check the equipotential bonding in accordance with VDE 0100 and EN 60204-1.



Further information is contained in the operating and assembly instructions of the robot controller.

23. Connect the ground conductor between the system component and the robot to the ground conductor connection.
24. Mount tooling, if present.
25. Retighten the 4 hexagon bolts with a torque wrench after 100 hours of operation.

Put the robot system into operation in accordance with the "Start-up" chapter of the operating and programming instructions for the KUKA System Software (KSS) and the "Start-up" chapter of the operating instructions for the robot controller.

## 8.5 Installing a ceiling-mounted robot

### Description

This description is valid for the installation of ceiling-mounted robots. The mounting base or machine frame mounting assembly is used for this purpose. For installation on the ceiling, the robot must be fastened to the Load Lifting

Attachment. The robot is fastened to the ceiling using the Load Lifting Attachment. The Load Lifting Attachment must then be removed.

The installation and start-up of the robot controller, the tools mounted and the applications are not described here.

### Precondition

- The machine frame mounting assembly is installed.
- The installation site is accessible with a crane and fork lift truck.
- Any tools or other system components which would hinder the work have been removed.
- The robot is in the transport position.
- 2 instructed persons are required for performing this task.

### Procedure

1. Bring the robot to the installation site with the crane and set it down.
2. Carefully push the Load Lifting Attachment onto the base frame of the robot from the front ( >>> Fig. 8-10 ).
3. Remove the lifting tackle.
4. Fasten the robot to the front of the Load Lifting Attachment with 2 M12x30 Allen screws and washers;  $M_A = 40.0 \text{ Nm}$ .

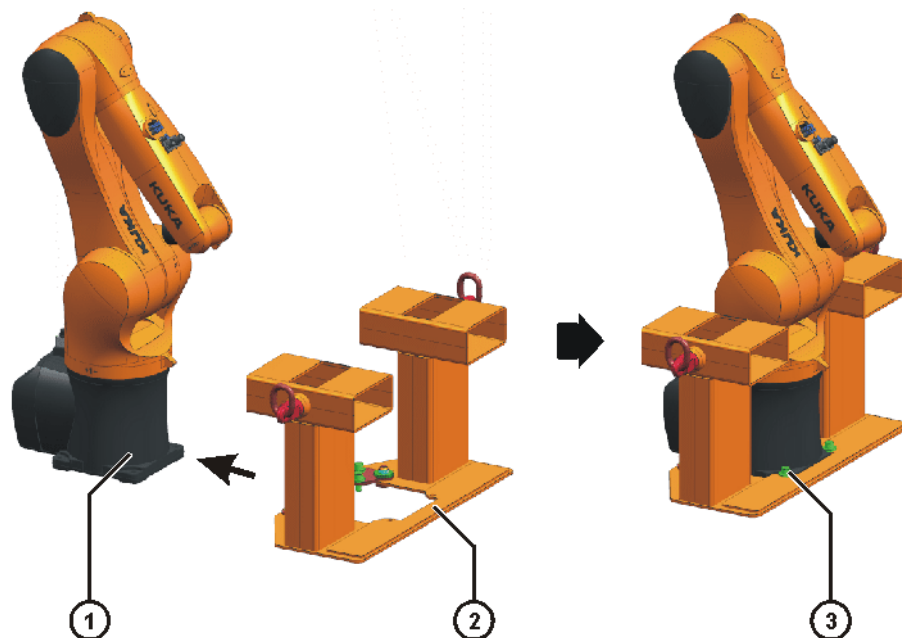

**Fig. 8-10: Pushing on the Load Lifting Attachment and fastening it at the front**

- 1 Base frame
  - 2 Load Lifting Attachment
  - 3 M12x30 Allen screw (front)
5. Position swivel holders on base frame ( >>> Fig. 8-11 ).
  6. Fasten the swivel holders to the rear of the base frame with 2 M12x30 Allen screws and washers;  $M_A = 40.0 \text{ Nm}$ .
  7. Lock the swivel holders to the Load Lifting Attachment with 2 M12x30 Allen screws and washers.



**Fig. 8-11: Positioning and fastening the swivel holders**

- 1 Swivel holder
  - 2 M12x30 Allen screw (rear)
  - 3 M12x30 Allen screw (locking screw)
8. Attach lifting tackle to the 2 rotating swivel eyebolts on the Load Lifting Attachment and to the crane.
  9. Person 1:  
Slowly and carefully lift the robot with the crane.  
Person 2:  
Secure the robot against toppling during the lifting operation.

**WARNING** Ensure that the robot does not topple during the lifting operation. Serious injuries and damage to property may otherwise result.

10. Slowly rotate the robot through 180° and lower it.
11. Lift the Load Lifting Attachment with a fork lift truck (>>> Fig. 8-12 ).  
The fork lift truck must remain in the fork slots of the Load Lifting Attachment during installation in order to prevent slipping.

**NOTICE** When picking up the Load Lifting Attachment with the fork lift truck, the width of the fork slots (140 mm) must be taken into consideration. Damage to property may otherwise result.

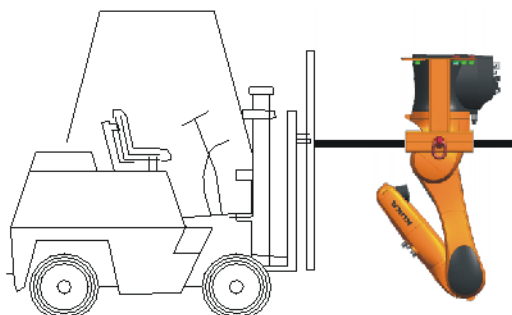

**Fig. 8-12: Lifting the Load Lifting Attachment with a fork lift truck**

12. Position the robot on the ceiling using the fork lift truck. Ensure that an entirely vertical position is maintained in order to prevent damage to the pins.
13. Unscrew 2 M12x30 Allen screws (rear Allen screws) and washers from the rear of the base frame (>>> Fig. 8-13 ).

14. Unscrew 2 M12x30 Allen screws (locking screws) and washers from the Load Lifting Attachment.

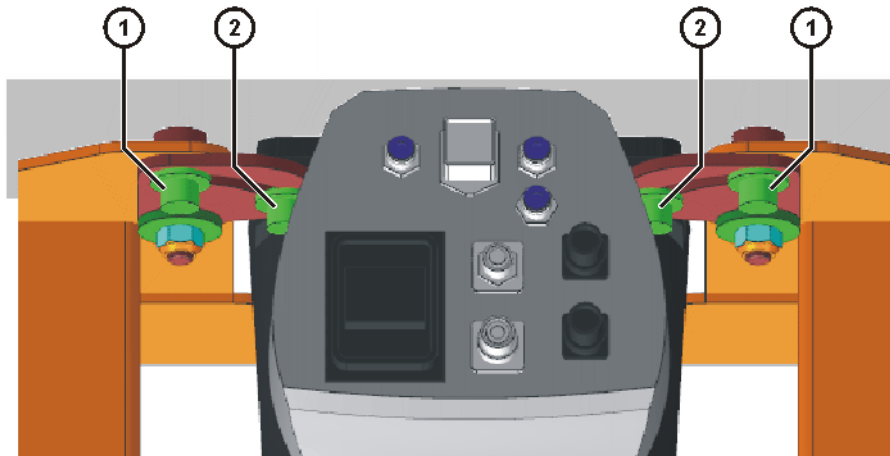

**Fig. 8-13: Removing screws from the rear**

- 1 M12x30 Allen screw (rear)
- 2 M12x30 Allen screw (locking screw)

15. Rotate the swivel holders outwards (>>> Fig. 8-14 ).
16. Fasten the robot to the ceiling with 2 M10x35 hexagon bolts (rear hexagon bolts) and washers at the rear.
- Tighten the hexagon bolts alternately with torque wrench. Gradually increase the tightening torque to 45.0 Nm.

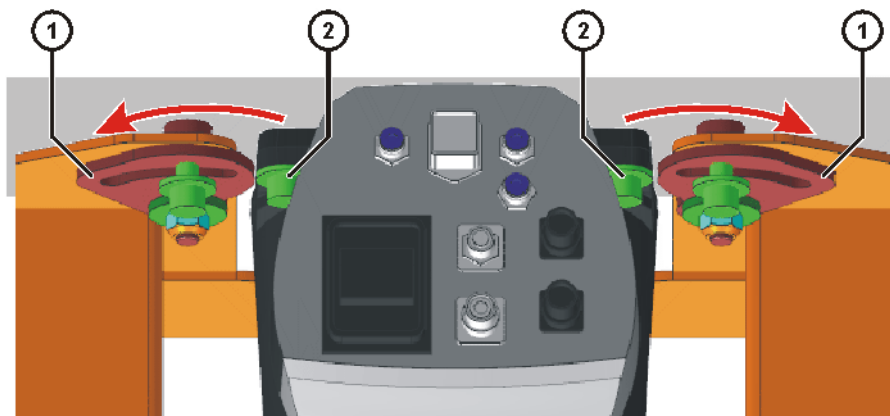

**Fig. 8-14: Rotating the swivel holders outwards**

- 1 Swivel holder
- 2 M10x35 hexagon bolt (rear)

17. Unscrew 2 M12x30 Allen screws (front Allen screws) and washers from the front of the base frame.
18. Carefully push the Load Lifting Attachment down from the back of the base frame with the fork lift truck.
19. Fasten the robot to the ceiling with 2 M10x35 hexagon bolts and washers at the front of the base frame.
- Tighten the hexagon bolts alternately with torque wrench. Gradually increase the tightening torque to 45.0 Nm.
20. Connect motor cable X30 and data cable X31 (>>> Fig. 8-15 ).
21. Connect the ground conductor between the robot controller and the robot to the ground conductor connection.



**Fig. 8-15: Connecting the cables**

- |   |                  |   |            |
|---|------------------|---|------------|
| 1 | Ground conductor | 3 | Data cable |
| 2 | Motor cable      |   |            |

22. Check the equipotential bonding in accordance with VDE 0100 and EN 60204-1.



Further information is contained in the operating and assembly instructions of the robot controller.

23. Connect the ground conductor between the system component and the robot to the ground conductor connection.

24. Mount tooling, if present.

25. Retighten the 4 M10x35 hexagon bolts with a torque wrench after 100 hours of operation.

Put the robot system into operation in accordance with the “Start-up” chapter of the operating and programming instructions for the KUKA System Software (KSS) and the “Start-up” chapter of the operating instructions for the robot controller.

## 8.6 Description of the connecting cables

### Configuration

The connecting cables are used to transfer power and signals between the robot controller and the robot.

The connecting cables comprise:

- Motor cable
- Data cable
- CAT5 data cable (optional)
- Connecting cable, external axes A7 and A8 (optional)
- Ground conductor (optional)

### Interface

For connection of the connecting cables between the robot controller and the robot, the following connectors are available at the interfaces:

Cable designation	Connector designation robot controller - robot	Interface with robot
Motor cable	X20 - X30	Han Yellock 30
Data cable	X21 - X31	Han Q12
CAT5 data cable (can be ordered as an option)	X65/X66 - XPN1	M12 connector
Connecting cable, external axes A7 and A8 (can be ordered as an option)	XP7 - XP7.1 XP8 - XP8.1	Connector M17 in each case
Ground conductor, equipotential bonding (can be ordered as an option)		Ring cable lug M4

Only resolvers can be connected to the connections XP7.1 and XP8.1.



For the connecting cables, a ground conductor is always required to provide a low-resistance connection between the robot and the control cabinet in accordance with DIN EN 60204. The ground conductor is not part of the scope of supply and can be ordered as an option. The connection must be made by the customer. The tapped holes for connecting the ground conductor are located on the base frame of the robot.

#### Standard connecting cable

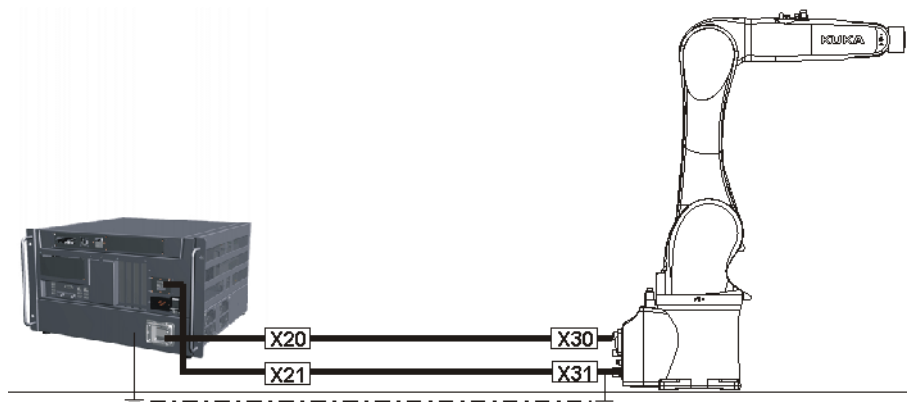
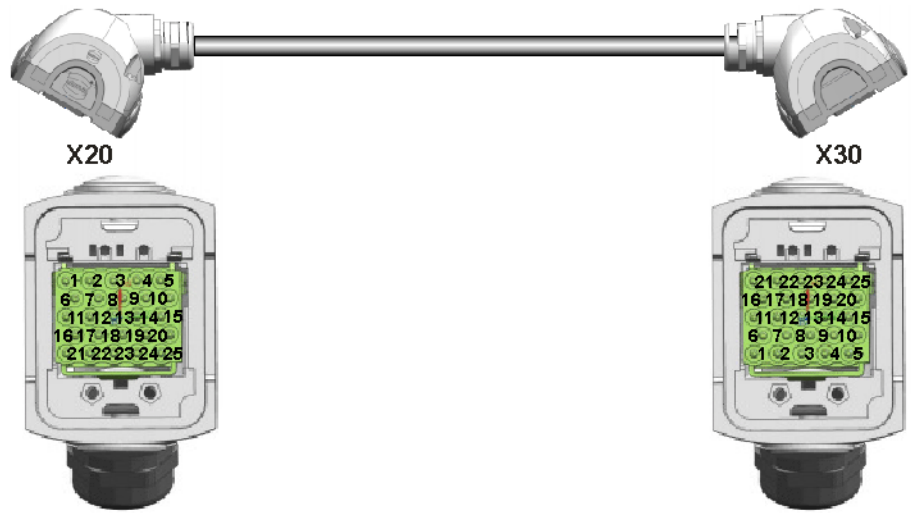

Fig. 8-16: Connecting cables, overview



Wiring diagram

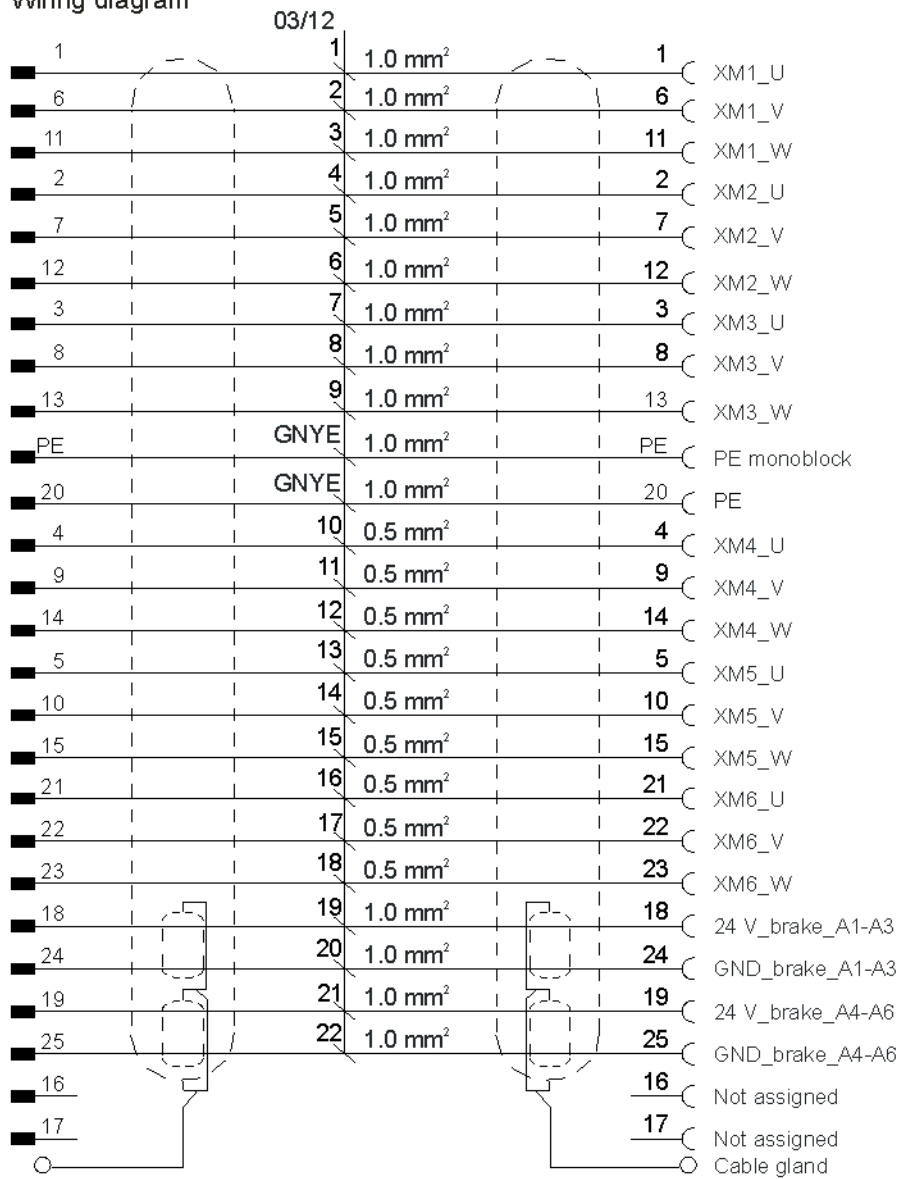

Fig. 8-17: Connecting cable, motor cable, X20 - X30



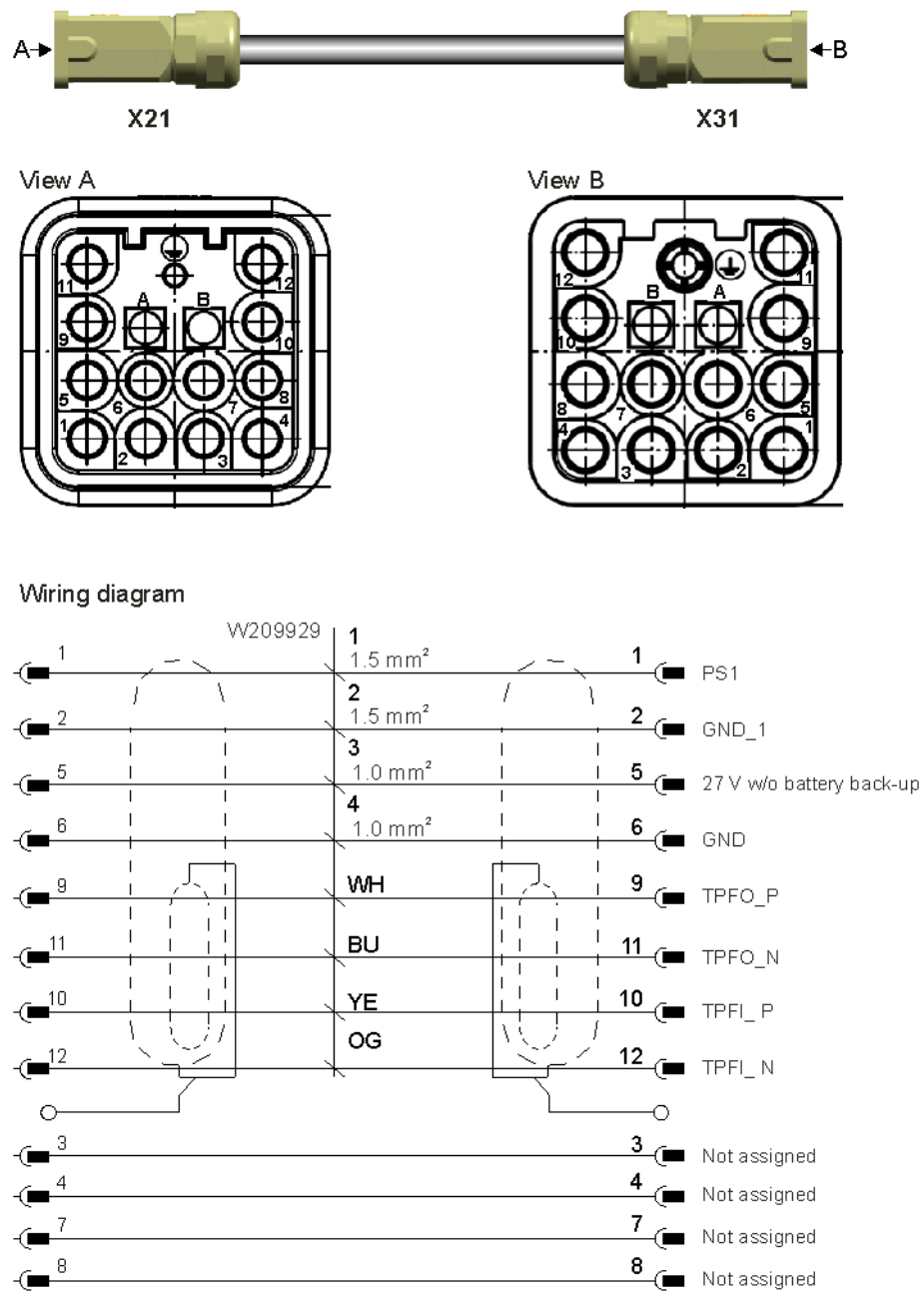

Fig. 8-18: Connecting cable, data cable X21 - X31

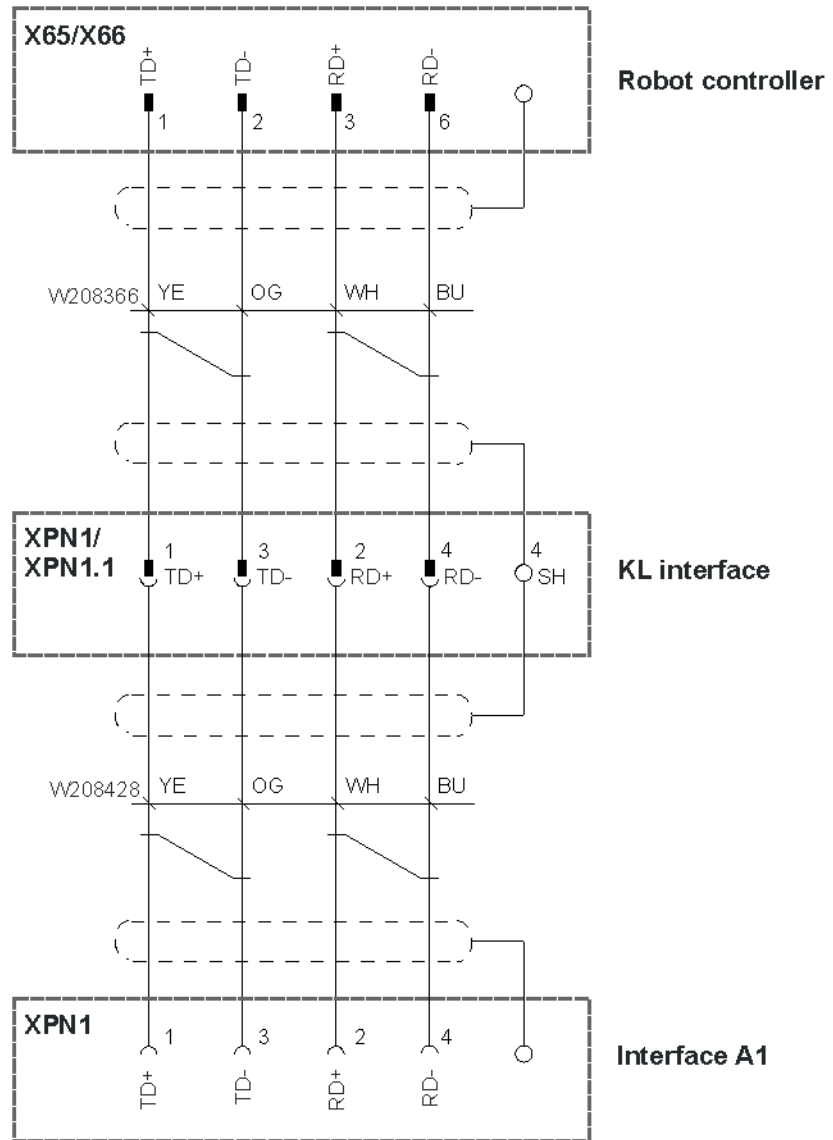

Fig. 8-19: Connecting cable, data cable CAT5 X65/X66 - XPN1

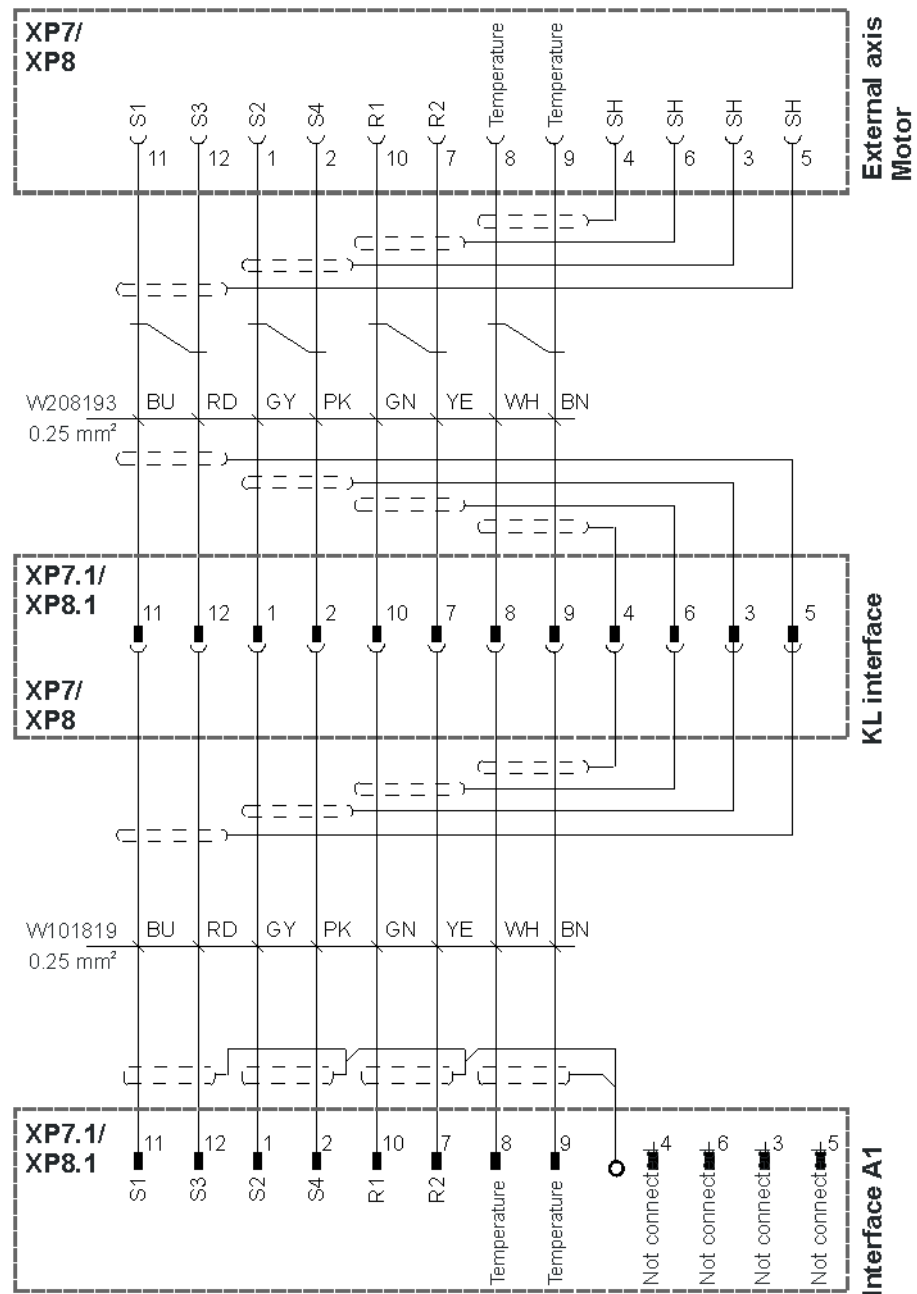

Fig. 8-20: Connecting cable, external axes A7 and A8

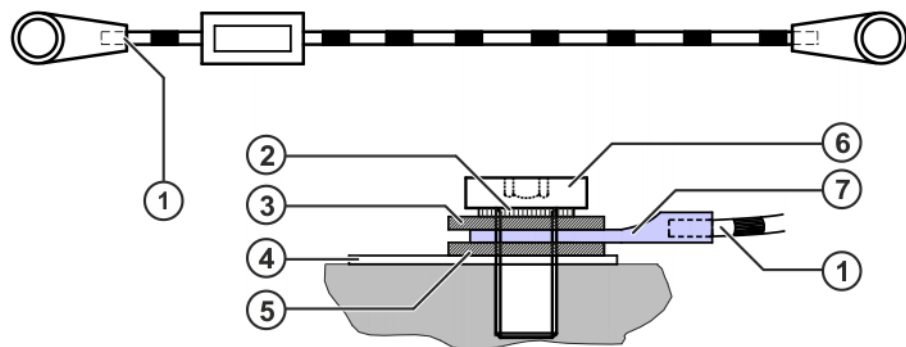

Fig. 8-21: Connecting cable, ground conductor

- 1 Ground conductor
- 2 Lock washer

- 3 Conical spring washer
- 4 Ground plate
- 5 Plain washer
- 6 M4x12 Allen screw
- 7 Ground conductor connection, M4 ring cable lug

## 8.7 Moving the manipulator without drive energy

**Description** The brake release device (optional) can be used for moving the manipulator after an accident or malfunction without drive energy.

This option is only for use in exceptional circumstances and emergencies, e.g. for freeing people.

**Precondition**

- The robot controller must be switched off and secured (e.g. with a padlock) to prevent unauthorized persons from switching it on again.

### Procedure

 **WARNING** Use of the brake release device may result in unexpected robot motions, especially sagging of the axes. During use of the brake release device, attention must be paid to motion of this kind in order to be able to prevent physical injuries or damage to property. Standing under moving axes is not permitted.

 **SAFETY INSTRUCTIONS** The following procedure must be followed exactly!

1. Unplug motor cable X30 on the robot.
2. Plug connector X20 into the brake release device and connector X30 into the robot.
3. Plug connector X1 of the hand-held device into the brake release device.
4. Select the brakes to be released (main axes, wrist axes) via the selection switch on the brake release device.
5. Press the button on the hand-held device.

The brakes of the main axes or wrist axes are released and the robot can be moved manually.



Further information about the brake release device can be found in the documentation for the brake release device.

## 9 Maintenance

### 9.1 Maintenance symbols

#### Maintenance symbols



Oil change



Lubricate with grease gun



Lubricate with brush



Tighten screw/nut



Check component, visual inspection



Replace toothed belts



Check toothed belt tension

### 9.2 Maintenance table

#### Description

The table provides an overview of the maintenance work (maintenance intervals, activities, lubrication work) and required lubricants applicable to this robot.

The maintenance intervals given in the table are valid for the operating conditions specified in the technical data. KUKA Roboter GmbH must be consulted in the case of discrepancies.



Further information can be found in the section "Information for planning" (>>> 6.1 "Information for planning" Page 105).

#### Precondition

- The maintenance points must be freely accessible.
- Remove the tools and any additional items of equipment if they impede maintenance work.



Unintentional robot motions can cause injuries and damage to property. If work is carried out on an operational robot, the robot must be secured by activating the EMERGENCY STOP device.

Warn all persons concerned before starting to put it back into operation.

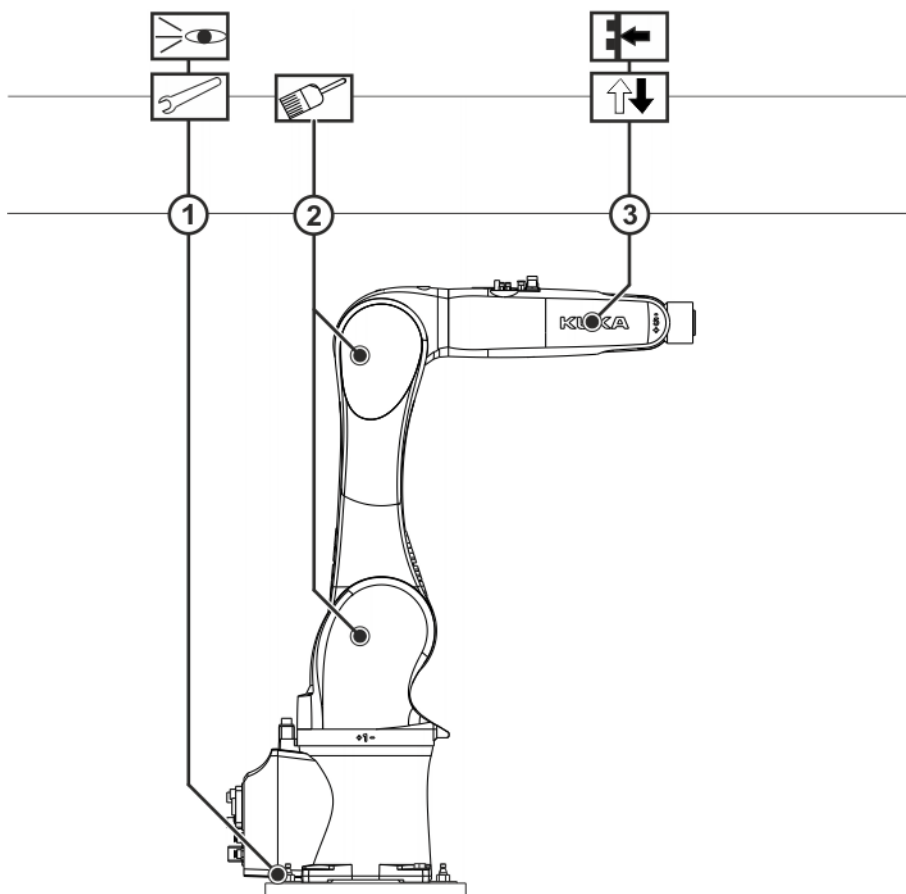

Fig. 9-1: Maintenance work

Interval	Item	Activity	Lubricant
100 h*	1	Check the tightening torque of the 4 holding-down bolts on the mounting base.  $M_A = 45 \text{ Nm}$  * Once only, after initial start-up or recommissioning.	-
1 year	1	If using a mounting base, check the tightening torque of the 4 fastening screws.  $M_A = 45 \text{ Nm}$	-
5,000 h or 1 year at the latest	2	Grease the inside of covers A2 and A3.  (>>> 9.3 "Greasing the inside of covers A2 and A3" Page 143)	Obeen FS2 Art. No. 00-134-846  10 g
5,000 h or 1 year at the latest	3	Exchange toothed belts on A5 and A6.  (>>> 9.4 "Removing and installing toothed belts A5 and A6" Page 144)	-

### 9.3 Greasing the inside of covers A2 and A3

**Description** The inside of covers A2 and A3 must be greased with Obeen FS2.

**Precondition** ■ Arm and in-line wrist are horizontal.

**WARNING** Unintentional robot motions can cause injuries and damage to property. If work is carried out on an operational robot, the robot must be secured by activating the EMERGENCY STOP device. Warn all persons concerned before starting to put it back into operation.

**CAUTION** The motors reach temperatures during operation which can cause burns to the skin. Contact must be avoided. Appropriate safety precautions must be taken, e.g. protective gloves must be worn.

#### Procedure

1. Remove the following round head screws from cover A2 and take off cover A2 (>>> Fig. 9-2):
  - 3 M4x14-10.9 round head screws
  - 2 M4x25-10.9 round head screws
  - 5 M4x35-10.9 round head screws
2. Remove 7 M3x10-10.9 round head screws from cover A3 and take off cover A3.

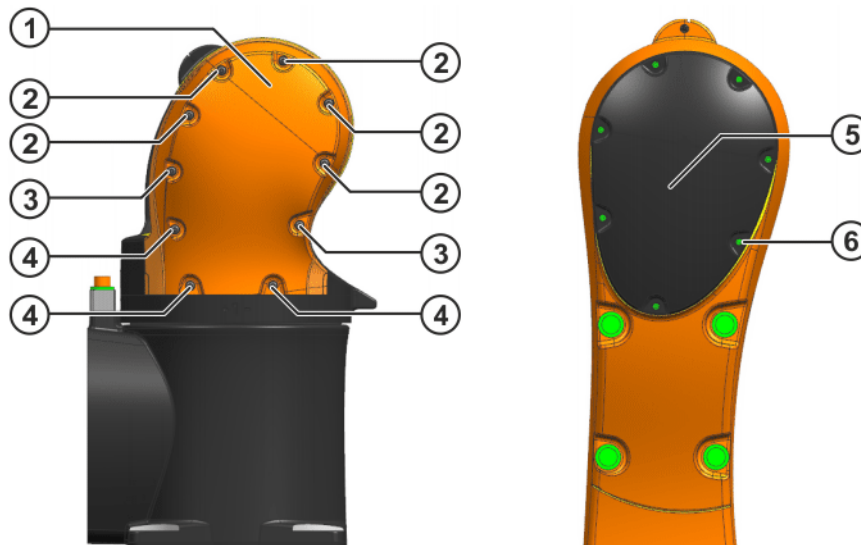

**Fig. 9-2: Removing covers A2 and A3**

- 1 Cover A2
  - 2 M4x35-10.9 round head screws
  - 3 M4x25-10.9 round head screws
  - 4 M4x14-10.9 round head screws
  - 5 Cover A3
  - 6 M3x10-10.9 round head screws
3. Grease the inside of both covers with Obeen FS2.
  4. Fit cover A2 and fasten it with the following screws:
    - 3 round head screws M4x14-10.9;  $M_A = 1.9 \text{ Nm}$
    - 2 round head screws M4x25-10.9;  $M_A = 1.9 \text{ Nm}$
    - 5 round head screws M4x35-10.9;  $M_A = 1.9 \text{ Nm}$

5. Mount cover A3 and fasten it with 7 M3x10-10.9 round head screws;  
 $M_A = 0.8 \text{ Nm}$ .

## 9.4 Removing and installing toothed belts A5 and A6

### Description

The toothed belts of axes 5 and 6 may only be removed and installed together.

### Precondition

- Axis 5 is horizontal.
- No tools are installed on axis 6.

**⚠ WARNING** Unintentional robot motions can cause injuries and damage to property. If work is carried out on an operational robot, the robot must be secured by activating the EMERGENCY STOP device.  
 Warn all persons concerned before starting to put it back into operation.

**⚠ WARNING** If the toothed belt is removed and installed immediately after the robot has stopped operating, surface temperatures are likely to be high and could result in burn injuries; there is also a risk of hands and fingers being pinched or crushed.  
 Protective gloves must be worn.

### Procedure

1. Remove 7 M3x10-10.9 fillister head screws from the cover and take off the cover (>>> Fig. 9-3 ).

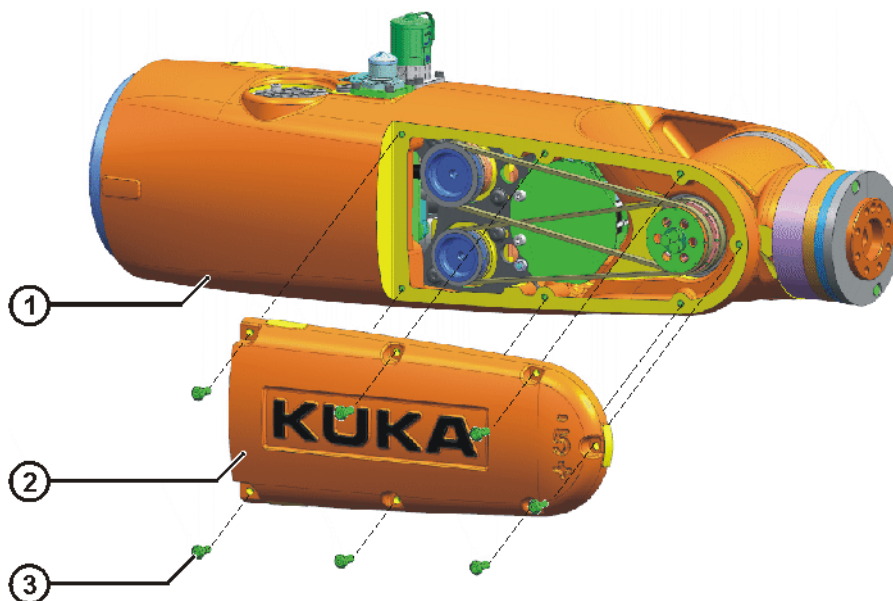
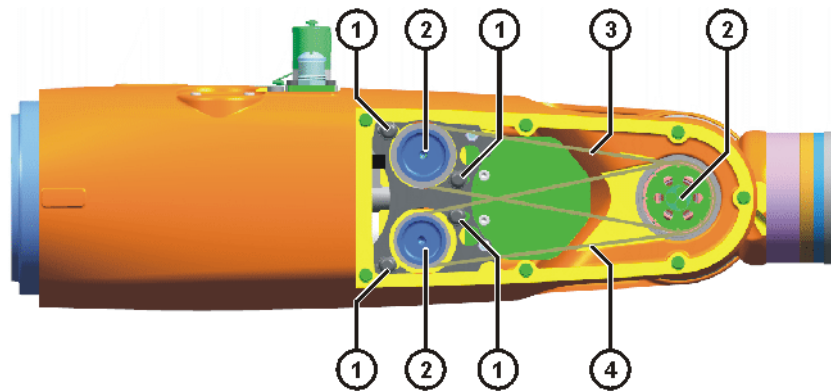

Fig. 9-3: Removing the cover from the in-line wrist – example

- |                 |                        |
|-----------------|------------------------|
| 1 In-line wrist | 3 Fillister head screw |
| 2 Cover         |                        |
2. Slacken 2 M4x10-10.9 fillister head screws on motor A5 and motor A6.  
 (>>> Fig. 9-4 )
  3. Take the old toothed belts A5 and A6 off the pulleys.





**Fig. 9-4: Removing the toothed belt – example**

- |   |                      |   |                 |
|---|----------------------|---|-----------------|
| 1 | Fillister head screw | 3 | Toothed belt A5 |
| 2 | Toothed belt pulley  | 4 | Toothed belt A6 |
4. Fit new toothed belts A5 and A6 in the in-line wrist. Ensure that the toothed belts mesh properly with the toothed belt pinions (>>> Fig. 9-5 ).

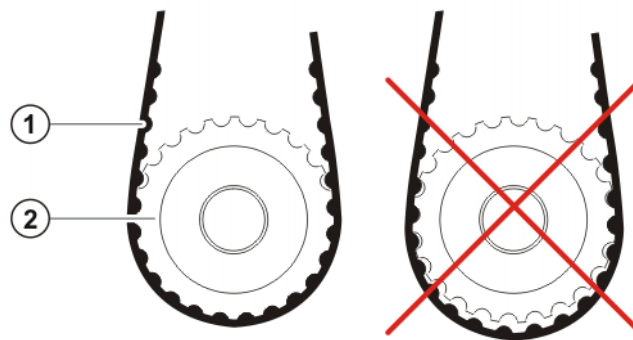

**Fig. 9-5: Toothed belt and toothed belt pinion**

- |   |              |   |                     |
|---|--------------|---|---------------------|
| 1 | Toothed belt | 2 | Toothed belt pinion |
|---|--------------|---|---------------------|
5. Measure and adjust the toothed belt tension.  
(>>> 10.1 "Measuring and adjusting the toothed belt tension for the in-line wrist, A5, A6" Page 147)
6. Mount the cover and fasten it with 7 new M3x10-10.9 fillister head screws;  $M_A = 0.8 \text{ Nm}$ .
7. Carry out mastering of axes 5 and 6.

 Detailed information about mastering is contained in the operating and programming instructions for end users or system integrators.

## 9.5 Cleaning the robot

### Description

The robot must be cleaned in compliance with the instructions given here in order to prevent damage. These instructions only refer to the robot. System components, tools and the robot controller must be cleaned in accordance with the cleaning instructions relevant to them.

The following must be taken into consideration when using cleaning agents and carrying out cleaning work:

- Only use solvent-free, water-soluble cleaning agents.
- Do not use flammable cleaning agents.
- Do not use aggressive cleaning agents.

- Do not use steam or refrigerants for cleaning.
- Do not use high-pressure cleaners.
- It must be ensured that no cleaning agent enters electrical or mechanical system components.
- Personnel protection measures must be taken.

### Precondition

 **WARNING** Unintentional robot motions can cause injuries and damage to property. If work is carried out on an operational robot, the robot must be secured by activating the EMERGENCY STOP device.  
Warn all persons concerned before starting to put it back into operation.

### Procedure

1. Shut down the robot.
2. If necessary, stop adjacent system components and lock them.
3. Remove enclosures if this is necessary in order to carry out the cleaning work.
4. Clean the robot.
5. Fully remove all cleaning agents from the robot.
6. Clean any areas of corrosion and reapply corrosion protection.
7. Remove cleaning agents and equipment from the workspace of the robot.
8. Dispose of cleaning agents in accordance with the pertinent regulations.
9. Install any safety equipment that has been removed and check that it is functioning correctly.
10. Replace any damaged or illegible plates and covers.
11. Put back in place any enclosures that have been removed.
12. Only put fully functional robots and systems back into operation.

## 10 Repair

### 10.1 Measuring and adjusting the toothed belt tension for the in-line wrist, A5, A6

**Description** The toothed belt tension on A5 and A6 is measured and adjusted in the same way. The following description deals with the toothed belt tension for A5.

**Precondition**

- Axis 5 is horizontal.
- No tools are installed on axis 6.

**⚠ WARNING** Unintentional robot motions can cause injuries and damage to property. If work is carried out on an operational robot, the robot must be secured by activating the EMERGENCY STOP device.  
Warn all persons concerned before starting to put it back into operation.

**⚠ CAUTION** If the toothed belt tension is measured and adjusted immediately after the robot has stopped operating, surface temperatures are likely to be high and could result in burn injuries. Protective gloves must be worn.

**Procedure**

1. Remove 7 M3x10-10.9 fillister head screws from the cover and take off the cover (>>> Fig. 10-1 ).

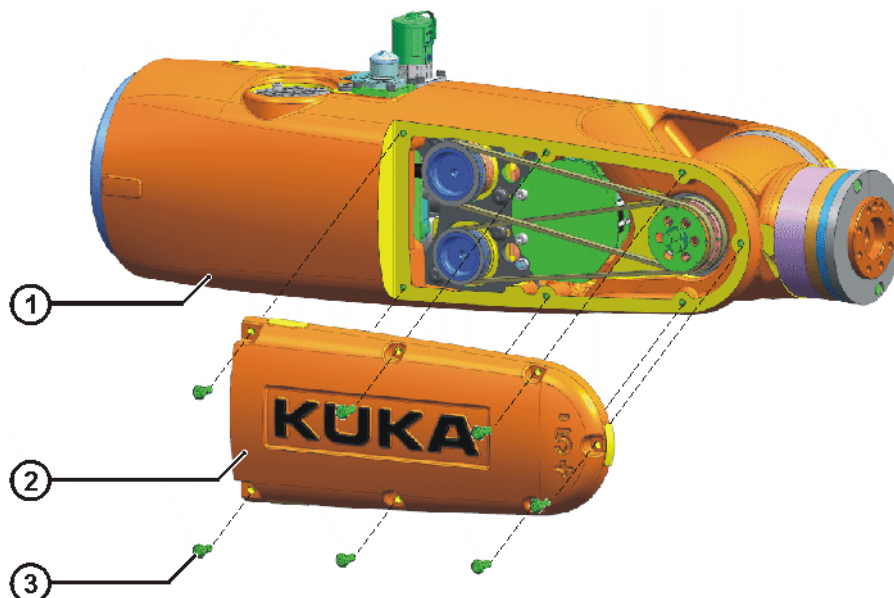

**Fig. 10-1: Removing the cover from the in-line wrist – example**

1 In-line wrist	3 Fillister head screw
2 Cover	

2. Slacken 2 M4x10-10.9 fillister head screws on motor A5 (>>> Fig. 10-2 ).
3. Insert a suitable tool (e.g. screwdriver) into the corresponding aperture in the motor mount and carefully press motor A5 to the left in order to tension toothed belt A5.

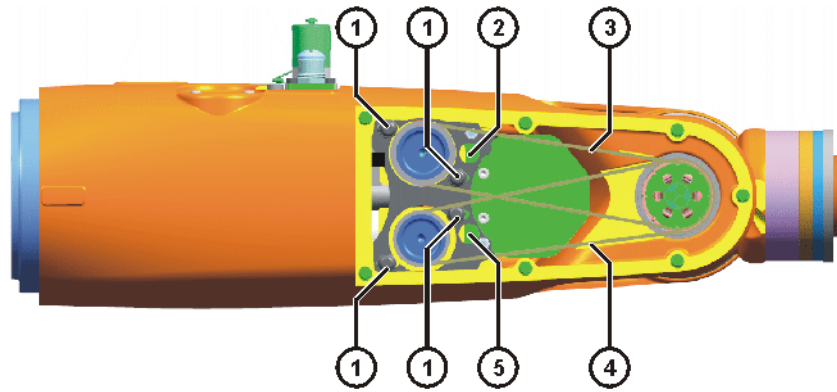

**Fig. 10-2: Tensioning the toothed belt – example**

- 1 Fillister head screw
  - 2 Aperture in motor mount A5
  - 3 Toothed belt A5
  - 4 Toothed belt A6
  - 5 Aperture in motor mount A6
4. Lightly tighten 2 M4x10-10.9 fillister head screws on motor A5.
  5. Switch on the belt tension measuring device (>>> Fig. 10-3 ).
  6. Pluck toothed belt A5 and hold the sensor near its center at a distance of 2 to 3 mm from the vibrating toothed belt. Read the measurement on the belt tension measuring device.

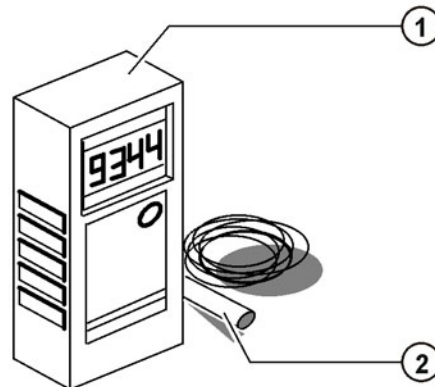

**Fig. 10-3: Belt tension measuring device**

- 1 Belt tension measuring device
- 2 Sensor

Toothed belt tension

In-line wrist	Axis	Toothed belt	Frequency
IW 6 R700	5	AT3/267	305 ± 5 Hz
	6		
IW 6/10 R900	5	AT3/351	205 ± 5 Hz
	6		
IW 10 R1100	5	AT3/351	205 ± 5 Hz
	6		

7. Tighten 2 M4x10-10.9 fillister head screws on motor A5,  $M_A = 1.9 \text{ Nm}$ .
8. Put the robot into operation and move A5 in both directions.
9. Secure the robot by pressing the E-STOP device.
10. Measure the tension of the toothed belt again.

If the value obtained does not correspond to the value in the table, repeat steps 2 to 10.

11. Carry out steps 2 to 10 for toothed belt A6.
12. Mount the cover and fasten it with 7 new M3x10-10.9 fillister head screws;  
 $M_A = 0.8 \text{ Nm}$ .



# 11 Decommissioning, storage and disposal

## 11.1 Decommissioning, floor-mounted robot

**Description** This section describes all the work required for decommissioning the robot if the robot is to be removed from the system. After decommissioning, it is prepared for storage or for transportation to a different location.

Following its removal, the robot can be transported by means of transport tackle and crane (>>> 7 "Transportation" Page 117).

**Precondition**

- The removal site is accessible for transportation with a crane.
- There is no hazard posed by system components.

**⚠ WARNING** When carrying out the following work, the robot must be moved several times between the individual work steps. While work is being carried out on the robot, it must always be secured by activating the EMERGENCY STOP device. Unintentional robot motions can cause injuries and damage to property. If work is carried out on an operational robot that is switched on, the robot must only be moved at reduced velocity. It must be possible to stop the robot at any time by activating an EMERGENCY STOP device. Operation must be limited to what is absolutely necessary. Warn all persons concerned before switching on and moving the robot.

**Procedure**

1. Secure the robot.
2. Remove tools and equipment.
3. Put the robot into operation and move it into the transport position (>>> Fig. 11-1 ).

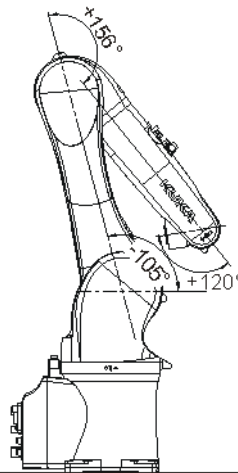

**Fig. 11-1: Transport position**

4. Secure the robot by activating the E-STOP device and then shut down the robot (>>> Fig. 11-2 ).
5. Release and unplug all peripheral connections.
6. Release and unplug the motor cable and data cable connectors.
7. Release and unplug the ground conductor.
8. Attach the lifting tackle.
9. Unscrew and remove the 4 hexagon bolts and conical spring washers.
10. Lift the robot vertically off the mounting surface and transport it away.  
Take care not to damage the two pins when lifting off the robot.

**CAUTION**

If the robot is caught on the mounting surface, it may come free abruptly, endangering persons and property. The robot must stand loosely on the mounting surface; completely remove all fastening materials and any adhesives.

11. Prepare the robot for storage.

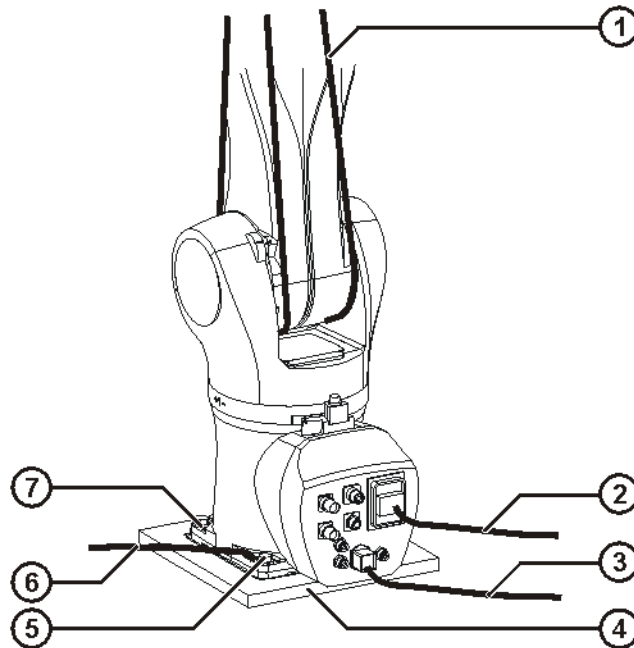

Fig. 11-2: Removing a floor-mounted robot

- |   |                  |   |                  |
|---|------------------|---|------------------|
| 1 | Lifting tackle   | 5 | Hexagon bolt     |
| 2 | Motor cable      | 6 | Ground conductor |
| 3 | Data cable       | 7 | Pin              |
| 4 | Mounting surface |   |                  |

## 11.2 Decommissioning, wall-mounted robot

### Description

This section describes all the work required for decommissioning the wall-mounted robot if the robot is to be removed from the system. After decommissioning, it is prepared for storage or for transportation to a different location.

### Precondition

- The removal site is accessible with a crane and fork lift truck.
- There is no hazard posed by system components.

**WARNING**

When carrying out the following work, the robot must be moved several times between the individual work steps. While work is being carried out on the robot, it must always be secured by activating the EMERGENCY STOP device. Unintentional robot motions can cause injuries and damage to property. If work is carried out on an operational robot that is switched on, the robot must only be moved at reduced velocity. It must be possible to stop the robot at any time by activating an EMERGENCY STOP device. Operation must be limited to what is absolutely necessary. Warn all persons concerned before switching on and moving the robot.

### Procedure

1. Secure the robot.
2. Remove tools and equipment.



3. Put the robot into operation and move it into the transport position (>>> Fig. 11-3 ).

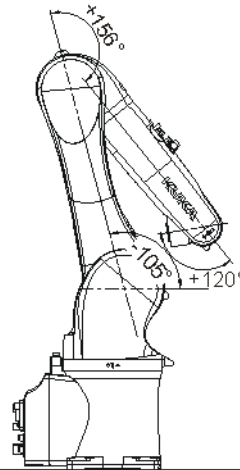
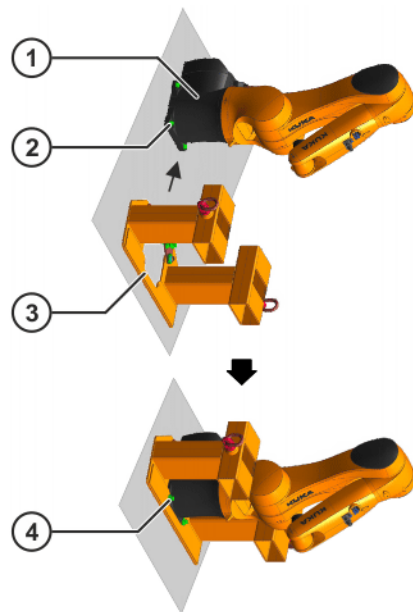

**Fig. 11-3: Transport position**

4. Secure the robot by activating the E-STOP device and then shut down the robot.
5. Release and unplug all peripheral connections.
6. Release and unplug the motor cable and data cable connectors.
7. Release and unplug the ground conductor.
8. Rotate the Load Lifting Attachment so that it can be screwed to the wall-mounted machine.
9. Lift the Load Lifting Attachment with a fork lift truck.  
The fork lift truck must remain in the fork slots of the Load Lifting Attachment during removal in order to prevent slipping.

**NOTICE** When picking up the Load Lifting Attachment with the fork lift truck, the width of the fork slots (140 mm) must be taken into consideration. Damage to property may otherwise result.

10. Unscrew 2 M10x35 hexagon bolts (bottom hexagon bolts) and washers from the bottom of the base frame.
11. Carefully push the Load Lifting Attachment onto the base frame of the robot from underneath (>>> Fig. 11-4 ).
12. Fasten the robot to the Load Lifting Attachment from underneath with 2 M12x30 Allen screws (bottom Allen screws) and washers;  $M_A = 40 \text{ Nm}$ .



**Fig. 11-4: Fastening the Load Lifting Attachment to the robot**

- 1 Base frame
  - 2 M10x35 hexagon bolt (bottom)
  - 3 Load Lifting Attachment
  - 4 M12x30 Allen screw (bottom)
13. Unscrew 2 M10x35 hexagon bolts (top hexagon bolts) and washers from the top of the base frame.
  14. Position swivel holders on base frame (>>> Fig. 11-5 ).
  15. Fasten the swivel holders to the top of the base frame with 2 M12x30 Allen screws and washers;  $M_A = 40 \text{ Nm}$ .
  16. Lock the swivel holders to the Load Lifting Attachment with 2 M12x30 Allen screws (locking screws) and washers.

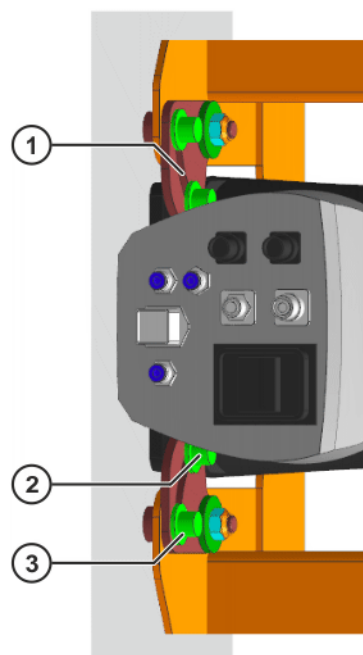

**Fig. 11-5: Positioning and fastening the swivel holders**

- 1 Swivel holder
  - 2 M12x30 Allen screw (top)
  - 3 M12x30 Allen screw (locking screw)
17. Slowly move the robot away from the wall with a fork lift truck.
  18. Attach lifting tackle to the 2 rotating swivel eyebolts on the Load Lifting Attachment and to the crane.
  19. Move the fork lift truck slowly and carefully out of the fork slots of the Load Lifting Attachment.
  20. Person 1:  
Slowly and carefully lower the robot with the crane.  
Person 2:  
Secure the robot against toppling during the lowering operation.

 <b>WARNING</b>	Ensure that the robot does not topple during the lowering operation. Serious injuries and damage to property may otherwise result.
--	--

21. Slowly rotate the robot through 90° and carefully set it down.
22. Unscrew 4 M12x30 Allen screws and washers from the Load Lifting Attachment.
23. Unscrew 2 M12x30 Allen screws and washers from the swivel holders.
24. Rotate the swivel holders outwards.
25. Carefully push the Load Lifting Attachment down from the back of the base frame.
26. Prepare the robot for storage.

### 11.3 Decommissioning, ceiling-mounted robot

**Description** This section describes all the work required for decommissioning the ceiling-mounted robot if the robot is to be removed from the system. After decommissioning, it is prepared for storage or for transportation to a different location.

**Precondition**

- The removal site is accessible with a crane and fork lift truck.
- There is no hazard posed by system components.

 <b>WARNING</b>	When carrying out the following work, the robot must be moved several times between the individual work steps. While work is being carried out on the robot, it must always be secured by activating the EMERGENCY STOP device. Unintentional robot motions can cause injuries and damage to property. If work is carried out on an operational robot that is switched on, the robot must only be moved at reduced velocity. It must be possible to stop the robot at any time by activating an EMERGENCY STOP device. Operation must be limited to what is absolutely necessary. Warn all persons concerned before switching on and moving the robot.
--	--

**Procedure**

1. Secure the robot.
2. Remove tools and equipment.
3. Put the robot into operation and move it into the transport position (>>> Fig. 11-6 ).

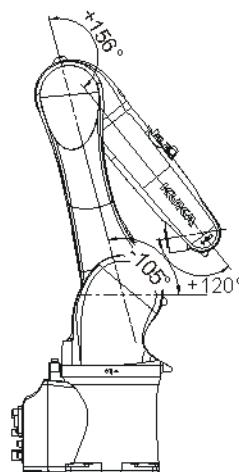

**Fig. 11-6: Transport position**

4. Secure the robot by activating the E-STOP device and then shut down the robot.
5. Release and unplug all peripheral connections.
6. Release and unplug the motor cable and data cable connectors.
7. Release and unplug the ground conductor.
8. Rotate the Load Lifting Attachment so that it can be screwed to the ceiling-mounted machine.
9. Lift the Load Lifting Attachment with a fork lift truck.  
The fork lift truck must remain in the fork slots of the Load Lifting Attachment during removal in order to prevent slipping.

**NOTICE**

When picking up the Load Lifting Attachment with the fork lift truck, the width of the fork slots (140 mm) must be taken into consideration. Damage to property may otherwise result.

10. Unscrew 2 M10x35 hexagon bolts (front hexagon bolts) and washers from the front of the base frame.
11. Carefully push the Load Lifting Attachment onto the base frame of the robot from the front (>>> Fig. 11-7).
12. Fasten the robot to the front of the Load Lifting Attachment with 2 M12x30 Allen screws (front Allen screws) and washers;  $M_A = 40 \text{ Nm}$ .

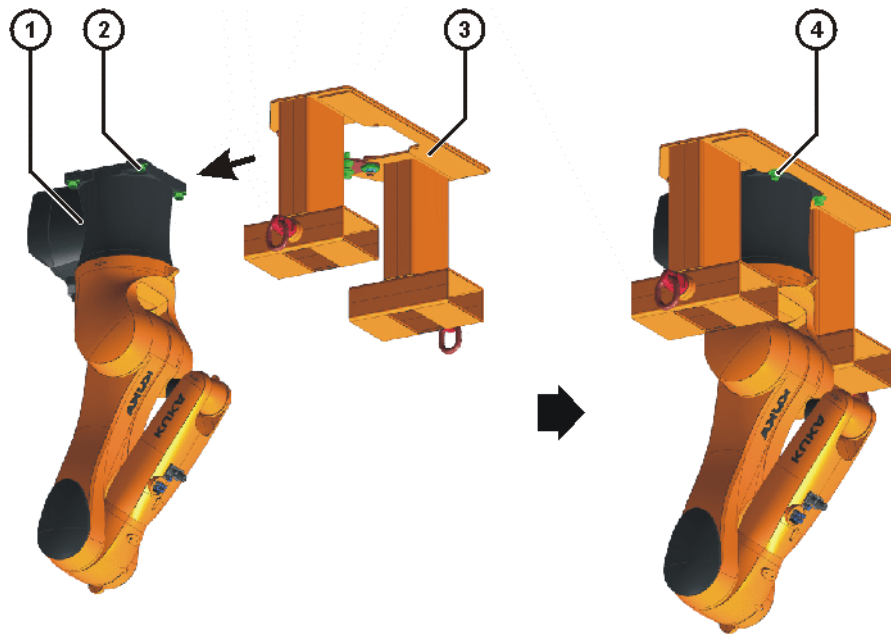

**Fig. 11-7: Fastening the Load Lifting Attachment to the robot**

- 1 Base frame
  - 2 M10x35 hexagon bolt (front)
  - 3 Load Lifting Attachment
  - 4 M12x30 Allen screw (front) and washer
13. Unscrew 2 M10x35 hexagon bolts (rear hexagon bolts) and washers from the rear of the base frame.
  14. Position swivel holders on base frame (>>> Fig. 11-8 ).
  15. Fasten the swivel holders to the rear of the base frame with 2 M12x30 Allen screws and washers;  $M_A = 40 \text{ Nm}$ .
  16. Lock the swivel holders on the Load Lifting Attachment with 2 M12x30 Allen screws.

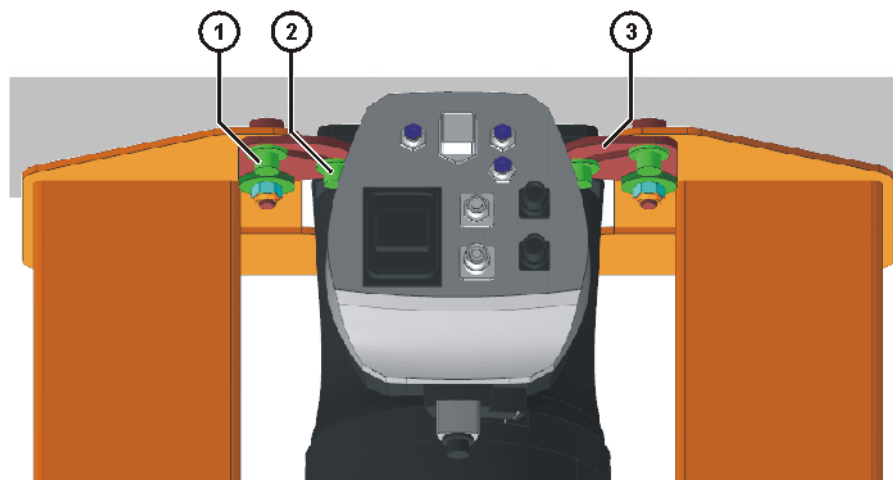

**Fig. 11-8: Positioning and fastening the swivel holders**

- 1 M12x30 Allen screw (locking screw)
  - 2 M12x30 Allen screw (rear)
  - 3 Swivel holder
17. Slowly lower the robot with a fork lift truck.

18. Attach lifting tackle to the 2 rotating swivel eyebolts on the Load Lifting Attachment and to the crane.
19. Move the fork lift truck slowly and carefully out of the fork slots of the Load Lifting Attachment.
20. Person 1:  
Slowly and carefully lift the robot with the crane.  
Person 2:  
Secure the robot against toppling during the lifting operation.

**WARNING**

Ensure that the robot does not topple during the lifting operation. Serious injuries and damage to property may otherwise result.

21. Slowly rotate the robot through 180° and carefully set it down.
22. Unscrew 4 M12x30 Allen screws (front and rear) and washers from the Load Lifting Attachment.
23. Unscrew 2 M12x30 Allen screws (locking screws) and washers from the swivel holders.
24. Rotate the swivel holders outwards.
25. Carefully push the Load Lifting Attachment down from the back of the base frame.
26. Prepare the robot for storage.

## 11.4 Storage

### Description

If the robot is to be put into long-term storage, the following points must be observed:

- The place of storage must be as dry and dust-free as possible.
- Avoid temperature fluctuations.
- Avoid wind and drafts.
- Avoid condensation.
- Use appropriate coverings that cannot detach themselves and which can withstand the expected environmental conditions.
- Do not leave any loose parts on the robot, especially ones that might knock against other parts.
- Do not leave the robot exposed to direct sunlight while in storage.
- Observe and comply with the permissible temperature ranges for storage.
- Select a storage location in which the packaging materials cannot be damaged.

### Procedure

1. Remove the robot.
2. Remove tools and equipment.
3. Clean and dry the robot. No dirt or cleaning agent residue may remain on or in the robot.
4. Perform a visual inspection of the robot.
5. Remove any foreign bodies.
6. Remove any corrosion.
7. Attach all covers to the robot and check that the seals are correctly in place.
8. Seal off electrical connections with suitable covers.
9. Seal hose connections by suitable means.
10. Cover the robot with plastic film and seal it at the base frame against dust. If necessary, add a desiccant beneath the sheeting.

## 11.5 Disposal

When the robot reaches the end of its useful life, it can be removed from the system and dismantled, and the materials can be disposed of properly by type.

The following table provides an overview of the materials used in the robot. All plastic components are marked with a material designation and must be disposed of accordingly.

Material, designation	Subassembly, component	Remark
Cast aluminum	Rotating column, arm, link arm, wrist, base frame	
Plastic	Panels, covers	
Steel	Gear units, screws and washers	
	Motors	Dispose of motors without dismantling them.
PUR	Cable sheaths	
Copper	Cables, wires	
PU	Hoses	
Cable grease	Cabling	See safety data sheet, consumables (>>> 12.2.2 "Safety data sheet for OBEEN FS 2 lubricant" Page 165)
Gear grease, oil	Gear units	See safety data sheet, consumables (>>> 12.2.1 "Safety data sheet for Flexolub®-A1 lubricant" Page 161)
NBR	Shaft seals, O-rings	





## 12 Appendix

### 12.1 Tightening torques

#### Tightening torques

The following tightening torques (Nm) are valid for screws and nuts where no other specifications are given.

The specified values apply to lightly oiled black (e.g. phosphated) and coated (e.g. mech.galv., zinc flake coatings) screws and nuts.

Screw thread	Strength class		
	8.8	10.9	12.9
M1.6	0.17 Nm	0.24 Nm	0.28 Nm
M2	0.35 Nm	0.48 Nm	0.56 Nm
M2.5	0.68 Nm	0.93 Nm	1.10 Nm
M3	1.2 Nm	1.6 Nm	2.0 Nm
M4	2.8 Nm	3.8 Nm	4.4 Nm
M5	5.6 Nm	7.5 Nm	9.0 Nm
M6	9.5 Nm	12.5 Nm	15.0 Nm
M8	23.0 Nm	31.0 Nm	36.0 Nm
M10	45.0 Nm	60.0 Nm	70.0 Nm
M12	78.0 Nm	104.0 Nm	125.0 Nm
M14	125.0 Nm	165.0 Nm	195.0 Nm
M16	195.0 Nm	250.0 Nm	305.0 Nm
M20	370.0 Nm	500.0 Nm	600.0 Nm
M24	640.0 Nm	860.0 Nm	1030.0 Nm
M30	1330.0 Nm	1700.0 Nm	2000.0 Nm

Screw thread	Strength class	
	8.8 ISO7991 Hexagon socket	10.9 ISO7380, ISO7381 Fillister head screw with hexa- gon socket
M3	0.8 Nm	0.8 Nm
M4	1.9 Nm	1.9 Nm
M5	3.8 Nm	3.8 Nm

Tighten M5 domed cap nuts with a torque of 4.2 Nm.

### 12.2 Safety data sheets

#### 12.2.1 Safety data sheet for Flexolub<sup>®</sup>-A1 lubricant

The following extract from the safety data sheet according to 1907/2006/EEC must be observed.

##### Section 1

##### Designation of substance/formulation and manufacturer

Name of substance/preparation	
Product name:	Flexolub <sup>®</sup> -A1
Use:	Gear lubricant for Harmonic Drive gear units

Manufacturer designation	
<b>Company:</b>	<b>Harmonic Drive AG</b>
<b>Address:</b>	Hoenbergstrasse 14, D-65555 Limburg a. d. Lahn
<b>Country:</b>	Germany
<b>Tel.:</b>	+49 (0)6431 5008-0
<b>Fax:</b>	+49 (0)6431 5008-119

## Section 2 Composition / Information about the components

<b>Chemical characterization:</b>	Combination of ester oils, lithium soap and additives.
-----------------------------------	--

## Section 3 Possible hazards

Hazard designation not applicable.

## Section 4 First aid measures

<b>Contact with eyes:</b>	Flush with plenty of water. If irritation continues, seek medical attention and present this safety data sheet.
<b>Skin contact:</b>	Remove contaminated clothing. Wash affected areas of skin with soap and water.  If grease has penetrated into the skin due to improper handling of a high-pressure lubrication gun, seek medical attention immediately and present this safety data sheet.
<b>Inhalation:</b>	Remove affected person to fresh air. If breathing stops, initiate artificial respiration. Seek medical assistance and present this safety data sheet.
<b>Ingestion:</b>	Do <b>not</b> induce vomiting. If the person is unconscious, do not give anything by mouth. Consult a physician immediately and present this safety data sheet.
<b>Notes to physician:</b>	Treatment should in general be symptomatic and directed at relieving any effects.  Note regarding high-pressure applications.  Injection into the skin due to contact with a product under high pressure constitutes a major medical emergency. Within a few hours the tissue swells up and becomes discolored and extremely painful, with severe subcutaneous necrosis.  Surgical treatment is absolutely imperative. Comprehensive opening of the wound and the tissue beneath it is necessary in order to reduce tissue loss and to prevent or limit lasting damage. The high pressure can cause the product to penetrate extensive areas of tissue layers.

## Section 5 Fire-fighting measures

<b>Suitable extinguishing agents:</b>	In the event of a fire, use a dry-chemical extinguisher with ABC or BC powder, or a foam or carbon dioxide extinguisher.
<b>Unsuitable extinguishing agents:</b>	Do <b>not</b> use water.
<b>Protection of fire-fighters:</b>	In the case of fire, hazardous gases may develop. Respiratory protection is necessary during fire-fighting measures.

## Section 6 Measures after unintended release

<b>Environmental precautions and clean-up methods:</b>	Wipe up small amounts with a cleaning cloth or absorb with oil-binding agents and dispose of in accordance with (>>> "Section 13" Page 164). Contain large amounts of spilled product with sand or other inert material. Prevent from entering sewers, streams and waterways. Safeguard entrances to the drainage system. Slip hazard! Avoid fire and naked lights. No smoking!
--	---

## Section 7 Handling and storage

<b>Handling:</b>	Store in a dry place at room temperature in tightly sealed containers. When using the product, avoid the formation of oil mist if at all possible.
<b>Storage:</b>	The product can be kept for at least 5 years in the original, unopened containers under the specified storage conditions.  If the lubricant is to be used at higher temperatures, suitable fume extraction or adequate ventilation must be provided in the place of work.  The standard safety precautions used in the mineral oil industry are to be observed.

## Section 8 Exposure limits and personal protective equipment

Protective measures	
<b>Hygiene measures:</b>	Keep away from food, drink and tobacco products. Wash hands before breaks and at the end of work. Store work clothes separately. Change contaminated clothing. The usual precautions when handling chemicals must be observed.
<b>Respiratory protection:</b>	Not necessary if used correctly for the intended purpose. Avoid breathing in vapors (oil mist).
<b>Hand protection:</b>	In the case of prolonged or repeated skin contact, wear protective gloves (e.g. made of latex, wearing time > 30 min.; butyl rubber, wearing time > 8 hours).
<b>Eye protection:</b>	Not necessary if used correctly for the intended purpose.

## Section 9 Physical and chemical properties

General information	
<b>Physical state:</b>	Fluid
<b>Color:</b>	Magenta
<b>Odor:</b>	Weak

Important information on health and environmental protection and on safety	
<b>Boiling point:</b>	>250 °C
<b>Density:</b>	0.95 g/cm <sup>3</sup> at 20 °C
<b>Vapor pressure:</b>	< 0.1 mbar at 20 °C 0.12 mbar at 55 °C
<b>Viscosity of base oil:</b>	25 mm <sup>2</sup> /s at 40 °C; DIN EN ISO 3104 5.2 mm <sup>2</sup> /s at 100 °C
<b>Drop point:</b>	> 200 °C; DIN ISO 2176
<b>Solubility:</b>	Insoluble in water
<b>pH value:</b>	Not determined
<b>Flash point:</b>	> 200 °C; DIN ISO 2592

Important information on health and environmental protection and on safety	
Ignition temperature:	>300 °C
Explosion limit:	Not known

#### Section 10 Stability and reactivity

Thermal decomposition:	>220 °C
Hazardous decomposition products:	None known if handled and stored correctly. In the case of improper use above the decomposition temperature, or in the event of a fire, harmful vapors may arise (carbon monoxide).
Hazardous reactions:	With strong oxidants (e.g. liquid or compressed oxygen), very strong acids, very strong alkalis.

#### Section 11 Toxicological information

Oral toxicity: (analogy observation)	LD <sub>50</sub> > 2,000 mg/kg (rat).
Epidermal toxicity: (analogy observation)	One ingredient of the grease may cause weak skin irritation in the case of frequent or excessive contact.

No health problems expected if used for the intended purpose.

#### Section 12 Ecological information

Water hazard classification 1 (WGK):	Minor water hazard (classification acc. to German Administrative Regulation on the Classification of Substances Hazardous to Water into Water Hazard Classes (VwVwS), dated May 1999).  Prevent from entering the soil, surface waters, groundwater or the drainage system.
--------------------------------------	---

#### Section 13 Disposal information

The product must be disposed of in an authorized incineration plant in accordance with the applicable regulations on hazardous waste.

Contains no halogen compounds or heavy metals.

LAGA waste code:	542 02: for waste grease. 542 09: for solid materials contaminated with grease or oil.
EWC waste code:	12 01 12: for used waxes and greases. 15 02 99 D1: for used absorbent and filter materials, cleaning rags and protective clothing with harmful contaminants. 17 02 99 D1: for used wood, glass and plastics with harmful contaminants (e.g. lubricant residues in plastic tubes).

#### Section 14 Transport information

ADR/RID	Not hazardous	
Hazard number (Kemler code):	-	Substance code (UN no.): -
Packaging group:	-	Hazard label: -
Class:	-	

GGVSee/IMDG code	Not hazardous	
IMDG code:	-	UN no.: -

<b>Class:</b>	-	Packaging group: -
<b>Label:</b>	-	

<b>ICAO/IATA</b>	Not hazardous	
<b>ICAO/IATA class:</b>	-	UN/ID no.: -
<b>Packing list:</b>	-	

## Section 15 Regulations

No labeling required according to the German Dangerous Substances Order and corresponding EC directives.

The product does not contain any volatile organic compounds listed in the Swiss VOC List, Appendix I (dated 12 November 1997) or VOC (TRGS 220; 31. BlmSCH).

Not classified in the German Ordinance on Industrial Safety and Health (Be-trSichV / formerly VbF class).

<b>Fire classification:</b>	
<b>Water hazard classification (WGK):</b>	1

## Section 16 Other information

### Notes for the reader

The information given here is based on the current state of our knowledge and experience. The safety data sheet describes products with regard to safety requirements. The information given does not represent a warranty of characteristics. All data refer to the product in the delivery condition.

This safety data sheet supersedes all previous versions for this product.

### 12.2.2 Safety data sheet for OBEEN FS 2 lubricant

The following extract from the safety data sheet according to 91/155/EEC must be observed.

## Section 1 Identification of the substance or mixture and of the company

### ■ 1.1 Product identifier

<b>Product name:</b>	<b>Obeen FS 2</b>
<b>Product code:</b>	461585-DE03
<b>SDS no.:</b>	461585
<b>Product type:</b>	Paste

### ■ 1.2 Relevant identified uses of the substance or mixture and uses advised against

<b>Use of substance or mixture:</b>	Lubricant for food machinery For specific instructions for use, see the corresponding technical data sheet or contact a company representative.
-------------------------------------	--

### ■ 1.3 Details of the supplier of the safety data sheet

Manufacturer designation	
<b>Supplier:</b>	<b>BP Europa SE - Geschäftsbereich Industrieschmierstoffe</b> Erkelenzer Strasse 20 D-41179 Mönchengladbach Germany
<b>Phone:</b>	+49 (0) 2161 909 30
<b>Fax:</b>	+49 (0) 2161 909 392
<b>e-mail address:</b>	MSDSadvice@bp.com

- 1.4 Emergency telephone number

<b>Emergency hotline</b>	Carechem: +44 (0)1235 239,670 (available 24 hours a day)
--------------------------	--

## Section 2 Possible hazards

- 2.1 Classification of the substance or mixture

<b>Product definition:</b>	Mixture
<b>Classification acc. to Directive 1999/45/EC [Dangerous Preparation Directive]:</b>	The product is classified as hazardous according to Directive 1999/45/EC and its annexes.
<b>Rating:</b>	R52/53
<b>Dangers to the environment:</b>	Harmful to aquatic organisms, may cause long-term adverse effects in the aquatic environment.

Refer to the section "Other information" (>>> "Section 16" Page 179) for the full text of the above R-phrases and H-phrases.

The sections "Toxicological information" (>>> "Section 11" Page 175) and "Ecological information" (>>> "Section 12" Page 176) contain more detailed information on health hazards, symptoms and environmental risks.

- 2.2 Label elements

<b>Risk (R) phrases:</b>	R52/53: Harmful to aquatic organisms, may cause long-term adverse effects in the aquatic environment.
<b>Safety (S) phrases:</b>	S61: Avoid release to the environment. Refer to special instructions/safety data sheet.
<b>Supplemental label elements:</b>	Not applicable

Special packaging requirements	
<b>Containers to be fitted with child-resistant fastenings:</b>	Not applicable
<b>Tactile warning of danger:</b>	Not applicable

- 2.3 Other hazards

<b>Other hazards which do not result in classification:</b>	Defatting to the skin Note regarding high-pressure applications Injection into the skin due to contact with a product under high pressure constitutes a major medical emergency. See "Notes to physician" in this safety data sheet (>>> "Section 4" Page 168).
---	---

## Section 3 Composition / Information about the components

<b>Substance/preparation:</b>	Mixture Synthetic lubricant and additives. Thickeners.
-------------------------------	---

Classification					
Product/ ingredient name	Identifiers	%	67/548/EEC	Regulation (EC) No. 1272/2008 [CLP]	Type
Amines, C11-14 branched alkyl, mono-hexyl and dihexyl phosphates	EC: 279-632-6 CAS: 80939-62-4	> = 0.25 - < 1	Xi; R36/38 N; R51/53	Skin Irrit. 2, H315  Eye Irrit. 2, H319  Aquatic Chronic 2, H411	[1]
1H-Imidazol-1-ethanol, 2-(8-heptadecenyl)-4,5-dihydro	EC: 202-414-9 CAS: 95-38-5	> = 0.25 - < 1	Xn; R22, R48/22  C; R34  N; R50/53	Acute Tox. 4, H302  Skin Corr. 1A, H314  Eye Dam. 1, H318  STOT RE 2, H373 (oral)  Aquatic Acute 1, H400  Aquatic Chronic 1, H410	[1]
(Z)-N-methyl-N-(1-oxo-9-octadecenyl)glycin	REACH #: 01-2119488991-20  EC: 203-749-3  CAS: 110-25-8	> = 0.1 - < 1	Xn; R20  Xi; R41, R38  N; R50	Acute Tox. 4, H332  Skin Irrit. 2, H315  Eye Dam. 1, H318  Aquatic Acute 1, H400	[1]

Refer to the section "Other information" (>>> "Section 16" Page 179) for the full text of the above R-phrases.

Type

[1] Substance classified as hazardous to health or hazardous to the environment

[2] Substance with an occupational exposure limit

[3] Substance meets the criteria for PBT according to Regulation (EC) No. 1907/2006, Annex XIII

[4] Substance meets the criteria for vPvB according to Regulation (EC) No. 1907/2006, Annex XIII

[5] Substance of equivalent concern

The occupational exposure limit values, where available, are specified in the section "Limitation and monitoring of exposure / Personal protective equipment" (>>> "Section 8" Page 171).

## Section 4

### First aid measures

#### ■ 4.1 Description of first aid measures

<b>Contact with eyes:</b>	In case of contact, rinse eyes immediately with plenty of water for at least 15 minutes. Eyelids should be held away from the eyeball to ensure thorough rinsing. Check for and remove any contact lenses. Get medical attention.
<b>Skin contact:</b>	Wash skin with soap and water, or use an approved skin cleansing agent. Take off clothing and shoes if they become contaminated with product. Wash clothing before reuse. Clean shoes thoroughly before reuse. If irritation occurs consult a doctor.
<b>Inhalation:</b>	Take affected person into fresh air. Consult a doctor if symptoms persist.
<b>Ingestion:</b>	Do not induce vomiting unless explicitly directed to do so by medical personnel. Never give anything by mouth to an unconscious person. If the person is unconscious, place into the recovery position and consult a doctor immediately. Seek medical attention if symptoms occur.
<b>Protection of first-aiders:</b>	No measures should be taken that involve a risk to personnel or have not been adequately trained. It may be dangerous for the person providing first aid to administer mouth-to-mouth resuscitation.

- 4.2 Most important symptoms and effects, either acute or delayed  
See Section "Toxicological information" (>>> "Section 11" Page 175) for more detailed information on health effects and symptoms.
- 4.3 Indication of any immediate medical attention and special treatment needed

<b>Notes to physician:</b>	<p>Treatment should in general be symptomatic and directed at relieving any effects.</p> <p>Note regarding high-pressure applications</p> <p>Injection into the skin due to contact with a product under high pressure constitutes a major medical emergency. The injuries appear minor at first, but within a few hours the tissue swells up and becomes discolored and extremely painful, with severe subcutaneous necrosis.</p> <p>Surgical treatment is absolutely imperative. Comprehensive opening of the wound and the tissue beneath it is necessary in order to reduce tissue loss and to prevent or limit lasting damage.</p> <p>The high pressure can cause the product to penetrate extensive areas of tissue layers.</p>
----------------------------	---

## Section 5

### Fire-fighting measures

#### ■ 5.1 Extinguishing agents



<b>Suitable extinguishing agents:</b>	In the event of a fire, use water spray (mist), alcohol resistant foam, dry chemical or carbon dioxide-based extinguisher or spray
<b>Unsuitable extinguishing agents:</b>	Do not use a waterjet.

- 5.2 Special hazards arising from the substance or mixture

<b>Hazards from the substance or mixture:</b>	In a fire or if heated, a pressure increase will occur and the container may burst.
<b>Hazardous combustion products:</b>	The combustion products may include the following compounds: Carbon oxides (CO, CO <sub>2</sub> ) Metal oxides/oxides

- 5.3 Advice for fire-fighters

<b>Special precautions for fire-fighters:</b>	Extinguishing water contaminated with this product must be contained and prevented from entering surface waters or the sewage or drainage system. No measures should be taken that involve a risk to personnel or have not been adequately trained. Promptly isolate the scene by removing all persons from the vicinity of the incident if there is a fire. This substance is harmful to aquatic organisms.
<b>Special protective equipment for fire-fighting:</b>	Fire-fighters should wear appropriate protective equipment and self-contained breathing apparatus (SCBA) with a full face-piece operated in positive pressure mode. Clothing for fire-fighters (including helmets, protective boots and gloves) conforming to European standard EN 469 will provide a basic level of protection for chemical incidents.

## Section 6 Measures after unintended release

- 6.1 Personal precautions, protective equipment and emergency procedures

<b>For non-emergency personnel:</b>	Contact emergency personnel. No measures should be taken that involve a risk to personnel or have not been adequately trained. Evacuate the environment. Refuse access to personnel who are not required or are unprotected. Do not touch or step on any spilled substance. Floors may be slippery; use care to avoid falling. Vapor or mist must not be inhaled. Ensure good ventilation. Put on appropriate personal protective equipment.
<b>For emergency responders:</b>	Entry into a confined space or poorly ventilated area contaminated with vapor, mist or fumes is extremely hazardous without the correct respiratory protective equipment and a safe system of work. Wear self-contained breathing apparatus. Wear a suitable chemical protective suit. Chemical-resistant boots.  See also the information for non-emergency personnel under "Personal safety precautions".

- 6.2 Environmental protection measures

Prevent released material from dispersing or flowing away and from coming into contact with soil, surface waters and drainage system. Notify the relevant authorities if the product has caused pollution (sewers, surface waters, ground or air). Substance is a water pollutant.

- 6.3 Methods and material for containment and cleaning up

<b>Small spills:</b>	Stop the leak if you can do so without risk. Remove container from spill area. Disposal should be entrusted to a recognized waste disposal company. Remove solid or absorbed material using a tool and place in a suitable, labeled waste container.
<b>Large spills:</b>	<p>Contact emergency personnel immediately. Stop the leak if you can do so without risk. Remove container from spill area. Approach the release from upwind.</p> <p>Prevent entry into drainage system, surface waters, basements or confined areas. Contain spilled material using a non-combustible absorbent (e.g. sand, soil, vermiculite, diatomaceous earth) and place it in a container provided for the purpose of disposal in accordance with the local regulations. Contaminated absorbents can be just as dangerous as the released material. If no emergency personnel are available, contain spilled material. Remove spilled material with a vacuum cleaner or a shovel and deposit it in suitable disposal or recycling containers. Cover the surface contaminated by the spilled product with an oil absorption agent. Disposal should be entrusted to a recognized waste disposal company.</p>

■ 6.4 Reference to other sections

See Section "Identification of the substance or mixture and of the company" (>>> "Section 1" Page 165) for emergency contact information.

See Section "Fire-fighting measures" (>>> "Section 5" Page 168) for fire-fighting measures.

See Section "Limitation and monitoring of exposure / Personal protective equipment" (>>> "Section 8" Page 171) for information on appropriate personal protective equipment.

See Section "Ecological information" (>>> "Section 12" Page 176) for environmental precautions.

See Section "Disposal information" (>>> "Section 13" Page 177) for additional waste treatment information.

**Section 7**

**Handling and storage**

■ 7.1 Precautions for safe handling

<b>Safety measures:</b>	<p>Put on appropriate personal protective equipment. Do not ingest. Avoid contact with eyes, skin and clothing. Avoid breathing in any vapors or mist. Keep in the original container or an approved alternative made from a compatible material, kept tightly closed when not in use. Do not reuse container.</p> <p>Empty containers contain product residues and can be dangerous.</p>
<b>Advice on general occupational hygiene:</b>	<p>Eating, drinking and smoking should be prohibited in areas where this material is handled, stored and processed. Wash thoroughly after handling. Remove contaminated clothing and protective equipment before entering eating areas.</p> <p>See Section "Limitation and monitoring of exposure / Personal protective equipment" (&gt;&gt;&gt; "Section 8" Page 171) for additional information on hygiene measures.</p>

■ 7.2 Conditions for safe storage, including any incompatibilities

Store and use only in equipment/containers designed for use with this product. Keep away from heat and direct sunlight. Keep containers tightly closed and sealed until usage. Containers that have been opened must be carefully resealed and kept upright to prevent leakage. Do not store in unlabeled containers. Store in accordance with local regulations. Store in a

dry, cool and well-ventilated area, away from incompatible materials (see Section "Stability and reactivity" (>>> "Section 10" Page 175)).

Germany - storage class: 11

- 7.3 Specific end use(s)

Recommendations: See Section 1.2 and Exposure scenarios in annex, if applicable.

## Section 8 Limitation and monitoring of exposure / Personal protective equipment

- 8.1 Control parameters

<b>Occupational exposure limits:</b>	No exposure limit value known.
--------------------------------------	--------------------------------

<b>Recommended monitoring procedures:</b>	If this product contains ingredients with exposure limits, personal, workplace atmosphere or biological monitoring may be required to determine the effectiveness of the ventilation or other control measures and/or the necessity of using respiratory protective equipment. Reference should be made to monitoring standards, such as the following: European Standard EN 689 (Workplace atmospheres - Guidance for the assessment of exposure by inhalation to chemical agents for comparison with limit values and measurement strategy), European Standard EN 14042 (Workplace atmospheres - Guide for the application and use of procedures for the assessment of exposure to chemical and biological agents), European Standard EN 482 (Workplace atmospheres - General requirements for the performance of procedures for the measurement of chemical agents). Reference to national guidance documents for methods for the determination of hazardous substances will also be required.
---	---

<b>Derived No Effect Level:</b>	No DNELs/DMELs available.
---------------------------------	---------------------------

<b>Predicted No Effect Concentration:</b>	No PNECs available.
---	---------------------

- 8.2 Limitation and monitoring of exposure

<b>Appropriate engineering controls:</b>	<p>Provide extractor ventilation or other engineering controls to keep the concentrations of vapors below their respective occupational exposure limits.</p> <p>All activities involving chemicals should be assessed for their risks to health, to ensure exposures are adequately controlled. Personal protective equipment should only be considered after other forms of control measures (e.g. engineering controls) have been suitably evaluated. Personal protective equipment should conform to the applicable standards and be suitable for the intended purpose, be kept in good condition and be maintained in accordance with the regulations. Select personal protective equipment in compliance with the valid standards. For this purpose, please consult your supplier of personal protective equipment. Further information about standards is available from your national organization responsible.</p> <p>The final choice of protective equipment will depend on a risk assessment. It must always be ensured that all items of personal protective equipment are compatible with one another.</p>
--	---

<b>Personal safety precautions</b>	
<b>Hygiene measures:</b>	Wash hands, forearms and face thoroughly after handling chemical products and before eating, smoking or using the toilet, as well as at the end of the working day. Ensure that eye-wash stations and safety showers are close to the workstation location.
<b>Respiratory protection:</b>	<p>Respiratory protection is not normally required where there is adequate natural or local exhaust ventilation to control exposure.</p> <p>Where there is insufficient ventilation, wear suitable respiratory equipment.</p> <p>The correct choice of respiratory protection depends upon the chemicals being handled, the conditions of work and use, and the condition of the respiratory equipment. Safety procedures should be developed for each intended application. Respiratory protection equipment should always be chosen in consultation with the manufacturer and in accordance with the local working conditions.</p>
<b>Eye/face protection:</b>	Protective goggles with side shields.

<b>Skin protection</b>	
<b>General information:</b>	<p>Because specific work environments and material handling practices vary, safety procedures should be developed for each intended application. The correct choice of protective gloves depends upon the chemicals being handled, and the conditions of work and use. Most gloves provide protection for only a limited time before they must be discarded and replaced (even the best chemically resistant gloves will break down after repeated chemical exposures).</p> <p>Protective gloves should therefore be selected in consultation with the supplier/manufacturer, giving full consideration to the specific working conditions.</p> <p>Recommended: nitrile gloves.</p>
<b>Breakthrough time:</b>	<p>Breakthrough time data are generated by glove manufacturers under laboratory test conditions and represent how long a glove can be expected to provide effective permeation resistance. It is important when following breakthrough time recommendations that actual workplace conditions are taken into account. Always consult with your glove supplier for up-to-date technical information on breakthrough times for the recommended glove type.</p> <p>Our recommendations on the selection of gloves are as follows:</p> <p>Continuous contact:</p> <p>Gloves with a minimum breakthrough time of 240 minutes, or &gt;480 minutes if suitable gloves can be obtained.</p> <p>If suitable gloves are not available to offer that level of protection, gloves with shorter breakthrough times may be acceptable as long as appropriate glove maintenance and replacement regimes are determined and adhered to.</p> <p>Short-term / splash protection:</p> <p>Recommended breakthrough times as above.</p> <p>It is recognized that for short-term, transient exposures, gloves with shorter breakthrough times may commonly be used. Therefore, appropriate maintenance and replacement regimes must be determined and rigorously followed.</p>

<b>Skin protection</b>	
<b>Glove thickness:</b>	<p>For general applications, we recommend gloves with a thickness typically greater than 0.35 mm.</p> <p>It should be emphasized that glove thickness is not necessarily a good predictor of glove resistance to a specific chemical, as the permeation efficiency of the glove will be dependent on the exact composition of the glove material. Therefore, glove selection should also be based on consideration of the task requirements and knowledge of breakthrough times.</p> <p>Glove thickness may also vary depending on the glove manufacturer, the glove type and the glove model. Therefore, the manufacturer's technical data should always be taken into account to ensure selection of the most appropriate glove for the task.</p> <p>Note: Depending on the activity being conducted, gloves of varying thickness may be required for specific tasks. For example:</p> <ul style="list-style-type: none"> <li>■ Thinner gloves (down to 0.1 mm or less) may be required where a high degree of manual dexterity is needed. However, these gloves are only likely to give short duration protection and would normally be just for single use applications, then disposed of.</li> <li>■ Thicker gloves (up to 3 mm or more) may be required where there is a mechanical (as well as a chemical) risk, i.e. where there is abrasion or puncture potential.</li> </ul>
<b>Skin and body:</b>	<p>Use of protective clothing is good industrial practice.</p> <p>Personal protective equipment for the body should be selected on the basis of the task being performed and the risks involved and should be approved by a specialist before handling this product.</p> <p>Cotton or polyester/cotton overalls only provide protection against light, superficial contamination which will not soak through to the skin. Overalls should be laundered on a regular basis. When the risk of skin exposure is high (e.g. when cleaning up spillages or if there is a risk of splashing), then chemical-resistant aprons and/or impervious chemical suits and boots will be required.</p>
<b>Environmental exposure controls:</b>	<p>Emissions from ventilation or work process equipment should be checked to ensure they comply with the requirements of environmental protection legislation. In some cases, fume scrubbers, filters or engineering modifications to the process equipment will be necessary to reduce emissions to acceptable levels.</p>

## Section 9

### Physical and chemical properties

#### ■ 9.1 Information on basic physical and chemical properties

<b>Appearance:</b>	Paste
<b>Physical state</b>	
<b>Appearance:</b>	Amber
<b>Color</b>	
<b>Odor:</b>	Mild
<b>Odor threshold:</b>	Not available
<b>pH value:</b>	Not available

<b>Melting point/freezing point:</b>	Not available
<b>Initial boiling point and boiling range:</b>	Not available
<b>Drop point:</b>	>230 °C
<b>Flash point:</b>	Closed cup: > 150 °C (> 302 °F) [Estimated. Base oils.]
<b>Evaporation rate:</b>	Not available
<b>Flammability (solid, gas):</b>	Not available
<b>Upper / lower flammability or explosion limits:</b>	Not available
<b>Vapor pressure:</b>	Not available
<b>Vapor density:</b>	Not available
<b>Relative density:</b>	Not available
<b>Density:</b>	<1000 kg/m <sup>3</sup> (<1 g/cm <sup>3</sup> ) at 20 °C
<b>Solubility:</b>	Insoluble in water
<b>Partition coefficient (n-octanol/water):</b>	Not available
<b>Auto-ignition temperature:</b>	Not available
<b>Decomposition temperature:</b>	Not available
<b>Viscosity:</b>	Not available
<b>Explosive properties:</b>	Not available
<b>Oxidizing properties:</b>	Not available

- 9.2 Other information  
No additional information.

## Section 10

### Stability and reactivity

- 10.1 Reactivity  
No specific test data available for this product. Refer to “Conditions to be avoided” and “Incompatible materials” for additional information.
- 10.2 Chemical stability  
The product is stable.
- 10.3 Possibility of hazardous reactions  
No hazardous polymerization occurs under normal storage conditions and in normal use.  
No hazardous reactions occur under normal storage conditions and in normal use.
- 10.4 Conditions to be avoided  
No specific data.
- 10.5 Incompatible materials  
Reactive or incompatible with the following substances: oxidizing materials.
- 10.6 Hazardous decomposition products  
No hazardous decomposition products should be formed under normal conditions of storage and use.

## Section 11

### Toxicological information

- 11.1 Information on toxicological effects

<b>Information on the likely routes of exposure:</b>	Routes of entry anticipated: dermal, inhalation.
--	--

Potential acute health effects	
<b>Inhalation:</b>	Vapor inhalation under ambient conditions is not normally a problem due to low vapor pressure.
<b>Ingestion:</b>	No particular effects or risks known.
<b>Skin contact:</b>	May cause skin dryness and irritation.
<b>Contact with eyes:</b>	No particular effects or risks known.

Symptoms related to the physical, chemical and toxicological characteristics	
<b>Inhalation:</b>	No specific data.
<b>Ingestion:</b>	No specific data.
<b>Skin contact:</b>	Adverse symptoms may include the following: Irritation Dryness Cracking
<b>Contact with eyes:</b>	No specific data.

Delayed and immediate effects and also chronic effects from short-term and long-term exposure	
<b>Inhalation:</b>	Inhalation of oil mist or vapors at elevated temperatures may cause respiratory irritation.
<b>Ingestion:</b>	Ingestion of large quantities may cause nausea and diarrhea.
<b>Skin contact:</b>	Prolonged or repeated contact can dry out the skin and lead to irritation and/or dermatitis.
<b>Contact with eyes:</b>	Potential risk of transient stinging or redness if accidental eye contact occurs.

Potential chronic health effects	
<b>General:</b>	Prolonged or repeated contact can make the skin dry and lead to irritation, chapping and/or dermatitis.
<b>Carcinogenicity:</b>	No particular effects or risks known.
<b>Mutagenicity:</b>	No particular effects or risks known.
<b>Developmental effects:</b>	No particular effects or risks known.
<b>Fertility effects:</b>	No particular effects or risks known.

## Section 12

### Ecological information

- 12.1 Toxicity  
Harmful to aquatic organisms, may cause long-term adverse effects in the aquatic environment.
- 12.2 Persistence and degradability  
Not expected to be rapidly degradable.
- 12.3 Bioaccumulative potential  
Not available
- 12.4 Mobility in soil  
Soil/water partition coefficient ( $K_{OC}$ ): Not available  
Mobility: Non-volatile. Grease. Insoluble in water.
- 12.5 Results of PBT and vPvB assessment  
PBT: Not applicable  
vPvB: Not applicable
- 12.6 Other adverse effects  
No particular effects or risks known.



## Section 13

## Disposal information

- 13.1 Waste treatment methods

<b>Product</b>	
<b>Waste disposal methods:</b>	Generation of waste should be avoided or minimized if at all possible. Significant quantities of waste product residues should not be disposed of via the foul sewer but processed in a suitable effluent treatment plant. Disposal of surplus material and products not suitable for recycling must be entrusted to a recognized waste disposal company. Disposal of this product and of its solutions and by-products must at all times comply with the environmental protection requirements, waste disposal legislation and the requirements of local authorities.
<b>Hazardous waste:</b>	Yes

<b>European Waste Catalog (EWC)</b>	
<b>Waste code:</b>	12 01 12*
<b>Waste designation:</b>	Used waxes and greases.

Use of the product for purposes other than those specified and/or impurities can necessitate the use of a different waste code number for the waste producer.

<b>Packaging</b>	
<b>Waste disposal methods:</b>	Disposal must be carried out by an authorized waste disposal contractor. Recycle if possible.
<b>Waste code:</b>	15 01 10*
<b>European Waste Catalog (EWC)</b>	Packaging containing the residue of hazardous materials or contaminated by hazardous materials.
<b>Special precautionary measures:</b>	Waste and containers must be disposed of in a safe manner. Care should be taken when handling emptied containers that have not been cleaned or rinsed out. Empty containers and linings may contain product residues. Empty containers represent a fire hazard as they may contain flammable product residues and vapor. Never weld, solder or braze empty containers. Prevent released material from dispersing or flowing away and from coming into contact with soil, surface waters and drainage system.

## Section 14

## Transport information

- ADR/RID
  - 14.1 UN number  
Not regulated
  - 14.2 UN proper shipping name  
-
  - 14.3 Transport hazard class(es)  
-
  - 14.4 Packing group  
-
  - 14.5 Environmental hazards  
No  
Further information  
-
- ADN
  - 14.1 UN number

- Not regulated
- 14.2 UN proper shipping name  
-
- 14.3 Transport hazard class(es)  
-
- 14.4 Packing group  
-
- 14.5 Environmental hazards  
No
- Further information  
-
- IMDG
  - 14.1 UN number:  
Not regulated
  - 14.2 UN proper shipping name  
-
  - 14.3 Transport hazard class(es)  
-
  - 14.4 Packing group  
-
  - 14.5 Environmental hazards  
No
  - Further information  
-
- IATA
  - 14.1 UN number  
Not regulated
  - 14.2 UN proper shipping name  
-
  - 14.3 Transport hazard class(es)  
-
  - 14.4 Packing group  
-
  - 14.5 Environmental hazards  
No
  - Further information  
-
- 14.6 Special precautions for user  
Not available

## Section 15

### Regulatory information

- 15.1 Safety, health and environmental regulations/legislation specific for the substance or mixture

<b>EC regulation (EC) No. 1907/2006 (REACH):</b> <b>Annex XIV - List of substances subject to authorization:</b> <b>Substances of very high concern:</b>	None of the components are listed.
<b>Annex XVII - Restrictions on the manufacture, placing on the market and use of certain dangerous substances, mixtures and articles:</b>	Not applicable

<b>Miscellaneous provisions</b>	
<b>REACH Status:</b>	The company, as identified in Section "Identification of the substance or mixture and of the company" (>>> "Section 1" Page 165), sells this product in the EU in compliance with the current requirements of REACH.
<b>US inventory (TSCA 8b):</b>	All components are listed or exempted.
<b>Australian inventory (AICS):</b>	All components are listed or exempted.
<b>Canadian inventory:</b>	At least one component is not listed.
<b>Inventory of Existing Chemical Substances in China (IECSC):</b>	All components are listed or exempted.
<b>Japanese inventory of Existing and New Chemical Substances (ENCS):</b>	All components are listed or exempted.
<b>Korean Existing Chemicals Inventory (KECI):</b>	All components are listed or exempted.
<b>Philippine Inventory of Chemicals and Chemical Substances (PICCS):</b>	Not determined.

<b>National regulations</b>	
<b>Water hazard classification:</b>	2, Annex no. 4 (classification acc. to the German Administrative Regulation on the Classification of Substances Hazardous to Waters into Water Hazard Classes (VwVwS))

- 15.2 Chemical safety assessment  
This product contains substances for which Chemical Safety Assessments are still required.

## Section 16

### Other information

#### Abbreviations and acronyms:

ADN: European Provisions concerning the International Carriage of Dangerous Goods by Inland Waterway

ADR: The European Agreement Concerning the International Carriage of Dangerous Goods by Road

ATE: Acute Toxicity Estimate

BCF: Bioconcentration Factor

CAS: Chemical Abstracts Service

CLP: Classification, Labelling and Packaging Regulation [Regulation (EC) no. 1272/2008]

CSA: Chemical Safety Assessment

CSR: Chemical Safety Report

DMEL: Derived Minimal Effect Level

DNEL: Derived No Effect Level

DPD: Dangerous Preparations Directive [1999/45/EC]

DSD: Dangerous Substances Directive [67/548/EEC]

EINECS: European Inventory of Existing Commercial Chemical Substances

ES: Exposure Scenario

EUH statement: CLP-specific hazard statement

EWC: European Waste Catalog

GHS: Globally Harmonized System of Classification and Labelling of Chemicals

IATA: International Air Transport Association

IBC: Intermediate Bulk Container

IMDG: International Maritime Dangerous Goods

LogPow: Decadic logarithm of the octanol/water partition coefficient

MARPOL 73/78: International Convention for the Prevention of Pollution From Ships, 1973 as modified by the Protocol of 1978. ("Marpol" = marine pollution)

OECD: Organisation for Economic Co-operation and Development

PBT: Persistent, Bioaccumulative and Toxic

PNEC: Predicted No Effect Concentration

RID: The Regulations concerning the International Carriage of Dangerous Goods by Rail

RRN: REACH Registration Number

SADT: Self-Accelerating Decomposition Temperature

SVHC: Substances of Very High Concern

STOT-RE: Specific Target Organ Toxicity - Repeated Exposure

STOT-SE: Specific Target Organ Toxicity - Single Exposure

TWA: Time-Weighted Average

UN: United Nations

UVCB: Complex hydrocarbon substance

VOC: Volatile Organic Compounds

vPvB: Very Persistent and Very Bioaccumulative

<b>Full text of abbreviated H-phrases:</b>	<p>H302: Harmful if swallowed.</p> <p>H314: Causes severe skin burns and eye damage.</p> <p>H315: Causes skin irritation.</p> <p>H318: Causes serious eye damage.</p> <p>H319: Causes serious eye irritation.</p> <p>H332: Harmful if inhaled.</p> <p>H373: May cause damage to organs through prolonged or repeated exposure if swallowed.</p> <p>H400: Very toxic to aquatic organisms.</p> <p>H410: Very toxic to aquatic organisms with long-lasting effects.</p> <p>H411: Toxic to aquatic organisms with long-lasting effects.</p>
<b>Full text of classifications [CLP/GHS]:</b>	<p>Acute Tox. 4, H302: ACUTE TOXICITY (oral) - Category 4</p> <p>Acute Tox. 4, H332: ACUTE TOXICITY (inhalation) - Category 4</p> <p>Aquatic Acute 1, H400: ACUTE AQUATIC HAZARD - Category 1</p> <p>Aquatic Chronic 1, H410: LONG-TERM AQUATIC HAZARD - Category 1</p> <p>Aquatic Chronic 2, H411: LONG-TERM AQUATIC HAZARD - Category 2</p> <p>Eye Dam. 1, H318: SERIOUS EYE DAMAGE/ EYE IRRITATION - Category 1</p> <p>Eye Irrit. 2, H319: SERIOUS EYE DAMAGE/ EYE IRRITATION - Category 2</p> <p>Skin Corr. 1A, H314: SKIN CORROSION/IRRITATION - Category 1A</p> <p>Skin Irrit. 2, H315: SKIN CORROSION/IRRITATION - Category 2</p> <p>STOT RE 2, H373 (oral): SPECIFIC TARGET ORGAN TOXICITY (REPEATED EXPOSURE) (oral) - Category 2</p>

<b>Full text of abbreviated R-phrases:</b>	<p>R20: Harmful if inhaled.</p> <p>R22: Harmful if swallowed.</p> <p>R48/22: Harmful: danger of serious damage to health by prolonged exposure if swallowed.</p> <p>R34: Causes burns.</p> <p>R41: Risk of serious damage to eyes.</p> <p>R38: Irritating to skin.</p> <p>R36/38: Irritating to eyes and skin.</p> <p>R50: Very toxic to aquatic organisms.</p> <p>R50/53: Very toxic to aquatic organisms, may cause long-term adverse effects in the aquatic environment.</p> <p>R51/53: Toxic to aquatic organisms, may cause long-term adverse effects in the aquatic environment.</p> <p>R52/53: Harmful to aquatic organisms, may cause long-term adverse effects in the aquatic environment.</p>
<b>Full text of classifications [DSD/DPD]:</b>	<p>C: Caustic</p> <p>Xn: Harmful</p> <p>Xi: Irritant</p> <p>N: Environmental hazard</p>

#### History

<b>Issue date / Revision date:</b>	04/08/2014
<b>Date of previous issue:</b>	22/05/2013
<b>Created by:</b>	Product Stewardship

#### Notes for the reader

All reasonably practicable steps have been taken to ensure this data sheet and the health, safety and environmental information contained in it is accurate as at the date of issue specified below. No warranty or representation, express or implied, is made as to the accuracy or completeness of the data and information in this data sheet.

The data and advice given are valid if the product is sold for the application(s) specified. You should not use the product other than for the stated application or applications without seeking advice from BP Group.

It is the user's obligation to evaluate and use this product safely and to comply with all applicable laws and regulations. The BP Group accepts no responsibility for any damage or injury resulting from uses other than the stated product use of the material, from any failure to adhere to recommendations, or from hazards inherent in the nature of the material. Those purchasing the product for supply to third parties for use at work have a duty to take all necessary steps to ensure that any person handling or using the product is provided with the information on this data sheet. Employers have a duty to tell employees and others who may be affected of any hazards described in this sheet and of any precautions that should be taken. You can contact the BP Group to ensure that this document is the most current available. Alteration of this document is strictly prohibited.

## 13 KUKA Service

### 13.1 Requesting support

<b>Introduction</b>	This documentation provides information on operation and operator control, and provides assistance with troubleshooting. For further assistance, please contact your local KUKA subsidiary.
<b>Information</b>	<p><b>The following information is required for processing a support request:</b></p> <ul style="list-style-type: none"> <li>■ Description of the problem, including information about the duration and frequency of the fault</li> <li>■ As comprehensive information as possible about the hardware and software components of the overall system</li> </ul> <p>The following list gives an indication of the information which is relevant in many cases:</p> <ul style="list-style-type: none"> <li>■ Model and serial number of the kinematic system, e.g. the manipulator</li> <li>■ Model and serial number of the controller</li> <li>■ Model and serial number of the energy supply system</li> <li>■ Designation and version of the system software</li> <li>■ Designations and versions of other software components or modifications</li> <li>■ Diagnostic package <b>KrcDiag</b>: Additionally for KUKA Sunrise: Existing projects including applications For versions of KUKA System Software older than V8: Archive of the software (<b>KrcDiag</b> is not yet available here.)</li> <li>■ Application used</li> <li>■ External axes used</li> </ul>

### 13.2 KUKA Customer Support

<b>Availability</b>	KUKA Customer Support is available in many countries. Please do not hesitate to contact us if you have any questions.
<b>Argentina</b>	<p>Ruben Costantini S.A. (Agency) Luis Angel Huergo 13 20 Parque Industrial 2400 San Francisco (CBA) Argentina Tel. +54 3564 421033 Fax +54 3564 428877 ventas@costantini-sa.com</p>
<b>Australia</b>	<p>KUKA Robotics Australia Pty Ltd 45 Fennell Street Port Melbourne VIC 3207 Australia Tel. +61 3 9939 9656 info@kuka-robotics.com.au www.kuka-robotics.com.au</p>

<b>Belgium</b>	KUKA Automatisering + Robots N.V. Centrum Zuid 1031 3530 Houthalen Belgium Tel. +32 11 516160 Fax +32 11 526794 info@kuka.be www.kuka.be
<b>Brazil</b>	KUKA Roboter do Brasil Ltda. Travessa Claudio Armando, nº 171 Bloco 5 - Galpões 51/52 Bairro Assunção CEP 09861-7630 São Bernardo do Campo - SP Brazil Tel. +55 11 4942-8299 Fax +55 11 2201-7883 info@kuka-roboter.com.br www.kuka-roboter.com.br
<b>Chile</b>	Robotec S.A. (Agency) Santiago de Chile Chile Tel. +56 2 331-5951 Fax +56 2 331-5952 robotec@robotec.cl www.robotec.cl
<b>China</b>	KUKA Robotics China Co., Ltd. No. 889 Kungang Road Xiaokunshan Town Songjiang District 201614 Shanghai P. R. China Tel. +86 21 5707 2688 Fax +86 21 5707 2603 info@kuka-robotics.cn www.kuka-robotics.com
<b>Germany</b>	KUKA Roboter GmbH Zugspitzstr. 140 86165 Augsburg Germany Tel. +49 821 797-4000 Fax +49 821 797-1616 info@kuka-roboter.de www.kuka-roboter.de



**France** KUKA Automatismes + Robotique SAS  
Techvallée  
6, Avenue du Parc  
91140 Villebon S/Yvette  
France  
Tel. +33 1 6931660-0  
Fax +33 1 6931660-1  
commercial@kuka.fr  
www.kuka.fr

**India** KUKA Robotics India Pvt. Ltd.  
Office Number-7, German Centre,  
Level 12, Building No. - 9B  
DLF Cyber City Phase III  
122 002 Gurgaon  
Haryana  
India  
Tel. +91 124 4635774  
Fax +91 124 4635773  
info@kuka.in  
www.kuka.in

**Italy** KUKA Roboter Italia S.p.A.  
Via Pavia 9/a - int.6  
10098 Rivoli (TO)  
Italy  
Tel. +39 011 959-5013  
Fax +39 011 959-5141  
kuka@kuka.it  
www.kuka.it

**Japan** KUKA Robotics Japan K.K.  
YBP Technical Center  
134 Godo-cho, Hodogaya-ku  
Yokohama, Kanagawa  
240 0005  
Japan  
Tel. +81 45 744 7691  
Fax +81 45 744 7696  
info@kuka.co.jp

**Canada** KUKA Robotics Canada Ltd.  
6710 Maritz Drive - Unit 4  
Mississauga  
L5W 0A1  
Ontario  
Canada  
Tel. +1 905 670-8600  
Fax +1 905 670-8604  
info@kukarobotics.com  
www.kuka-robotics.com/canada

<b>Korea</b>	KUKA Robotics Korea Co. Ltd. RIT Center 306, Gyeonggi Technopark 1271-11 Sa 3-dong, Sangnok-gu Ansan City, Gyeonggi Do 426-901 Korea Tel. +82 31 501-1451 Fax +82 31 501-1461 info@kukakorea.com
<b>Malaysia</b>	KUKA Robot Automation (M) Sdn Bhd South East Asia Regional Office No. 7, Jalan TPP 6/6 Taman Perindustrian Puchong 47100 Puchong Selangor Malaysia Tel. +60 (03) 8063-1792 Fax +60 (03) 8060-7386 info@kuka.com.my
<b>Mexico</b>	KUKA de México S. de R.L. de C.V. Progreso #8 Col. Centro Industrial Puente de Vigas Tlalnepantla de Baz 54020 Estado de México Mexico Tel. +52 55 5203-8407 Fax +52 55 5203-8148 info@kuka.com.mx www.kuka-robotics.com/mexico
<b>Norway</b>	KUKA Sveiseanlegg + Roboter Sentrumsvegen 5 2867 Hov Norway Tel. +47 61 18 91 30 Fax +47 61 18 62 00 info@kuka.no
<b>Austria</b>	KUKA Roboter CEE GmbH Gruberstraße 2-4 4020 Linz Austria Tel. +43 7 32 78 47 52 Fax +43 7 32 79 38 80 office@kuka-roboter.at www.kuka.at

**Poland** KUKA Roboter Austria GmbH  
Spółka z ograniczoną odpowiedzialnością  
Oddział w Polsce  
Ul. Porcelanowa 10  
40-246 Katowice  
Poland  
Tel. +48 327 30 32 13 or -14  
Fax +48 327 30 32 26  
ServicePL@kuka-roboter.de

**Portugal** KUKA Sistemas de Automatización S.A.  
Rua do Alto da Guerra n° 50  
Armazém 04  
2910 011 Setúbal  
Portugal  
Tel. +351 265 729780  
Fax +351 265 729782  
kuka@mail.telepac.pt

**Russia** KUKA Robotics RUS  
Werbnaja ul. 8A  
107143 Moskau  
Russia  
Tel. +7 495 781-31-20  
Fax +7 495 781-31-19  
info@kuka-robotics.ru  
www.kuka-robotics.ru

**Sweden** KUKA Svetsanläggningar + Robotar AB  
A. Odhners gata 15  
421 30 Västra Frölunda  
Sweden  
Tel. +46 31 7266-200  
Fax +46 31 7266-201  
info@kuka.se

**Switzerland** KUKA Roboter Schweiz AG  
Industriestr. 9  
5432 Neuenhof  
Switzerland  
Tel. +41 44 74490-90  
Fax +41 44 74490-91  
info@kuka-roboter.ch  
www.kuka-roboter.ch

<b>Spain</b>	KUKA Robots IBÉRICA, S.A. Pol. Industrial Torrent de la Pastera Carrer del Bages s/n 08800 Vilanova i la Geltrú (Barcelona) Spain Tel. +34 93 8142-353 Fax +34 93 8142-950 Comercial@kuka-e.com www.kuka-e.com
<b>South Africa</b>	Jendamark Automation LTD (Agency) 76a York Road North End 6000 Port Elizabeth South Africa Tel. +27 41 391 4700 Fax +27 41 373 3869 www.jendamark.co.za
<b>Taiwan</b>	KUKA Robot Automation Taiwan Co., Ltd. No. 249 Pujong Road Jungli City, Taoyuan County 320 Taiwan, R. O. C. Tel. +886 3 4331988 Fax +886 3 4331948 info@kuka.com.tw www.kuka.com.tw
<b>Thailand</b>	KUKA Robot Automation (M)SdnBhd Thailand Office c/o Maccall System Co. Ltd. 49/9-10 Soi Kingkaew 30 Kingkaew Road Tt. Rachatheva, A. Bangpli Samutprakarn 10540 Thailand Tel. +66 2 7502737 Fax +66 2 6612355 atika@ji-net.com www.kuka-roboter.de
<b>Czech Republic</b>	KUKA Roboter Austria GmbH Organisation Tschechien und Slowakei Sezemická 2757/2 193 00 Praha Horní Počernice Czech Republic Tel. +420 22 62 12 27 2 Fax +420 22 62 12 27 0 support@kuka.cz

**Hungary** KUKA Robotics Hungaria Kft.  
Fö út 140  
2335 Taksony  
Hungary  
Tel. +36 24 501609  
Fax +36 24 477031  
info@kuka-robotics.hu

**USA** KUKA Robotics Corporation  
51870 Shelby Parkway  
Shelby Township  
48315-1787  
Michigan  
USA  
Tel. +1 866 873-5852  
Fax +1 866 329-5852  
info@kukarobotics.com  
www.kukarobotics.com

**UK** KUKA Automation + Robotics  
Hereward Rise  
Halesowen  
B62 8AN  
UK  
Tel. +44 121 585-0800  
Fax +44 121 585-0900  
sales@kuka.co.uk



## Index

### Numbers

2004/108/EC 102  
 2006/42/EC 102  
 89/336/EEC 102  
 95/16/EC 102  
 97/23/EC 102

### A

Accessories 11, 91  
 Altitude 17, 34  
 Ambient conditions 17, 34  
 Ambient temperature, operation 17, 34  
 Ambient temperature, storage 17, 34  
 Ambient temperature, transportation 17, 34  
 Angle of rotation 53  
 ANSI/RIA R.15.06-2012 103  
 Appendix 161  
 Applied norms and regulations 102  
 Automatic mode 100  
 Axes, controlled, number 16, 33  
 Axes, number 16, 33  
 Axis data, KR 10 sixx 35  
 Axis data, KR 6 sixx 18  
 Axis range 93  
 Axis range limitation 95  
 Axis range monitoring 95

### B

Basic data, KR 10 sixx 33  
 Basic data, KR 6 sixx 16  
 Brake defect 97  
 Brake release device 96  
 Braking distance 93

### C

CE mark 92  
 Ceiling-mounted robot, installation 130  
 Cleaning work 101  
 Connecting cable, standard 135  
 Connecting cables 11, 18, 34, 91, 109, 134  
 Controller 17, 34  
 Counterbalancing system 101  
 Covers A2 and A3, greasing 143  
 Customer interfaces 110

### D

Danger zone 93  
 Declaration of conformity 92  
 Declaration of incorporation 91, 92  
 Decommissioning 102, 151  
 Decommissioning, ceiling-mounted robot 155  
 Decommissioning, floor-mounted robot 151  
 Decommissioning, wall-mounted robot 152  
 Description, manipulator 12  
 Disposal 102, 151  
 Documentation, industrial robot 7

### E

EC declaration of conformity 92  
 Electromagnetic compatibility (EMC) 103  
 EMC Directive 92, 102  
 EN 60204-1 + A1 103  
 EN 61000-6-2 103  
 EN 61000-6-4 + A1 103  
 EN 614-1 + A1 103  
 EN ISO 10218-1 103  
 EN ISO 12100 103  
 EN ISO 13849-1 102  
 EN ISO 13849-2 102  
 EN ISO 13850 102  
 Extension 53  
 External axes 91, 93

### F

Faults 98  
 Flexolub-A1, lubricant 161  
 Floor-mounted robot, installation 125  
 Footprint 17, 34  
 Foundation data, KR 10 sixx 49  
 Foundation data, KR 6 sixx 31  
 Function test 99

### G

General information 52  
 General safety measures 97

### H

Handling equipment 120  
 Hazardous substances 102

### I

Industrial robot 91  
 Intended use 92  
 Interface A1 110  
 Interfaces 109  
 Introduction 7  
 ISO 9283, repeatability 16, 33

### K

KCP 93, 97  
 KCP, KUKA Control Panel 53  
 Keyboard, external 97  
 KL 7  
 KUKA Customer Support 183  
 KUKA smartPAD 93

### L

Labeling 96  
 Liability 91  
 Linear unit 91  
 Low Voltage Directive 92  
 Lubricants 141  
 Lubrication work 141

**M**

Machine data 99  
 Machine frame mounting 107  
 Machine frame mounting, installation 124  
 Machinery Directive 92, 102  
 main axes 52  
 Maintenance 100, 141  
 Maintenance intervals 141  
 Maintenance symbols 141  
 Maintenance table 141  
 Manipulator 11, 91, 93  
 Manual mode 99  
 Material designation 159  
 Mechanical axis range limitation 95  
 Mechanical end stops 95  
 MEMD 7  
 Mounting base 105  
 Mounting base, installation 123  
 Mounting position 17, 34  
 Mouse, external 97  
 Moving the robot, without drive energy 140

**O**

OBEEN FS 2, lubricant 165  
 Operator 93, 94  
 Options 11, 91  
 Overload 97  
 Overview of the robot system 11

**P**

Payload diagram 26, 43  
 Payloads, KR 10 sixx 43  
 Payloads, KR 6 sixx 26  
 Permissible angle of inclination 17, 34  
 Personnel 93  
 Planning 105  
 Plant integrator 93  
 Plates and labels 51  
 Positioner 91  
 Pressure Equipment Directive 101, 102  
 Preventive maintenance work 101  
 Principal dynamic loads 17, 33  
 Product description 11  
 Program override, motion velocity 53  
 Protection rating, in-line wrist 17, 33  
 Protection rating, robot 17, 33  
 Protective equipment, overview 95  
 Purpose 9

**R**

RDC 8  
 Reaction distance 93  
 Recommissioning 98, 123  
 Reference point 17, 33  
 Relative air humidity 17, 34  
 Release device 96  
 Repair 100, 147  
 Repeatability 16, 33  
 Robot controller 11, 91  
 Robot, cleaning 145

**S**

Safety 91  
 Safety data sheet, Flexolub-A1 lubricant 161  
 Safety data sheet, OBEEN FS 2 lubricant 165  
 Safety data sheets 161  
 Safety instructions 7  
 Safety of machinery 102, 103  
 Safety zone 93, 94  
 Safety, general 91  
 Service life 93  
 Service, KUKA Roboter 183  
 smartPAD 8, 11, 93, 97  
 Software 11, 91  
 Sound level 17, 33  
 Standard colors 17, 34  
 Start-up 98, 123  
 STOP 0 53, 93  
 STOP 1 53, 93  
 STOP 2 93  
 Stop category 0 93  
 Stop category 1 93  
 Stop category 2 93  
 Stop signal 52  
 Stopping distance 52, 93  
 Stopping distances 52  
 Stopping distances, KR 10 R1100 sixx 77  
 Stopping distances, KR 10 R1100 sixx C 77  
 Stopping distances, KR 10 R1100 sixx W 83  
 Stopping distances, KR 10 R900 sixx 77  
 Stopping distances, KR 10 R900 sixx C 77  
 Stopping distances, KR 10 R900 sixx W 83  
 Stopping distances, KR 6 R700 sixx 54  
 Stopping distances, KR 6 R700 sixx C 54  
 Stopping distances, KR 6 R700 sixx W 59  
 Stopping distances, KR 6 R900 sixx 65  
 Stopping distances, KR 6 R900 sixx C 65  
 Stopping distances, KR 6 R900 sixx W 71  
 Stopping time 52  
 Stopping times 52  
 Stopping times, KR 10 R1100 sixx 77  
 Stopping times, KR 10 R1100 sixx C 77  
 Stopping times, KR 10 R1100 sixx W 83  
 Stopping times, KR 10 R900 sixx 77  
 Stopping times, KR 10 R900 sixx C 77  
 Stopping times, KR 10 R900 sixx W 83  
 Stopping times, KR 6 R700 sixx 54  
 Stopping times, KR 6 R700 sixx C 54  
 Stopping times, KR 6 R700 sixx W 59  
 Stopping times, KR 6 R900 sixx 65  
 Stopping times, KR 6 R900 sixx C 65  
 Stopping times, KR 6 R900 sixx W 71  
 Storage 102, 151  
 Support request 183  
 System integrator 92, 93, 94

**T**

T1 93  
 T2 93  
 Teach pendant 11, 91  
 Technical data 15  
 Terms used 7, 53



Terms used, safety 93  
Tightening torques 161  
Toothed belt tension A5, A6, adjusting 147  
Toothed belt tension A5, A6, measuring 147  
Toothed belts A5 and A6, installation 144  
Toothed belts A5 and A6, removal 144  
Training 9  
Transformation name 17, 34  
Transport position 117  
Transportation 98, 117  
Turn-tilt table 91

## **U**

Use, contrary to intended use 91  
Use, improper 91  
User 93, 94  
Users 9

## **V**

Volume of working envelope 16, 33

## **W**

Wall-mounted robot, installation 126  
Warnings 7  
Weight 17, 33  
Working envelope 19, 35  
Working range limitation 95  
Workspace 93, 94



